

CoriolisMaster FCB430, FCB450, FCH430, FCH450 Coriolis mass flowmeter

High precision measurement of mass and volume flow, density, temperature and concentration with just one device

Measurement made easy



Up to five modular I/Os

- Multivariable meter design
- Optional plug-in cards
- Automatic firmware update

SmartSensor

- All digital solution
- Installation flexibility
- Meter intelligence located in the sensor

SensorApplicationMemory

- Maximum data security
- Plug and play electronics replacement

ABB common look and feel

- Easy Set-up
- Operation through the glass via capacitive keys

VeriMass on-board verification and diagnostics

- Online preventive maintenance
- Extended maintenance cycles
- Reduced maintenance effort

CoriolisMaster software tools

- DensiMass for concentration measurement, net-mass and volume flow calculations
- FillMass for filling applications

Designed for 70 °C (158 °F) ambient temperature and high vibrations

Lower pressure drop

Self-draining

Global approvals for explosion protection

CoriolisMaster FCH400

- Designed for hygienic applications
- EHEDG certified

CoriolisMaster FCB430, FCB450, FCH430, FCH450

Coriolis mass flowmeter

Overview – models

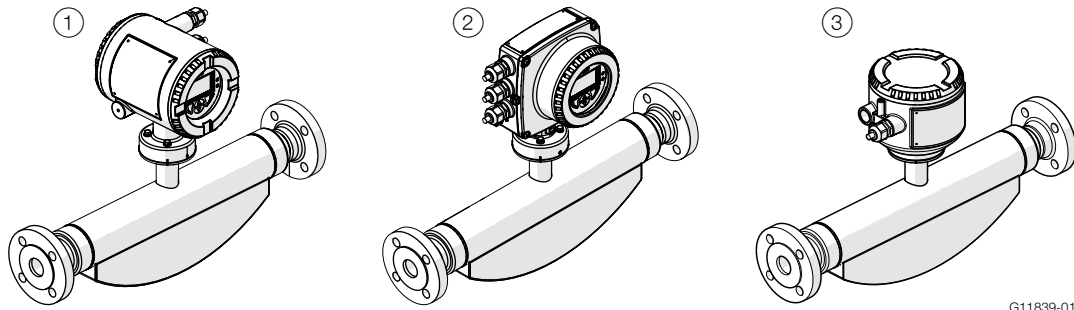

G11839-01

Fig. 1: Designs

① Sensor (integral mount design, dual-compartment housing) ② Sensor (integral mount design, single-compartment housing) ③ Sensor (remote mount design)

Sensor				
Model	FCB400 standard design		FCH400 hygienic design	
Housing	Integral mount design, remote mount design			
Measuring accuracy for liquids	FCB430	FCB450	FCH430	FCH450
Mass flow ¹⁾	0.4 %, 0.25 % and 0.2 %	0.1 % and 0.15 %	0.4 %, 0.25 % and 0.2 %	0.1 % and 0.15 %
Volume flow ¹⁾	0.4 %, 0.25 % and 0.2 %	0.15 %	0.4 %, 0.25 % and 0.2 %	0.15 %
Density	0.01 kg/l	– 0.002 kg/l – 0.001 kg/l (optional) – 0.0005 kg/l ²⁾	0.01 kg/l	– 0.002 kg/l – 0.001 kg/l (optional) – 0.0005 kg/l ²⁾
Temperature	1 K	0,5 K	1 K	0,5 K
Measuring accuracy for gases¹⁾	1 %	0,5 %	1 %	0,5 %
Approved measuring medium temperature T_{medium}	-50 ... 160 °C (-58 ... 320 °F)	-50 ... 205 °C (-58 ... 400 °F)	-50 ... 160 °C (-58 ... 320 °F)	-50 ... 205 °C (-58 ... 400 °F)
Process connection				
Flange DIN 2501 / EN 1092-1	DN 10 ... 200, PN 40 ... 100		–	
Flange ASME B16.5	DN 1/4" ... 8" PN CL150 ... CL600		–	
Pipe fitting DIN 11851	DN 10 ... 100 (1/4 ... 4")		DN 15 ... 80 (1/2 ... 3")	
Tri-clamp DIN 32676 (ISO 2852), Tri-clamp BPE	DN 10 ... 100 (1/4 ... 4")		DN 10 ... 100 (1/4 ... 4")	
Other connections	On request		On request	
Wetted material	Stainless steel 1.4435 or 1.4404 (AISI 316L), nickel-alloy C4 / C22 (optional)		Stainless steel, polished 1.4404 (AISI 316L) or 1.4435 (AISI 316L)	
IP rating	– Integral mount design: IP 65 / IP 67, NEMA 4X – Remote mount design: IP 65 / IP 67 / IP 68 (sensor only, immersion depth: 5 m), NEMA 4X			

Approvals

– Explosion protection ATEX / IECEx	
– Explosion protection cFMus	
– Hygiene approvals	– EHEDG, FDA compliant
– Further approvals	At www.abb.com/flow or on request.

1) Indication of accuracy in % of the measured value (% of measured value)

2) Measuring accuracy following on-site calibration under operating conditions

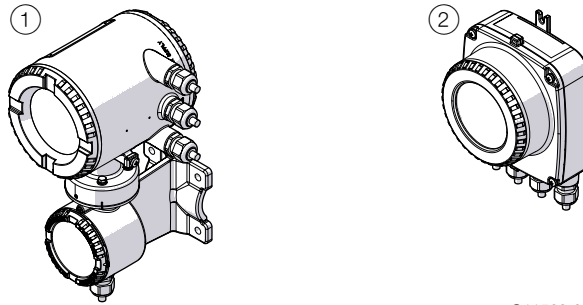

G11566-01

Fig. 2: Transmitter with remote mount design

① Dual-compartment housing ② Single-compartment housing

Transmitter	
Housing	Integral mount design (see Fig. 1, pos. ① and ②), remote mount design.
IP rating	IP 65 / IP 67, NEMA 4X
Cable length	Maximum 200 m (656 ft), remote mount design only
Power supply	100 ... 240 V AC, 50 / 60 Hz 11 ... 30 V DC
Outputs in basic version	Current output: 4 ... 20 mA, active or passive Digital output 1: passive, configurable as pulse, frequency or switch output Digital output 2: passive, configurable as pulse or switch output
Additional optional outputs	The transmitter has two slots in which plug-in cards can be inserted to provide additional inputs and outputs. The following expansion cards are available: <ul style="list-style-type: none"> – Current output (maximum two expansion cards simultaneously) – Digital output (maximum one expansion card) – Digital input (maximum one expansion card) – 24 V DC power supply for active outputs (maximum one expansion card)
External output zero return	Yes
External totalizer reset	Yes
Forward / reverse flow metering	Yes
Counter	Yes
Communication	HART protocol 7.1
Empty pipe detection	Yes, via configurable density alarm
Self-monitoring and diagnosis	Yes
Local display	Yes
Field optimization for flow and density	Yes
Concentration measurement "DensiMass"	Yes, optional on models FCB450 and FCH450
"FillMass" fill function	Yes, optional on models FCB450 and FCH450
"VeriMass" function	Yes, optional

CoriolisMaster FCB430, FCB450, FCH430, FCH450

Coriolis mass flowmeter

General data

Device description

The CoriolisMaster FCB430, FCB450, FCH430, FCH450 is the cost-effective and uncomplicated ABB mass flowmeter with a new modular transmitter.

The CoriolisMaster FCB430, FCB450, FCH430, FCH450 operates in accordance with the Coriolis principle. The design offers the following benefits:

- Space-saving, robust design.
- Variety of process connections.
- Modular, flexible output concept.

Transmitter with digital signal processor (DSP)

The transmitter for the CoriolisMaster FCB430, FCB450, FCH430, FCH450 incorporates a digital signal processor (DSP) that enables high-precision mass flow and density measurements to be taken. The Coriolis sensor signals are immediately converted into digital data without any intermediate analog steps.

Excellent long-term stability and reliability together with fast signal processing are achieved with the new DSP transmitter.

Self-diagnostic functions for the flowmeter sensor and the transmitter, in combination with absolute zero stability, are benefits you can count on to ensure accurate measurements are taken.

The CoriolisMaster FCB430, FCB450, FCH430, FCH450 transmitter is particularly well suited for use in the following cases:

- Whenever mass flowrate is to be metered with maximum accuracy
- Whenever the density of the medium being measured is being determined
- Whenever the components of a recipe being mixed
- When metering non-conductive media or highly viscous, solid-loaded liquids, for example
- In batch filling processes

SIL - functional safety

Term	Value
DeviceType	CoriolisMaster FCB430, FCB450, FCH430, FCH450 with option "CS"
Type of Assessment	Verification in accordance with IEC 61508 2, route 1S/1H
SIL capability	SIL2 (Low demand mode)
HFT	0
Component Type	B

Failure Rates	Design	
	Integral mount design	Remote mount design
SFF	93.3 %	93.2 %
PFD _{AVG} after 1 year (MTTR 48 hours)	6,91E-04	7,28E-04
PFD _{AVG} after 2 years (MTTR 48 hours)	1,31E-03	1,38E-03
PFD _{AVG} after 4 years (MTTR 48 hours)	2,54E-03	2,68E-03
λ_S	435 FIT	435 FIT
λ_{Dd}	1529 FIT	1616 FIT
λ_{Du}	142 FIT	149 FIT

SAFETY INSTRUCTIONS

The listed failure rates λ_S , λ_{Dd} , λ_{Du} and PFD_{AVG} relate to the failure rates of the Siemens norm SN29500 at an average component temperature of 40 °C (104 °F).

This corresponds to an average ambient temperature of 30 °C (86 °F).

FillMass batch function
Only for FCB450 / FCH450

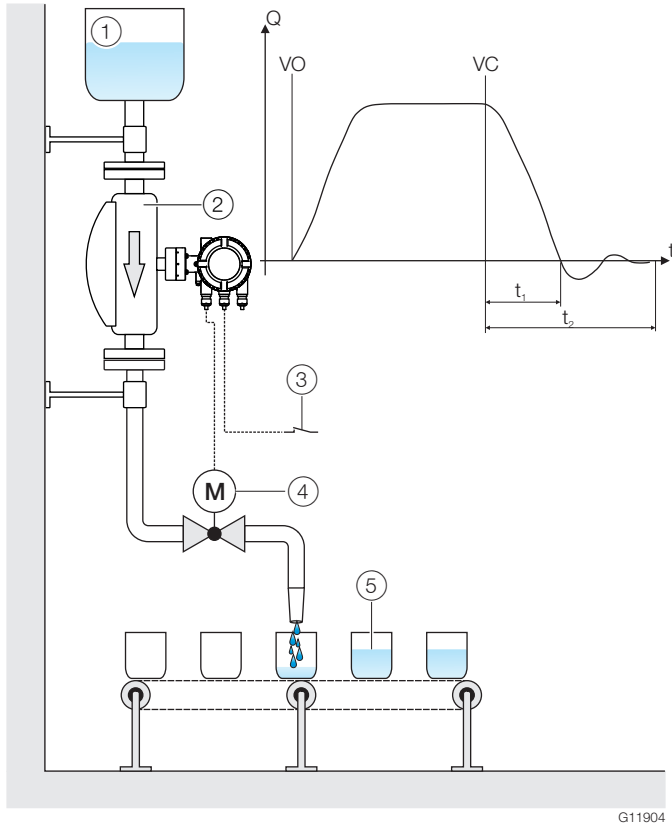

Fig. 3: FillMass fill function
 ① Collection tank ② Sensor ③ Fill start / stop (digital input via plug-in card) ④ Fill valve ⑤ Fill container

Diagram key	
VO	Valve open (filling started)
VC	Valve closed (fill quantity reached)
t_1	Valve closing time
t_2	Overrun time

The integrated FillMass fill function allows filling processes to be recorded in > 3 seconds.

For this purpose, the filling quantity is given via an adjustable totalizer.

The fill function is controlled via the HART interface or via the digital input.

The valve is triggered via one of the digital outputs and closed again once the preset filling quantity is reached.

The transmitter measures the overrun quantity and calculates the overrun correction from this.

Additionally, the low flow cut-off can be activated if required.

DensiMass concentration measurement

Only for FCB450 / FCH450

The transmitter can calculate the current concentration from the measured density and temperature using concentration matrices.

The following concentration matrices are preconfigured in the transmitter as standard:

- Concentration of sodium hydroxide in water
- Concentration of alcohol in water
- Concentration of sugar in water
- Concentration of maize starch in water
- Concentration of wheat starch in water

The user can enter two more user-defined matrices containing up to 100 values.

Calculating standard volumes and standard densities of liquids

If a suitable matrix is available, the DensiMass function also allows the measured volume to be corrected for any selected temperature.

The measured density can also be corrected for a given temperature.

However, this is only possible when measuring liquids and after entering an appropriate matrix.

This correction can also be performed using the default matrices (see above).

The calculated standard volumes and standard densities can also be issued for all other process variables.

The software "DensiMatrix" is available for the easy input of the matrix.

CoriolisMaster FCB430, FCB450, FCH430, FCH450

Coriolis mass flowmeter

Accuracy of the concentration measurement

The accuracy of the concentration measurement is determined in the first instance by the quality of the matrix data entered.

However, as the calculation is based on temperature and density (the input variables), the accuracy of the concentration measurement is ultimately determined by the measuring accuracy of the temperature and the density.

Example:

Density of 0 % alcohol in water at 20 °C (68 °F): 998.23 g/l

Density of 100 % alcohol in water at 20 °C (68 °F): 789.30 g/l

Concentration	Density
100 %	208.93 g/l
0.48 %	1 g/l
0.96 %	2 g/l

Thus, the accuracy class of the density measurement directly determines the accuracy of the concentration measurement.

VeriMass erosion monitor

The integrated VeriMass diagnosis function allows the status of the meter tube to be monitored. This enables changes due to material erosion and the formation of deposits on the meter tube walls to be identified at an early stage.

If the set limit value is exceeded, an alarm is triggered, e.g. via the programmable digital output or HART, depending on the configuration.

The limit value for the erosion monitor can be set either automatically or manually.

Automatic adjustment

The transmitter monitors the sensor's driver current over a prolonged period and creates a "fingerprint" for the relevant application. The transmitter generates a corresponding tolerance value for deviations in the driver current.

The transmitter compares the behavior of the driver current with the generated fingerprint and triggers the relevant error message in the event of prolonged deviations.

Manual adjustment

For applications where automatic adjustment of the erosion monitor does not provide a satisfactory result, the erosion monitor can be balanced manually.

For more information please contact ABB Service or the sales organization.

Flowmeter sensor

General installation conditions

Installation location and assembly

Note the following points when selecting the installation location and when mounting the sensor:

- The ambient conditions (IP rating, ambient temperature range T_{amb}) of the device must be adhered to at the installation location.
- Sensors and transmitters must not be exposed to direct sunlight. If necessary, provide a suitable means of sun protection on site. The limit values for the ambient temperature T_{amb} must be observed.
- On flange devices, ensure that the counterflanges of the piping are aligned plane parallel. Only install flange devices with suitable gaskets.
- Prevent the sensor from coming into contact with other objects.
- The device is designed for industrial applications. No special EMC protective measures are required if the electromagnetic fields and interference at the installation location of the device comply with "Best Practice" guidelines (in accordance with the standards referred to in the declaration of conformity).
Maintain a suitable distance from electromagnetic fields and interference that extend beyond the usual dimensions.

Gaskets

Users are responsible for selecting and mounting suitable gaskets (material, shape).

Note the following points when selecting and mounting gaskets:

- Only gaskets made from a material that is compatible with the measuring medium and measuring medium temperature may be used
- Gaskets must not extend into the flow area, since possible turbulence may influence the accuracy of the device.

Calculating pressure loss

Pressure loss is determined by the properties of the medium and the flow.

Documents to help with the calculation of pressure loss can be accessed from www.abb.com/flow-selector.

Brackets and supports

No special supports or damping are required for the device when the device is used and installed as intended.

In systems designed in accordance with "Best Practice" guidelines, the forces acting on the device are already sufficiently absorbed. This is also true of devices installed in series or in parallel.

For heavier devices, it is advisable to use additional supports / brackets on site. Doing this prevents damage to the process connections and piping from lateral forces.

Please observe the following points:

- Mount two supports or brackets symmetrically in the immediate vicinity of the process connections.
- Do not attach any supports or brackets to the flowmeter sensor housing.

Inlet section

The sensor does not require any inlet section.

The devices can be installed directly before/after manifolds, valves or other equipment, provided that no cavitation is caused by this equipment.

Mounting position

The flowmeter operates in any mounting position.

Depending on the measuring medium (liquid or gas) and the measuring medium temperature, certain mounting positions are preferable to others. For this purpose, consider the following examples.

The preferred flow direction is indicated by the arrow on the sensor. The flow will be displayed as positive.

The specified measuring accuracy can be achieved only in the calibrated flow direction (for forward flow calibration, this is only in the direction of the arrow; for the optional forward flow and reverse flow calibration, this can be in both flow directions).

CoriolisMaster FCB430, FCB450, FCH430, FCH450

Coriolis mass flowmeter

Liquid measuring media

Observe the following points to avoid measuring errors:

- The meter tubes must always be completely filled with the measuring medium.
- The gases dissolved in the measuring medium must not leak out. To safeguard this, a minimum back pressure of 0.2 bar (2.9 psi) is recommended.
- The minimum vapor pressure of the measuring medium must be maintained when there is negative pressure in the meter tube or when liquids are gently simmering.
- During operation, there must be no phase transitions in the measuring medium.

Vertical installation

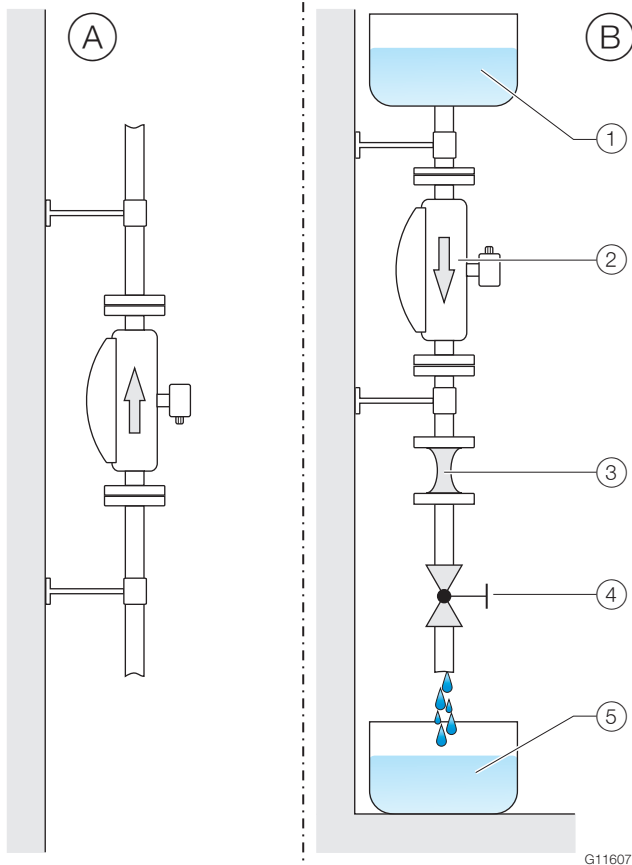

Fig. 4: Vertical installation

- ① Storage tank ② Sensor ③ Pipe contraction / orifice plate
④ Isolating device ⑤ Fill container

(A) Vertical installation in riser

For vertical installation in a riser, no special measures are required.

(B) Vertical installation in a drop line

For vertical installation in a downpipe, a piping constriction or an orifice plate must be installed below the sensor. Doing this prevents the sensor from draining during the measurement.

Horizontal installation

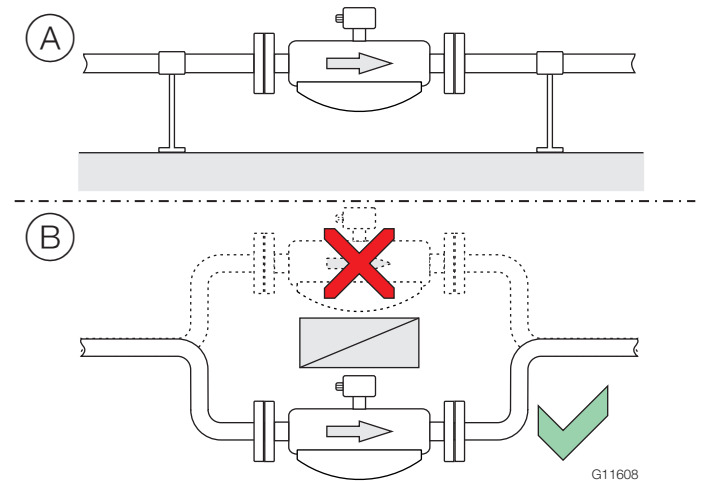

Fig. 5 Horizontal installation

- (A) For liquid measuring media and horizontal installation, the transmitter and terminal box must point upward.
(B) Installing the sensor at the highest point of the piping leads to an increased number of measuring errors due to the accumulation of air or the formation of gas bubbles in the meter tube.

Gaseous measuring media

Observe the following points to avoid measuring errors:

- Gases must be dry and free of liquids and condensates.
- Avoid the accumulation of liquids and the formation of condensate in the meter tube.
- During operation, there must be no phase transitions in the measuring medium.

If there is a risk of condensate formation when using gaseous measuring media, note the following:

Ensure that condensates cannot accumulate in front of the sensor.

If this cannot be avoided, we recommend that the sensor is installed vertically with a downward flow direction.

Vertical installation

For vertical installation, no special measures are required.

Horizontal installation

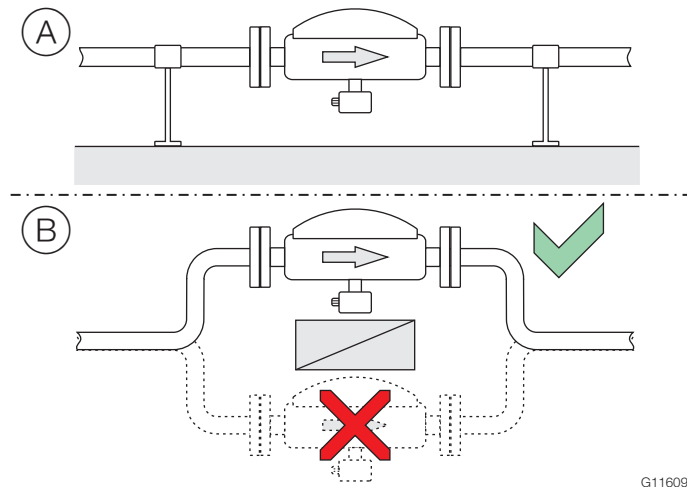

Fig. 6 Horizontal installation

- (A) For gaseous measuring media and horizontal installation, the transmitter and terminal box must point downward.
- (B) Installing the sensor at the lowest point of the piping leads to an increased number of measuring errors due to the accumulation of liquid or the formation of condensates in the meter tube.

Sensor insulation

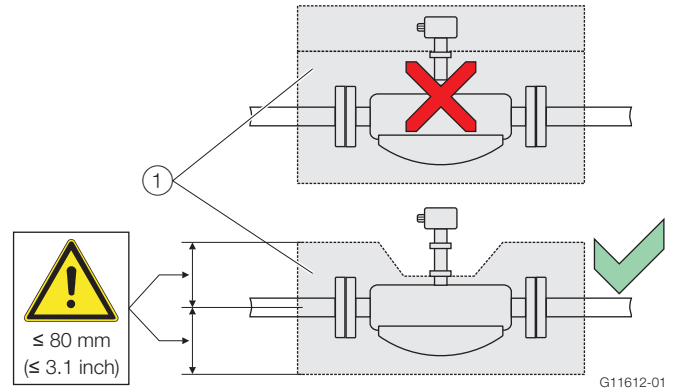

Fig. 7: Installation when T_{medium} is $-50^{\circ}\dots 205^{\circ}\text{C}$ ($-58 \dots 400^{\circ}\text{F}$)

① Insulation

The sensor may be insulated only in conjunction with option TE1 "Tower length extension - meter insulation capability" or TE2 "Tower length extension - meter insulation capability with double sealing", as shown in Fig. 7.

CoriolisMaster FCB430, FCB450, FCH430, FCH450

Coriolis mass flowmeter

Turn-off devices for zero point adjustment

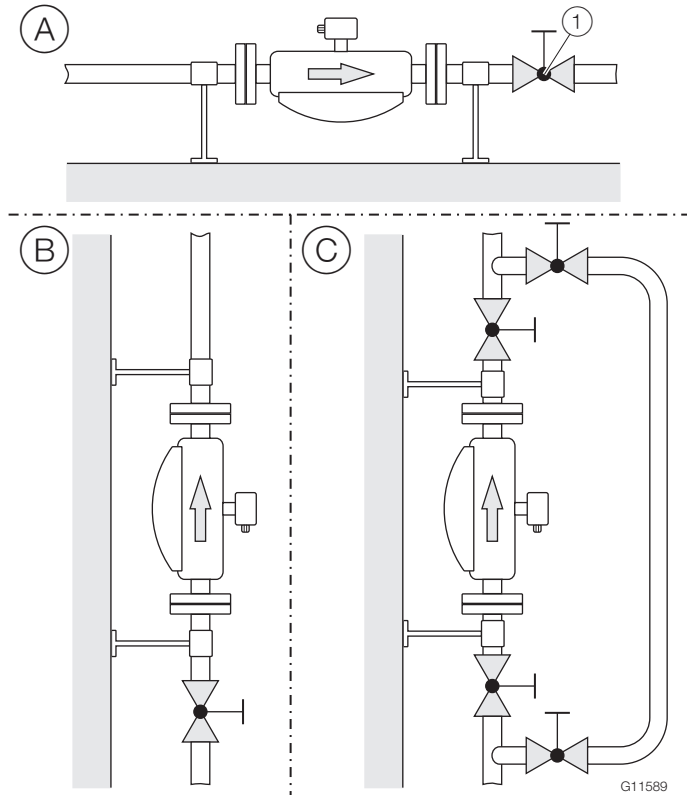

Fig. 8: Mounting options for turn-off devices (example)

① Turn-off device

To guarantee the conditions for zero point adjustment under operating conditions, turn-off devices are required in the piping:

- Ⓐ At least on the outlet side when the transmitter is mounted in horizontal position.
- Ⓑ At least on the inlet side when the transmitter is mounted in vertical position.
- Ⓒ In order to perform adjustment during an ongoing process, it is advisable to mount a bypass pipe as shown.

Installation in EHEDG-compliant installations

⚠ WARNING

Risk of poisoning!

Bacteria and chemical substances can contaminate or pollute pipeline systems and the materials they are made of. In EHEDG-compliant installations, the instructions below must be observed.

- The required self-draining functionality of the sensor can only be guaranteed when the vertical mounting position is used (see also Fig. 4 on page 8).
- The combination of process connections and gaskets selected by the operator may comprise only EHEDG-compliant components. Note the information in the current version of the EHEDG Position Paper entitled "Hygienic Process connections to use with hygienic components and equipment".
- The pipe fitting in accordance with DIN 11851 is approved for use in conjunction with an EHEDG-compliant gasket.

Designs

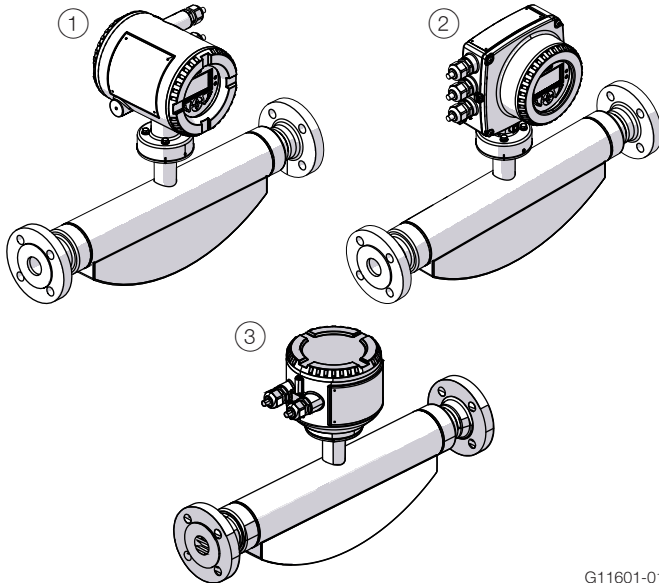

Fig. 9: Sensor FCB4xx / FCH4xx

- ① Integral mount design with dual-compartment transmitter housing
 ② Integral mount design with single-compartment transmitter housing
 ③ Remote mount design (without transmitter)

G11601-01

Measuring accuracy Reference conditions

Calibration fluid	Water — Temperature: 25 °C (77 °F) ±5 K — Pressure: 2 ... 4 bar (29 ... 58 psi)
Ambient temperature	25 °C (77 °F) +10 K / -5 K
Power supply	Line voltage according to name plate $U_N \pm 1\%$
Warm-up phase	30 minutes
Installation	— Installation according to chapter titled "Installation instructions" and "Mounting positions" — No visible gas phase — No external mechanical or hydraulic disturbances, particularly cavitation
Output calibration	Pulse output

Nominal diameter and measuring range

Nominal diameter	Q_{max} in kg/h (lb/h)
DN 15 (1/2")	0 ... 8,000 (0 ... 17,637)
DN 25 (1")	0 ... 35,000 (0 ... 77,162)
DN 50 (2")	0 ... 90,000 (0 ... 198,416)
DN 80 (3")	0 ... 250,000 (0 ... 551,156)
DN 100 (4")	0 ... 520,000 (0 ... 1,146,404)
DN 150 (6")	0 ... 860,000 (0 ... 1,895,975)

Recommended flow range

Fluids:

- The recommended flow range is 5 ... 100 % of Q_{max} .
- Flows < 1 % of Q_{max} should be avoided.

Gases:

- The flow velocity of gases in the meter tube should not exceed 0.3 Mach (approx. 100 m/s (328 ft/s)).
- Flow velocities above 80m/s may lead to increased repeatability values.
- The maximum flow range of gases is determined by the operating density. Dimensioning guidelines are available at www.abb.com/flow.

CoriolisMaster FCB430, FCB450, FCH430, FCH450

Coriolis mass flowmeter

Measured error and repeatability

The measured error and repeatability are calculated as follows for the flow:

Scenario 1:

If

$$\text{Flow rate} \geq \frac{\text{Zero stability}}{(\text{base accuracy} / 100)}$$

Then:

- Maximum measured value error:
± base accuracy as % of measured value
- Repeatability:
± 1/2 x base accuracy as % of measured value

Scenario 2:

If

$$\text{Flow rate} < \frac{\text{Zero stability}}{(\text{base accuracy} / 100)}$$

Then:

- Maximum measured error
± (zero [point] stability / measured value) x 100 % of measured value
- Repeatability:
± 1/2 x (zero stability / measured value) x 100% of measured value

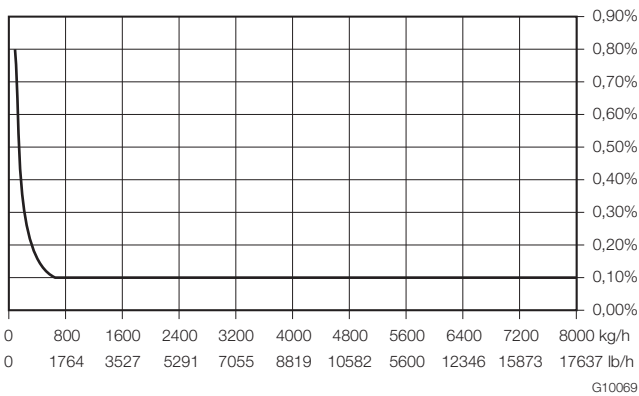

Fig. 10: Measured error FCB450 DN 15 (Example)

Measurement dynamic	Flow rate	Measured value error	Reproducibility
100:1	80 kg/h (176,4 lb/h)	≤ 0.8 % of measured value	0.4 % of measured value
50:1	160 kg/h (352,7 lb/h)	≤ 0.4 % of measured value	0.2 % of measured value
10:1	800 kg/h (1763,7 lb/h)	≤ 0.1 % of measured value	0.05 % of measured value
2:1	4000 kg/h (8818,5 lb/h)	≤ 0.1 % of measured value	0.05 % of measured value
1:1	8000 kg/h (17637 lb/h)	≤ 0.1 % of measured value	0.05 % of measured value

Measured error and base accuracy for liquids

	FCx430	FCx450
Mass flow	± 0.4 % of measured value ± 0.25 % of measured value ± 0.2 % of measured value	± 0.15 % of measured value ± 0.1 % of measured value
Volume flow	± 0.4 % of measured value ± 0.25 % of measured value ± 0.2 % of measured value	± 0.15 % of measured value
Density	0.010 kg/l ¹⁾	0.002 kg/l ¹⁾ 0.001 kg/l ²⁾ 0.0005 kg/l (option) ³⁾
Repeatability for flow rate	See chapter "Measured error and repeatability" on page 12.	
Repeatability for density	0.002 kg/l	0.002 kg/l ¹⁾ 0.001 kg/l ²⁾ 0.00025 kg/l (option) ³⁾
Temperature	1 K	0.5 K

1) For the density range from 0.5 ... 1.8 kg/dm³

2) As 1 and for the medium temperature range from -10 ... 50 °C (14 ... 122 °F)

3) As 2 and after field adjustment under operating conditions

Measured error and base accuracy for gases

	FCx430	FCx450
Mass flow	± 1 % of measured value	± 0.5 % of measured value
Temperature	1 K	0.5 K

Zero stability

Nominal diameter	kg/h (lb/h)
DN 15 (1/2")	0,64 (1,41)
DN 25 (1")	2,16 (4,76)
DN 50 (2")	7,20 (15,87)
DN 80 (3")	20 (44)
DN 100 (4")	41,6 (91,7)
DN 150 (6")	68,8 (151,68)

Effect of the medium temperature

For the flow, less than $\pm 0.0015\%$ of $Q_{max} / 1\text{ K}$.

For the density, less than $0.0001\text{ kg/dm}^3 / 1\text{ K}$.

Effect of the operating pressure

Nominal diameter	Flow rate [% of measured value / bar]	Density [kg/dm ³ / bar]
DN 15 (1/2")	-0,002	No effect
DN 25 (1")	-0,013	0,00035
DN 50 (2")	-0,010	0,00027
DN 80 (3")	-0,006	0,00019
DN 100 (4")	-0,009	0,00024
DN 150 (6")	-0,035	0,00045

Specifications

Pressure loss

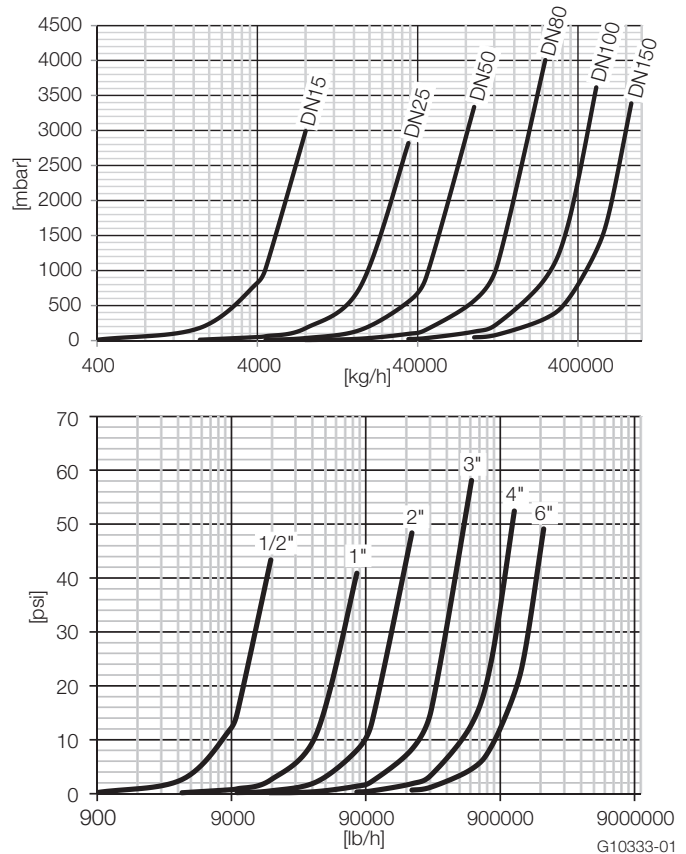

Fig. 11: Pressure loss curve (measured with water, viscosity: 1 mPas)

Viscosity range

If you are working with dynamic viscosities

$\geq 1\text{ Pas}$ (1000 mPas = 1000 cP), please contact ABB.

CoriolisMaster FCB430, FCB450, FCH430, FCH450

Coriolis mass flowmeter

Temperature limits °C (°F)

NOTICE

When using the device in potentially explosive atmospheres, note the additional temperature information in the chapters entitled "Temperature data" on page 71 and .

Temperature range of the medium being measured

- FCx430: -50 ... 160 °C (-58 ... 320 °F)
- FCx450: -50 ... 205 °C (-58 ... 401 °F)

Ambient temperature range

- Standard: -20 ... 70 °C (-4 ... 158 °F)
- Optional: -40 ... 70 °C (-40 ... 158 °F)

Process connections

For an overview of the available process connection variants, see the chapter entitled "Overview – models" on page 2.

Pressure rating

The maximum permissible operating pressure is determined by the respective process connection, the temperature of the medium to be measured, the screws, and the gasket material. For an overview of the available pressure ratings, see the chapter entitled "Overview – models" on page 2.

Enclosure as protective device (optional)

Oder Code PR5

- Maximum burst pressure 60 bar (870 psi).

Optional Oder Code PR6 and PR7 on request

- Increased burst pressures up to 100 bar (1450 psi), possible for nominal diameters DN 15 ... 100 (1/2" ... 4").
- Increased burst pressures up to 150 bar (2175 psi), possible for nominal diameters DN 15 ... 80 (1/2" ... 3").
- Flushing connections are available on request.

Pressure Equipment Directive

Conformity assessment according to Category III, fluid group 1, gas

Note the corrosion resistance of the meter tube materials in relation to the measuring medium.

Installation lengths in accordance with NAMUR standards

The CoriolisMaster FCB430, FCB450, FCH430, FCH450 is the ideal device for use in accordance with NAMUR standards.

While also conforming to other standards, the device can be ordered with installation lengths in accordance with NAMUR standards.

The exact lengths can be found in the tables in the chapter entitled "Devices DN 15 ... 150 in NAMUR standard installation lengths" on page 26 (for integral mount design) and "Devices DN 15 ... 150 in NAMUR standard installation lengths" on page 39 (for remote mount design).

Meter tube inside diameter

Inner diameters of the meter tubes of Coriolis mass flowmeter CoriolisMaster FCB430, FCB450, FCH430, FCH450.

Nominal diameter	Inner diameter of the meter tube
DN 15 (1/2")	2 x 8 mm (2 x 0,31 inch)
DN 25 (1")	2 x 16 mm (2 x 0,63 inch)
DN 50 (2")	2 x 23,7 mm (2 x 0,93 inch)
DN 80 (3")	2 x 36,62 mm (2 x 1,44 inch)
DN 100 (4")	2 x 52,51 mm (2 x 2,07 inch)
DN 150 (6")	2 x 68,9 mm (2 x 2,71 inch)

IP rating

In accordance with EN 60529: IP 65 / IP 67, NEMA 4X

NOTICE

The sensor in the remote mount design is available as an option with the IP 68 IP rating (immersion depth: up to 5 m).

Materials for the transmitter terminal box

Integral mount design	
Material	Cast aluminum or stainless steel 1.4409 (ASTM CF3M)
Paint	Paint coat $\geq 80 \mu\text{m}$ thick, RAL 9002 (gray white)
Cable gland ²⁾	Polyamide or stainless steel ¹⁾
Remote mount design	
Material	Cast aluminum
Paint	Mid-section: Paint coat $\geq 80 \mu\text{m}$ thick, RAL 7012 (basalt gray) Front cover / rear cover: RAL 9002 (gray white)
Cable gland ²⁾	Polyamide

- 1) On explosion-proof design for ambient temperature of $-40 \text{ }^\circ\text{C}$ ($-40 \text{ }^\circ\text{F}$)
- 2) Cable gland with M20 x 1.5 or NPT thread, to be selected via the order number

Materials for the sensor

Wetted components	
FCB400	FCH400
Stainless steel 1.4435 or 1.4404 (AISI 316L)	Stainless steel 1.4435 or 1.4404 (AISI 316L)
C4 ¹⁾ (2.4610) nickel alloy or C22 ¹⁾ (2.4602) nickel alloy	—
Optional: Manufacture in accordance with NACE MR0175 and MR0103 (ISO 15156)	

Housing²⁾

Stainless steel 1.4404 (AISI 316L), 1.4301 (AISI 304), 1.4308 (ASTM CF8)

- 1) Hastelloy C is a registered trademark of Haynes International. C4 and C22 nickel alloys are equivalent to Hastelloy C4 and Hastelloy C22.
- 2) If wetted parts of the sensor are made from nickel alloy, the sensor housing is made from the same material.

Material load for process connections

The temperature class of the analyzer is T4.	Nominal diameter	PS _{max}	TS _{max}	TS _{min}
Pipe fitting (DIN 11851)	DN 15 ... 40 (1/2 ... 1 1/2")	40 bar (580 psi)	140 °C (284 °F)	-40 °C (-40 °F)
	DN 50 ... 100 (2 ... 4")	25 bar (363 psi)	140 °C (284 °F)	-40 °C (-40 °F)
Pipe fitting (SMS 1145)	DN 25 ... 80 (1 ... 3")	6 bar (87 psi)	140 °C (284 °F)	-40 °C (-40 °F)
Tri-Clamp (DIN 32676)	DN 15 ... 50 (1/2 ... 2")	16 bar (232 psi)	120 °C (248 °F)	-40 °C (-40 °F)
	DN 65 ... 100 (2 1/2 ... 4")	10 bar (145 psi)	120 °C (248 °F)	-40 °C (-40 °F)

Material load curves for flange devices

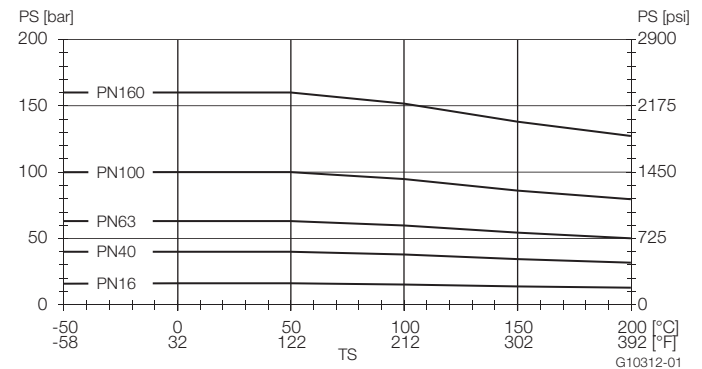

Fig. 12: Stainless steel DIN flange 1.4571 / 1.4404 (AISI 316Ti / 316L) up to DN 200 (8")

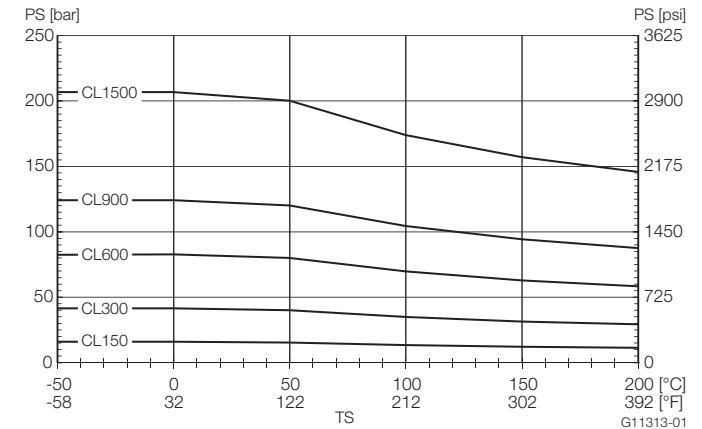

Fig. 13: Stainless steel ASME flange 1.4571 / 1.4404 (AISI 316Ti / 316L) up to DN 200 (8")

CoriolisMaster FCB430, FCB450, FCH430, FCH450

Coriolis mass flowmeter

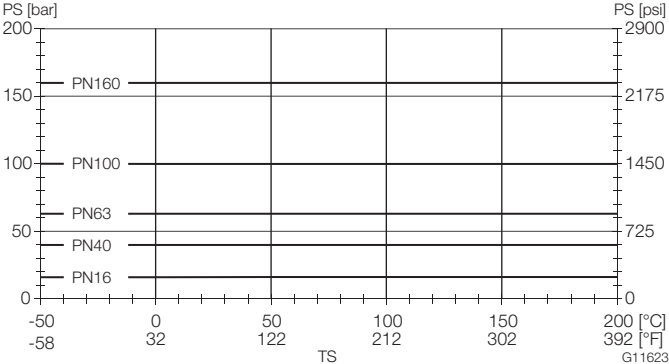

Fig. 14: Nickel alloy DIN flange C4 (2.4610) or nickel alloy C22 (2.4602) up to DN 200 (8")

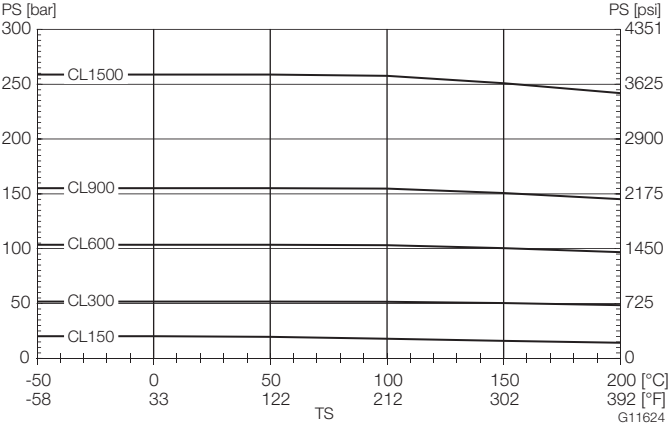

Fig. 15: Nickel alloy ASME flange C4 (2.4610) or nickel alloy C22 (2.4602) up to DN 200 (8")

Dimensions for devices with integral mount design

Devices with meter tube nominal diameter DN 15 ... 50 and flange DN 10 ... 65

Sensor with wetted parts made from stainless steel. All specified dimensions and weights are in mm (inch) or kg (lb).

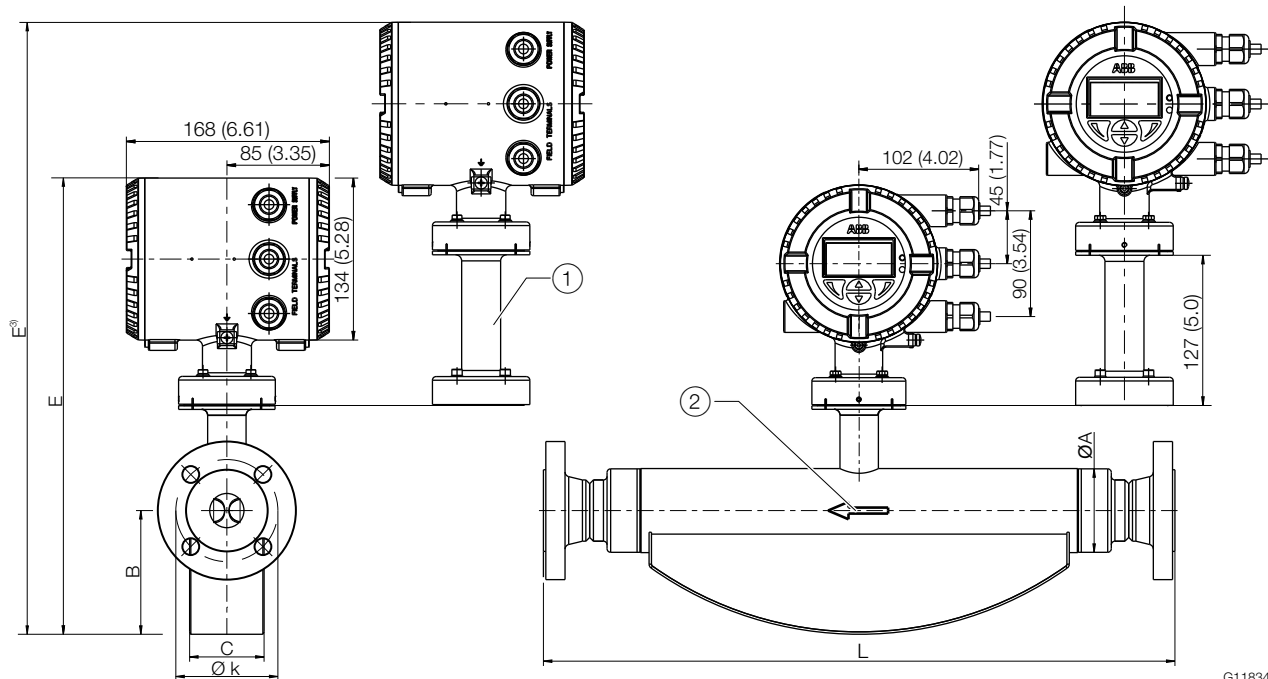

Fig. 16: Integral mount design with dual-compartment transmitter housing

① Option TE1 "Extended tower length" or option PR4 / PR5 / PR6 / PR7 "Pressure-resistant sensor housing" ② Flow direction

Meter tube nominal diameter DN 15 (1/2")							Approx. weight		
DN / process connection	L	Ø k	Ø A	B	C	E	Aluminum ¹⁾	Stainless steel ²⁾	
10 (3/8)	PN 40 (EN 1092-1 B1)	385 (15.2)	60 (2.4)	44.5 (1.8)	77 (3.0)	46 (1.8)	340 / 467 ³⁾ (13.39 / 18.39 ³⁾)	9 / 10 ³⁾ (19.8 / 22 ³⁾)	12 / 13 ³⁾ (26.5 / 28.7 ³⁾)
	JIS 10K	385 (15.2)	65 (2.6)						
15 (1/2)	PN 40 (EN 1092-1 B1)	385 (15.2)	65 (2.6)	44.5 (1.8)	77 (3.0)	46 (1.8)	340 / 467 ³⁾ (13.39 / 18.39 ³⁾)	9 / 10 ³⁾ (19.8 / 22 ³⁾)	12 / 13 ³⁾ (26.5 / 28.7 ³⁾)
	PN 63 (EN 1092-1 B2)	403 (15.9)	75 (3.0)						
	PN 100 (EN 1092-1 B2)	403 (15.9)	75 (3.0)						
	CL150 (ASME B16.5)	435 (17.1)	60.5 (2.4)						
	CL300 (ASME B16.5)	421 (16.6)	66.7 (2.6)						
	CL600 (ASME B16.5)	421 (16.6)	66.7 (2.6)						
	CL900 (ASME B16.5) CL1500 (ASME B16.5)	421 (16.6)	82.6 (3.3)						
JIS 10K	385 (15.2)	70 (2.8)							
20 (3/4)	PN 40 (EN 1092-1 B1)	421 (16.6)	75 (3.0)	44.5 (1.8)	77 (3.0)	46 (1.8)	340 / 467 ³⁾ (13.39 / 18.39 ³⁾)	9 / 10 ³⁾ (19.8 / 22 ³⁾)	12 / 13 ³⁾ (26.5 / 28.7 ³⁾)
	CL150 (ASME B16.5)	421 (16.6)	69.9 (2.8)						
	JIS 10K	421 (16.6)	75 (3.0)						

CoriolisMaster FCB430, FCB450, FCH430, FCH450

Coriolis mass flowmeter

Meter tube nominal diameter DN 25 (1")								Approx. weight	
DN / process connection		L	Ø k	Ø A	B	C	E	Aluminum ¹⁾	Stainless steel ²⁾
20 (3/4)	PN 40 (EN 1092-1 B1)	576 (22.7)	75 (3.0)	69.5 (2.74)	103 (4.06)	62 (2.44)	379 / 506 ³⁾ (14.92 / 19.92 ³⁾)	11 / 12 ³⁾ (24,3 / 26.5 ³⁾)	14 / 15 ³⁾ (30.9 / 33.1 ³⁾)
	CL150 (ASME B16.5)	575 (22.6)	69.9 (2.8)						
	JIS 10K	576 (22.7)	75 (3.0)						
25 (1)	PN 40 (EN 1092-1 B1)	525 (20.7)	85 (3.3)						
	PN 63 (EN 1092-1 B2)	564 (22.2)	100 (3.9)						
	PN 100 (EN 1092-1 B2)								
	CL150 (ASME B16.5)	575 (22.6)	79.2 (3.1)						
	CL300 (ASME B16.5)	576 (22.7)	88.9 (3.5)						
	CL600 (ASME B16.5)								
	CL900 (ASME B16.5)	576 (22.7)	82.6 (3.25)						
	CL1500 (ASME B16.5)								
JIS 10K	525 (20.7)	90 (3.54)							
40 (1 1/2)	PN 40 (EN 1092-1 B1)	576 (22.7)	110 (4.33)						
	PN 63 (EN 1092-1 B2)	572 (22.5)	125 (4.92)						
	PN 100 (EN 1092-1 B2)								
	CL150 (ASME B16.5)	576 (22.7)	98.6 (3.88)						
	CL300 (ASME B16.5)	576 (22.7)	114.3 (45.0)						
	CL600 (ASME B16.5)								
JIS 10K	576 (22.7)	105 (4.13)							

1) Devices with terminal boxes made from aluminum.

2) Devices with terminal boxes made from stainless steel.

3) Devices with option TE1 "extended tower length" or option PR4 / PR5 / PR6 / PR7 "pressure-resistant sensor housing".

Tolerance for dimension L: +0 / -3 mm (+0 / -0.018 inch)

Meter tube nominal diameter DN 50 (2")								Approx. weight	
DN / process connection		L	Ø k	Ø A	B	C	E	Aluminum ¹⁾	Stainless steel ²⁾
40 (1 1/2)	PN 40 (EN 1092-1 B1)	763 (30)	110 (4.33)	99 (3.9)	125 (4.92)	80 (3.15)	416 / 543 ³⁾ (16.38 / 21.38 ³⁾)	27 / 28 ³⁾ (59,5 / 61,7 ³⁾)	30 / 31 ³⁾ (66,1 / 68,3 ³⁾)
	PN 63 (EN 1092-1 B2)	745 (29.33)	125 (4.92)						
	PN 100 (EN 1092-1 B2)								
	CL150 (ASME B16.5)	763 (30)	98.6 (3.88)						
	CL300 (ASME B16.5)	756 (29.76)	114.3 (4.5)						
	CL600 (ASME B16.5)								
	CL900 (ASME B16.5)	780 (30.71)	124 (4.88)						
	CL1500 (ASME B16.5)								
JIS 10K	763 (30)	105 (4.13)							
50 (2)	PN 40 (EN 1092-1 B1)	715 (28.15)	125 (4.92)						
	PN 63 (EN 1092-1 B2)	745 (29.33)	135 (5.31)						
	PN 100 (EN 1092-1 B2)	745 (29.33)	145 (5.71)						
	CL150 (ASME B16.5)	715 (28.15)	120.7 (4.75)						
	CL300 (ASME B16.5)	763 (30)	127 (5.0)						
	CL600 (ASME B16.5)	773 (30.43)	127 (5.0)						
	CL900 (ASME B16.5)	790 (31.1)	165.1 (6.5)						
	CL1500 (ASME B16.5)								
JIS 10K	715 (28.15)	120 (4.72)							
65 (2 1/2)	PN 40 (EN 1092-1 B1)	763 (30)	145 (5.71)						
	CL150 (ASME B16.5)	756 (29.76)	139.7 (5.5)						
	CL900 (ASME B16.5)	800 (31.5)	190.5 (7.5)						
	CL1500 (ASME B16.5)								
	JIS 10K	763 (30)	140 (5.51)						

1) Devices with terminal boxes made from aluminum.

2) Devices with terminal boxes made from stainless steel.

3) Devices with option TE1 "extended tower length" or option PR4 / PR5 / PR6 / PR7 "pressure-resistant sensor housing".

Tolerance for dimension L: +0 / -3 mm (+0 / -0.018 inch)

CoriolisMaster FCB430, FCB450, FCH430, FCH450

Coriolis mass flowmeter

Devices with meter tube nominal diameter DN 80 and flange DN 65 ... 100

Sensor with wetted parts made from stainless steel. All specified dimensions and weights are in mm (inch) or kg (lb).

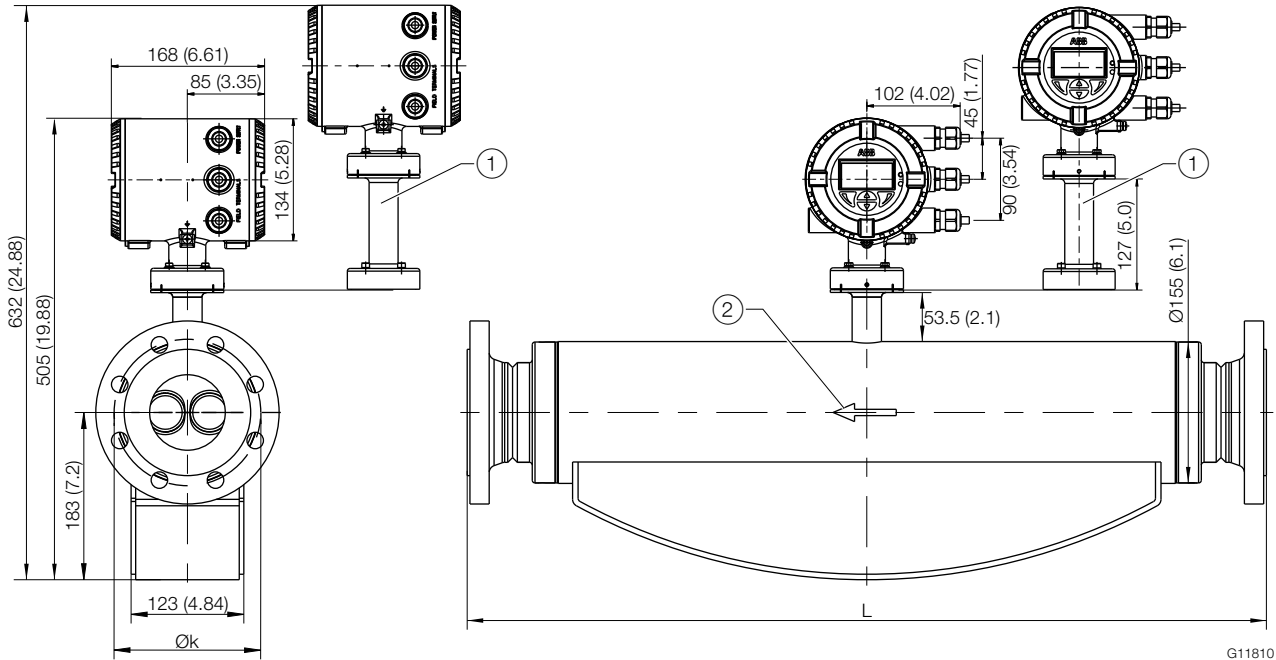

Fig. 17: Integral mount design with dual-compartment transmitter housing

① Option TE1 "Extended tower length" or option PR4 / PR5 / PR6 / PR7 "Pressure-resistant sensor housing" ② Flow direction

Meter tube nominal diameter DN 80 (3")			Approx. weight		
DN / process connection	L	Ø k	Aluminum ¹⁾	Stainless steel ²⁾	
65	PN 16 (EN 1092-1 B1)	— ⁴⁾	— ⁴⁾	— ⁴⁾	
(2 1/2")	PN 40 (EN 1092-1 B1)	910 (35.83)	145 (5.71)	70 / 71 ³⁾ (154.3 / 156.5 ³⁾	73 / 74 ³⁾ (160.9 / 163.1 ³⁾
	PN 63 (EN 1092-1 B2)		160 (6.30)	74 / 75 ³⁾ (163.1 / 165.4 ³⁾	77 / 78 ³⁾ (169.8 / 172.0 ³⁾
	PN 100 (EN 1092-1 B2)		170 (6.69)	78 / 79 ³⁾ (172 / 174.2 ³⁾	81 / 82 ³⁾ (178.6 / 180.8 ³⁾
	CL150 (ASME B16.5)	— ⁴⁾	— ⁴⁾	— ⁴⁾	
	CL300 (ASME B16.5)	920 (36.22)	149.4 (5.88)	72 / 73 ³⁾ (158.7 / 160.9 ³⁾	75 / 76 ³⁾ (163.1 / 167.6 ³⁾
	CL600 (ASME B16.5)			73 / 74 ³⁾ (160.9 / 163.1 ³⁾	76 / 77 ³⁾ (167.6 / 169.8 ³⁾
	CL900 (ASME B16.5)	965 (37.99)	190.5 (7.50)	90 / 91 ³⁾ (198.4 / 200.6 ³⁾	93 / 94 ³⁾ (205.3 / 207.23 ³⁾
	CL1500 (ASME B16.5)				
	JIS 10K	910 (35.83)	140 (5.5)	70 / 71 ³⁾ (154.3 / 156.5 ³⁾	73 / 74 ³⁾ (160.9 / 163.1 ³⁾

1) Devices with terminal boxes made from aluminum.

2) Devices with terminal boxes made from stainless steel.

3) Devices with option TE1 "extended tower length" or option PR4 / PR5 / PR6 / PR7 "pressure-resistant sensor housing".

4) On request

Tolerance for dimension L: +0 / -3 mm (+0 / -0.018 inch)

Meter tube nominal diameter DN 80 (3")				Approx. weight		
DN / process connection	L	Ø k	Aluminum ¹⁾	Stainless steel ²⁾		
80 (3")	PN 16 (EN 1092-1 B1)	870 (34.25)	160 (6.30)	70 / 71 ³⁾ (154.3 / 156.5 ³⁾)	73 / 74 ³⁾ (160.9 / 163.1 ³⁾)	
	PN 40 (EN 1092-1 B1)			71 / 72 ³⁾ (156.5 / 158.7 ³⁾)	74 / 75 ³⁾ (163.1 / 165.4 ³⁾)	
	PN 63 (EN 1092-1 B2)	910 (35.83)	170 (6.69)	75 / 76 ³⁾ (163.1 / 167.6 ³⁾)	78 / 79 ³⁾ (172.0 / 174.2 ³⁾)	
	PN 100 (EN 1092-1 B2)			81 / 82 ³⁾ (178.6 / 180.8 ³⁾)	84 / 85 ³⁾ (185.2 / 187.4 ³⁾)	
	CL150 (ASME B16.5)	880 (34.65)	152.4 (6.00)	71 / 72 ³⁾ (156.5 / 158.7 ³⁾)	74 / 75 ³⁾ (163.1 / 165.4 ³⁾)	
	CL300 (ASME B16.5)	895 (35.24)	168.1 (6.62)	75 / 76 ³⁾ (163.1 / 167.6 ³⁾)	78 / 79 ³⁾ (172.0 / 174.2 ³⁾)	
	CL600 (ASME B16.5)	920 (36.22)		78 / 79 ³⁾ (172.0 / 174.2 ³⁾)	81 / 82 ³⁾ (178.6 / 180.8 ³⁾)	
	CL900 (ASME B16.5)	1100 (43.31)	190.5 (7.50)	90 / 91 ³⁾ (198.4 / 200.6 ³⁾)	93 / 94 ³⁾ (205.3 / 207.23 ³⁾)	
	CL1500 (ASME B16.5)	1300 (51.18)	203.2 (8.00)	102 / 103 ³⁾ (224.9 / 227.0 ³⁾)	105 / 106 ³⁾ (231.5 / 233.7 ³⁾)	
	JIS 10K	870 (34.25)	150 (5.91)	71 / 72 ³⁾ (156.5 / 158.7 ³⁾)	74 / 75 ³⁾ (163.1 / 165.4 ³⁾)	
100 (4")	PN 16 (EN 1092-1 B1)	875 (34.45)	190 (7.48)	71 / 72 ³⁾ (156.5 / 158.7 ³⁾)	74 / 75 ³⁾ (163 / 165.3 ³⁾)	
	PN 40 (EN 1092-1 B1)			73 / 74 ³⁾ (161 / 163 ³⁾)	76 / 77 ³⁾ (167.6 / 170 ³⁾)	
	PN 63 (EN 1092-1 B2)	1060 (41.73)	200 (7.87)	82 / 83 ³⁾ (180.8 / 183.0 ³⁾)	85 / 86 ³⁾ (187.4 / 189.6 ³⁾)	
	PN 100 (EN 1092-1 B2)	1080 (42.52)	210 (8.27)	90 / 91 ³⁾ (198.4 / 200.6 ³⁾)	93 / 94 ³⁾ (205.3 / 207.23 ³⁾)	
	CL150 (ASME B16.5)	880 (34.65)	190.5 (7.50)	73 / 74 ³⁾ (160.9 / 163.1 ³⁾)	76 / 77 ³⁾ (167.6 / 169.8 ³⁾)	
	CL300 (ASME B16.5)	1075 (42.32)	200.2 (7.88)	87 / 88 ³⁾ (191.8 / 194.0 ³⁾)	90 / 91 ³⁾ (198.4 / 200.6 ³⁾)	
	CL600 (ASME B16.5)	1100 (43.31)	215.9 (8.50)	97 / 98 ³⁾ (213.9 / 216.1 ³⁾)	100 / 101 ³⁾ (220.5 / 222.7 ³⁾)	
	CL900 (ASME B16.5)	1130 (44.49)	234.9 (9.25)	107 / 108 ³⁾ (235.9 / 238.1 ³⁾)	110 / 111 ³⁾ (242.5 / 244.7 ³⁾)	
	CL1500 (ASME B16.5)	1150 (45.28)	241.3 (9.50)	122 / 123 ³⁾ (269.0 / 271.2 ³⁾)	125 / 126 ³⁾ (275.6 / 277.8 ³⁾)	

1) Devices with terminal boxes made from aluminum.

2) Devices with terminal boxes made from stainless steel.

3) Devices with option TE1 "extended tower length" or option PR4 / PR5 / PR6 / PR7 "pressure-resistant sensor housing".

4) On request

Tolerance for dimension L: +0 / -3 mm (+0 / -0.018 inch)

CoriolisMaster FCB430, FCB450, FCH430, FCH450

Coriolis mass flowmeter

Devices with meter tube nominal diameter DN 100 and flange DN 80 ... 100

Sensor with wetted parts made from stainless steel. All specified dimensions and weights are in mm (inch) or kg (lb).

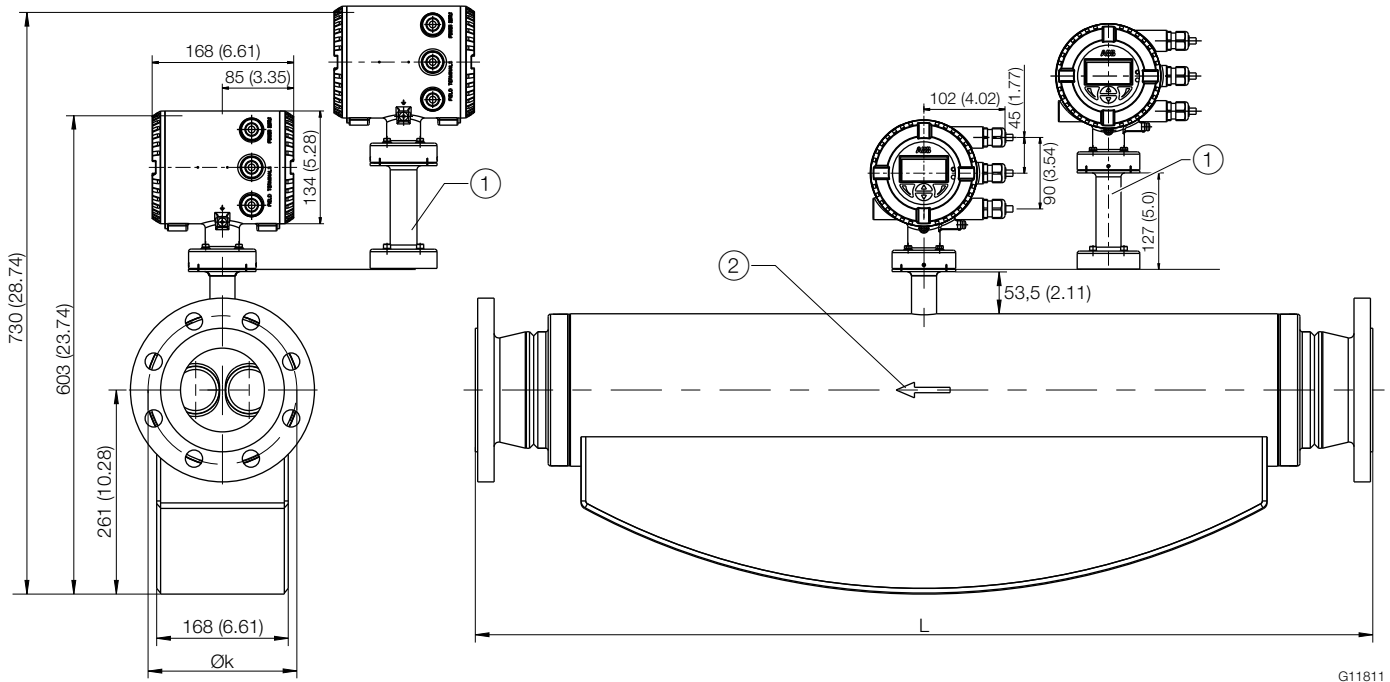

G11811

Fig. 18: Integral mount design with dual-compartment transmitter housing

① Option TE1 "Extended tower length" or option PR4 / PR5 / PR6 / PR7 "Pressure-resistant sensor housing" ② Flow direction

Meter tube nominal diameter DN 100 (4")			Approx. weight		
DN / process connection	L	Ø k	Aluminum ¹⁾	Stainless steel ²⁾	
80 (3")	PN 16 (EN 1092-1 B1)	1222 (48.11)	122 / 123 ³⁾ (269 / 271 ³⁾)	124 / 126 ³⁾ (273 / 278 ³⁾)	
	PN 40 (EN 1092-1 B1)				123 / 124 ³⁾ (271 / 273 ³⁾)
	PN 63 (EN 1092-1 B2)	1234 (48.58)	127 / 128 ³⁾ (280 / 282 ³⁾)	129 / 130 ³⁾ (284 / 287 ³⁾)	
	PN 100 (EN 1092-1 B2)		129 / 130 ³⁾ (284 / 287 ³⁾)	131 / 132 ³⁾ (289 / 291 ³⁾)	
	CL150 (ASME B16.5)	1244 (48.98)	152.4 (6.00)	124 / 125 ³⁾ (273 / 276 ³⁾)	126 / 127 ³⁾ (278 / 280 ³⁾)
	CL300 (ASME B16.5)		168.1 (6.62)	132 / 133 ³⁾ (291 / 293 ³⁾)	134 / 135 ³⁾ (295 / 298 ³⁾)
	CL600 (ASME B16.5)		168.1 (6.62)	135 / 136 ³⁾ (298 / 300 ³⁾)	137 / 138 ³⁾ (302 / 304 ³⁾)
	CL900 (ASME B16.5)	1470 (57.87)	190.5 (7.50)	138 / 139 ³⁾ (304 / 306 ³⁾)	140 / 141 ³⁾ (307 / 311 ³⁾)
CL1500 (ASME B16.5)	1500 (59.05)	203.2 (8.00)	150 / 151 ³⁾ (331 / 335 ³⁾)	152 / 153 ³⁾ (355 / 337 ³⁾)	
JIS 10K	1275 (50.20)	150 (5.91)	119 / 120 ³⁾ (262 / 265 ³⁾)	122 / 123 ³⁾ (269 / 271 ³⁾)	

Meter tube nominal diameter DN 100 (4")				Approx. weight		
DN / process connection	L	Ø k	Aluminum ¹⁾	Stainless steel ²⁾		
100 (4")	PN 16 (EN 1092-1 B1)	1122 (44.17)	180 (7.09)	119 / 120 ³⁾ (262 / 265 ³⁾)	122 / 123 ³⁾ (269 / 271 ³⁾)	
	PN 40 (EN 1092-1 B1)	1144 (45.04)	190 (7.48)	122 / 123 ³⁾ (269 / 271 ³⁾)	125 / 126 ³⁾ (276 / 278 ³⁾)	
	PN 63 (EN 1092-1 B2)	1304 (51.34)	138 (5.43)	129 / 130 ³⁾ (248 / 287 ³⁾)	132 / 133 ³⁾ (291 / 293 ³⁾)	
	PN 100 (EN 1092-1 B2)	1334 (52.52)	150 (5.91)	137 / 138 ³⁾ (302 / 304 ³⁾)	140 / 141 ³⁾ (309 / 311 ³⁾)	
	CL150 (ASME B16.5)	1144 (45.04)	190.5 (7.50)	123 / 124 ³⁾ (271 / 273 ³⁾)	126 / 127 ³⁾ (278 / 280 ³⁾)	
	CL300 (ASME B16.5)	1324 (52.13)	200.2 (7.88)	135 / 136 ³⁾ (298 / 300 ³⁾)	138 / 139 ³⁾ (304 / 306 ³⁾)	
	CL600 (ASME B16.5)	1354 (53.31)	215.9 (8.50)	137 / 138 ³⁾ (302 / 304 ³⁾)	140 / 141 ³⁾ (309 / 311 ³⁾)	
	CL900 (ASME B16.5)	1380 (54.33)	234.9 (9.25)	157 / 158 ³⁾ (346 / 348 ³⁾)	159 / 160 (350 / 353 ³⁾)	
	CL1500 (ASME B16.5)	1400 (55.12)	241.3 (9.50)	171 / 172 ³⁾ (377 / 379 ³⁾)	173 / 174 ³⁾ (381 / 384 ³⁾)	
	JIS 10K	1150 (45.28)	175 (6.89)	122 / 123 ³⁾ (269 / 271 ³⁾)	125 / 126 ³⁾ (276 / 278 ³⁾)	
150 (6")	PN 16 (EN 1092-1 B1)	1260 (49.61)	240 (9.44)	128 / 129 ³⁾ (282 / 284 ³⁾)	130 / 131 ³⁾ (287 / 289 ³⁾)	
	PN 40 (EN 1092-1 B1)		250 (9.84)	136 / 137 ³⁾ (300 / 302 ³⁾)	138 / 139 ³⁾ (304 / 306 ³⁾)	
	CL150 (ASME B16.5)	1330 (52.36)	241.3 (9.50)	133 / 134 ³⁾ (293 / 295 ³⁾)	136 / 137 ³⁾ (300 / 302 ³⁾)	
	JIS 10K	1275 (50.20)	240 (9.44)	126 / 127 ³⁾ (278 / 280 ³⁾)	129 / 130 ³⁾ (284 / 287 ³⁾)	

1) Devices with terminal boxes made from aluminum.

2) Devices with terminal boxes made from stainless steel.

3) Devices with option TE1 "extended tower length" or option PR4 / PR5 / PR6 / PR7 "pressure-resistant sensor housing".

Tolerance for dimension L: +0 / -3 mm (+0 / -0.018 inch)

CoriolisMaster FCB430, FCB450, FCH430, FCH450

Coriolis mass flowmeter

Devices with meter tube nominal diameter DN 150 and flange DN 150

Sensor with wetted parts made from stainless steel. All specified dimensions and weights are in mm (inch) or kg (lb).

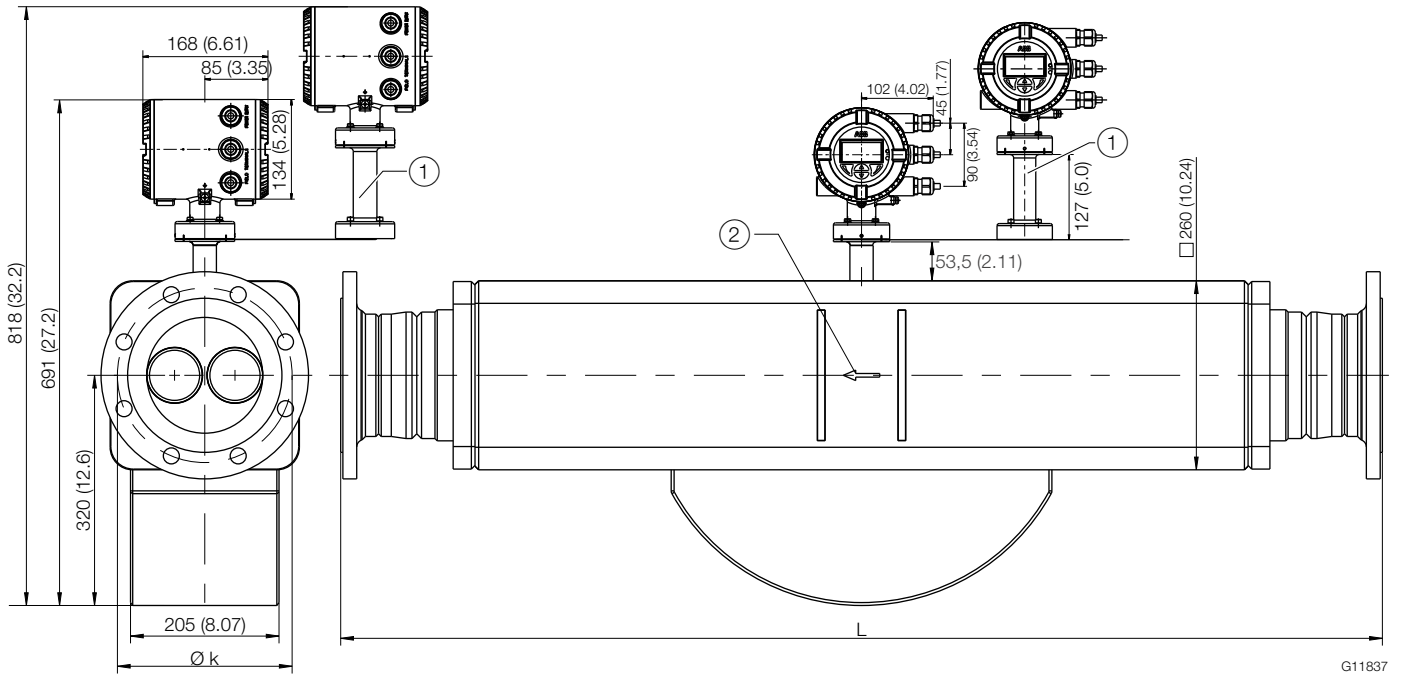

Fig. 19: Integral mount design with dual-compartment transmitter housing

① Option TE1 "Extended tower length" or option PR4 / PR5 / PR6 / PR7 "Pressure-resistant sensor housing" ② Flow direction

Dimensions for sensors featuring meter tubes with nominal diameter DN 150 (6")			Approx. weight	
DN / process connection	L	$\varnothing k$	Aluminum ¹⁾	Stainless steel ²⁾
100 (4")	PN 16 (EN 1092-1 B1)	1569 (61.77)	171 / 172 ³⁾ (377 / 379 ³⁾)	174 / 175 ³⁾ (384 / 386 ³⁾)
	PN 40 (EN 1092-1 B1)	1599 (62.95)	175 / 176 ³⁾ (386 / 388 ³⁾)	178 / 179 ³⁾ (392 / 395 ³⁾)

1) Devices with transmitter housing made from aluminum.

2) Devices with transmitter housing made from stainless steel.

3) Devices with option TE1 "extended tower length" or option PR4 / PR5 / PR6 / PR7 "pressure-resistant sensor housing".

Tolerance for dimension L: +0 / -5 mm (+0 / -0.2 inch)

Dimensions for sensors featuring meter tubes with nominal diameter DN 150 (6")				Approx. weight	
DN / process connection		L	∅ k	Aluminum ¹⁾	Stainless steel ²⁾
150 (6")	PN 16 (EN 1092-1 B1)	1421 (55.94)	240 (9.45)	174 / 175 ³⁾ (384 / 386 ³⁾)	177 / 178 ³⁾ (390 / 392 ³⁾)
	PN 40 (EN 1092-1 B1)	1461 (57.52)	250 (9.84)	182 / 183 ³⁾ (401 / 403 ³⁾)	185 / 186 ³⁾ (407 / 410 ³⁾)
	CL150 (ASME B16.5)	1485 (58.46)	241.3 (9.50)	181 / 182 ³⁾ (399 / 401 ³⁾)	184 / 185 ³⁾ (405 / 408 ³⁾)
	CL300 (ASME B16.5)	1505 (59.25)	269.7 (10.62)	199 / 200 ³⁾ (439 / 441 ³⁾)	202 / 203 ³⁾ (455 / 448 ³⁾)
	CL600 (ASME B16.5)	1555 (61.22)	292.1 (11.50)	221 / 222 ³⁾ (487 / 489 ³⁾)	224 / 225 ³⁾ (494 / 496 ³⁾)
	CL900 (ASME B16.5)	1605 (63.19)	317.5 (12.5)	245 / 246 ³⁾ (540 / 542 ³⁾)	248 / 249 ³⁾ (547 / 549 ³⁾)
	CL1500 (ASME B16.5)	1665 (65.55)		287 / 288 ³⁾ (633 / 635 ³⁾)	290 / 291 ³⁾ (639 / 642 ³⁾)
200 (8")	PN 40 (EN 1092-1 B1)	1637 (64.45)	320 (12.6)	206 / 207 ³⁾ (454 / 456 ³⁾)	208 / 209 ³⁾ (459 / 461 ³⁾)
	CL150 (ASME B16.5)	1650 (64.96)	298.5 (11.75)	201 / 202 ³⁾ (443 / 445 ³⁾)	203 / 204 ³⁾ (448 / 450 ³⁾)
	CL300 (ASME B16.5)	1670 (65.75)	330.2 (13.0)	225 / 226 ³⁾ (496 / 498 ³⁾)	228 / 229 ³⁾ (503 / 505 ³⁾)

1) Devices with transmitter housing made from aluminum.

2) Devices with transmitter housing made from stainless steel.

3) Devices with option TE1 "extended tower length" or option PR4 / PR5 / PR6 / PR7 "pressure-resistant sensor housing".

Tolerance for dimension L: +0 / -5 mm (+0 / -0.2 inch)

CoriolisMaster FCB430, FCB450, FCH430, FCH450

Coriolis mass flowmeter

Devices DN 15 ... 150 in NAMUR standard installation lengths (order option S5, S7)

Sensor with wetted parts made from stainless steel. All specified dimensions and weights are in mm (inch) or kg (lb).

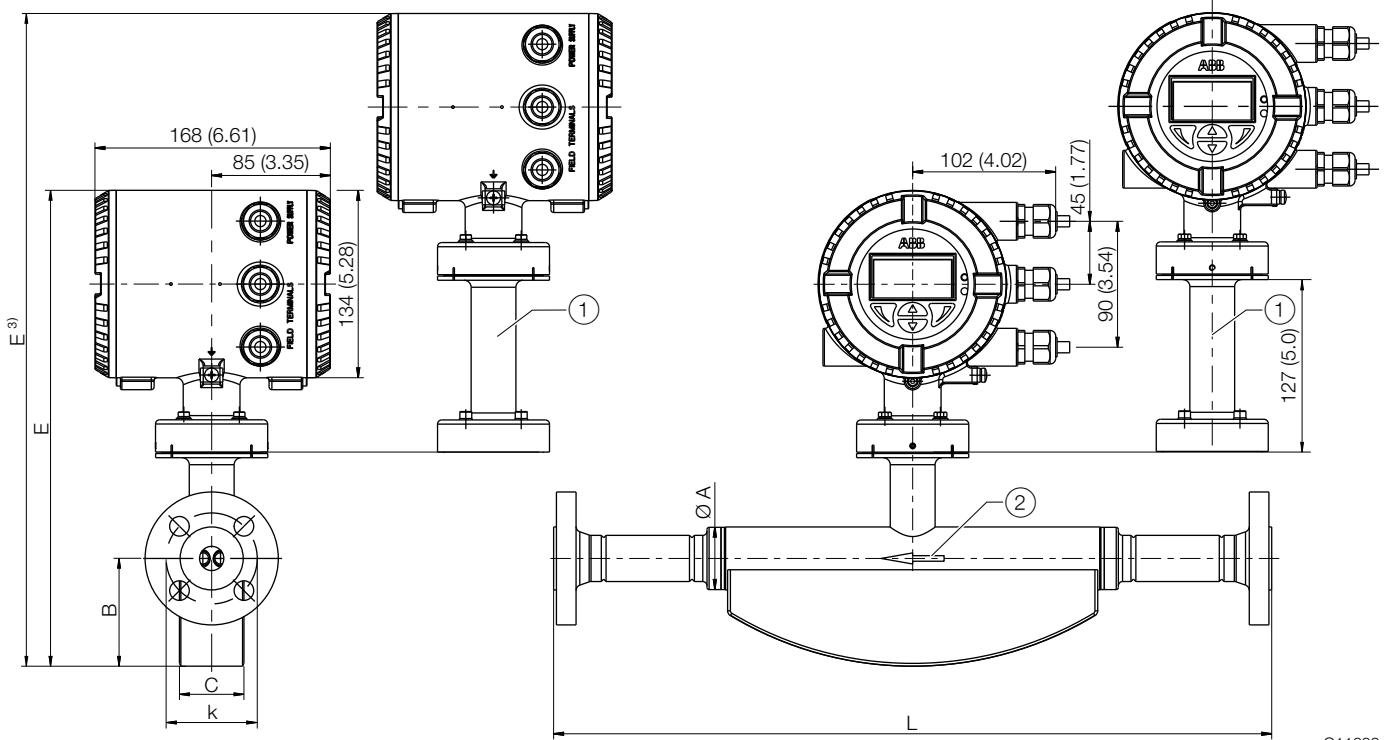

G11833

Fig. 20: Devices in integral mount design, tolerance for dimension L: +0 / -3 mm (+0 / -0.018 inch)

① Option TE1 "Extended tower length" or option PR4 / PR5 / PR6 / PR7 "Pressure-resistant sensor housing" ② Flow direction

Devices DN 15 ... 150 in NAMUR standard installation lengths									
Meter tube	Process connection EN 1092-1 B1	L	Ø k	Ø A	B	C	E	Approx. weight	
								Aluminum ¹⁾	Stainless steel ²⁾
DN 15 (1/2")	DN 15 (1/2") / PN 40	510 (20.08)	60 (2.4)	44.5 (1.8)	77 (3.0)	46 (1.8)	340 / 467 ³⁾ (13.39 / 18.39 ³⁾)	9.5 / 10.5 ³⁾ (20.9 / 23.2 ³⁾)	12.5 / 13.5 ³⁾ (27.6 / 29.8 ³⁾)
DN 25 (1")	DN 25 (1") / PN 40	600 (23.62)	75 (3.0)	69.5 (2.74)	103 (4.06)	62 (2.44)	379 / 506 ³⁾ (14.92 / 19.92 ³⁾)	11 / 12 ³⁾ (24.3 / 26.53 ³⁾)	14 / 15 ³⁾ (30.9 / 33.1 ³⁾)
DN 50 (1")	DN 50 (1") / PN 40	715 (28.15)	125 (4.92)	99 (3.9)	125 (4.92)	80 (3.15)	416 / 543 ³⁾ (16.38 / 21.38 ³⁾)	27 / 28 ³⁾ (59.5 / 61.7 ³⁾)	30 / 31 ³⁾ (66.1 / 68.3 ³⁾)
DN 80 (3")	DN 80 (3") / PN 40	915 (36.02)	160 (6.30)	155 (6.1)	183 (7.2)	123 (4.84)	505 / 632 ³⁾ (19.88 / 24.88 ³⁾)	70 / 71 ³⁾ (154 / 157 ³⁾)	73 / 74 ³⁾ (161 / 163 ³⁾)
DN 100 (4")	DN 100 (4") / PN 16	1400 (55.12)	180 (7.09)	195 (7.68)	261 (10.28)	168 (6.61)	603 / 730 ³⁾ (23.74 / 28.74 ³⁾)	119 / 120 ³⁾ (262 / 265 ³⁾)	122 / 123 ³⁾ (269 / 271 ³⁾)
DN 150 (6")	DN 150 (6") / PN 16	1700 (66.93)	240 (9.45)	260 (10.24)	320 (12.6)	205 (8.07)	691 / 818 ³⁾ (27.2 / 32.2 ³⁾)	174 / 175 ³⁾ (384 / 386 ³⁾)	177 / 178 ³⁾ (390 / 392 ³⁾)

1) Devices with terminal boxes made from aluminum.

2) Devices with terminal boxes made from stainless steel.

3) Devices with option TE1 "extended tower length" or option PR4 / PR5 / PR6 / PR7 "pressure-resistant sensor housing".

Devices with meter tube nominal diameter DN 15 ... 80 and connections in accordance with SMS 1145, DIN 11851, DIN 32676, DIN ISO 228, ASME BPE and ASME B 1.20.1

Sensor with wetted parts made from stainless steel. All specified dimensions and weights are in mm (inch) or kg (lb).

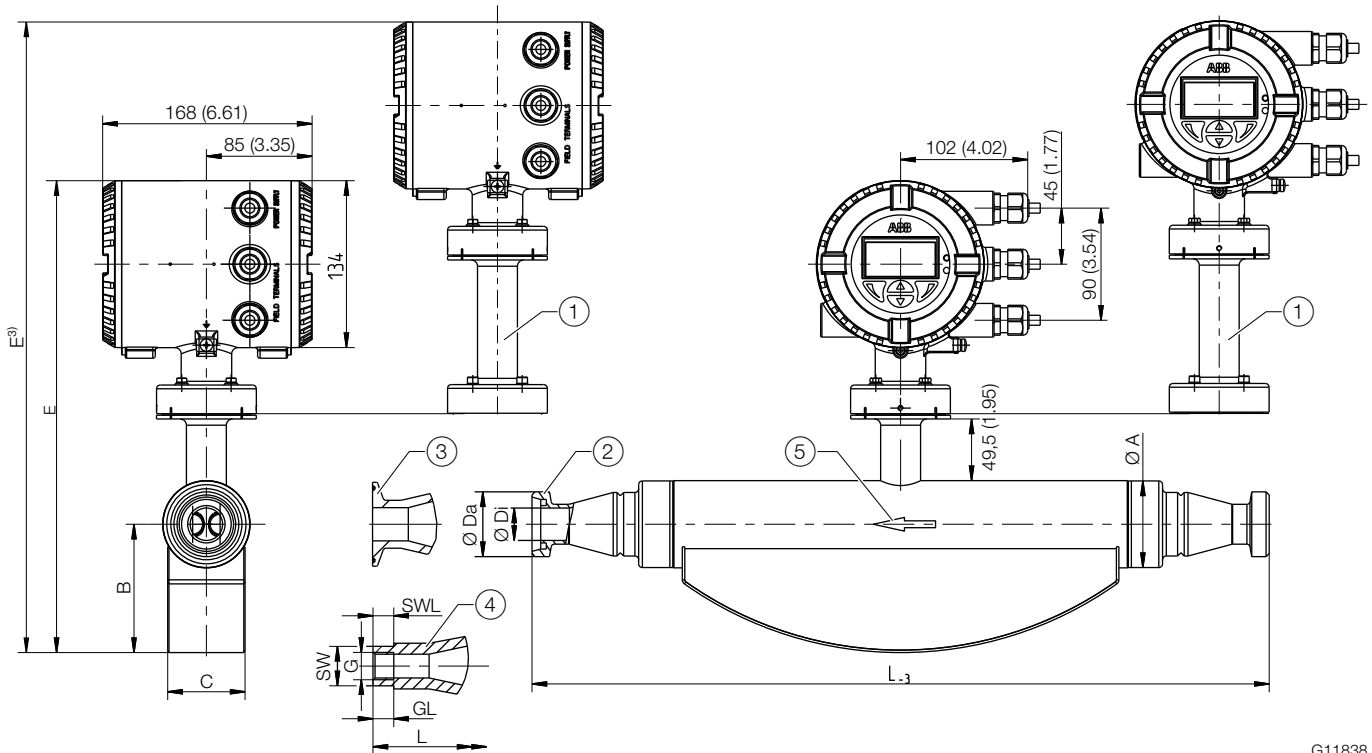

G11838

Fig. 21: Integral mount design with dual-compartment transmitter housing

① Option TE1 "extended tower length or option PR4 / PR5 / PR6 / PR7 "pressure-resistant sensor housing" ② threaded spud in accordance with DIN 11851 and SMS 1145 ③ Clamping connection in accordance with DIN 32676 and ASME BPE ④ Female thread connection in accordance with DIN ISO 228 and ASME B 1.20.1 ⑤ Flow direction

Process connection in accordance with SMS 1145 meter tube nominal diameter DN 25 ... 80 (1" ... 3")

Meter tube DN	Process connection		L	Ø DA	Ø Di	Ø A	B	C	E	Approx. weight		
	DN	PN								Aluminum ¹⁾	Stainless steel ²⁾	
25 (1")	25 (1")	6	590 (23.2)	RD 40x1/6"	22.6 (0.89)	69.5 (2.74)	103 (4.06)	62 (2.44)	379 / 506 ³⁾ (14.92 / 19.92 ³⁾)	13 (29)	14 (31)	
	40 (1 1/2")			RD 60x1/6"								38 (1.50)
50 (2")	40 (1 1/2")	6	763 (30.0)	RD 60x1/6"	35.5 (1.40)	99 (3.46)	125 (4.92)	80 (3.15)	416 / 543 ³⁾ (16.38 / 21.38 ³⁾)	29 (64)	30 (66)	
	50 (2")			RD 70x1/6"								48.5 (1.91)
	65 (2 1/2")			RD 85x1/6"								60.5 (2.38)
80 (3")	65 (2 1/2")	6	990 (39.0)	RD 85x1/6"	60.5 (2.38)	155 (6.10)	183 (7.20)	123 (4.84)	505 / 632 ³⁾ (19.88 / 24.88 ³⁾)	70 (154)	71 (156)	
	80 (3")			RD 98x1/4"								72.6 (2.86)

CoriolisMaster FCB430, FCB450, FCH430, FCH450

Coriolis mass flowmeter

Process connection in accordance with DIN 11851 meter tube nominal diameter DN 15 ... 80 (1/2" ... 3")												
Meter tube	Process connection		L	Ø DA	Ø Di	Ø A	B	C	E	Approx. weight		
	DN	PN								Aluminum ¹⁾	Stainless steel ²⁾	
15 (1/2")	10 (3/8")	40	413 (16.3)	RD 28x1/8"	10 (0.39)	44.5	77	46	340 / 467 ³⁾	9 / 10 ³⁾	12 / 13 ³⁾	
	15 (1/2")			RD 34x1/8"	16 (0.63)							(1.75)
	20 (3/4")			RD 44x1/6"	20 (0.79)							
25 (1")	20 (3/4")	25	590 (23.2)	RD 44x1/6"	20 (0.79)	69.5	103	62	379 / 506 ³⁾	11 / 12 ³⁾	14 / 15 ³⁾	
	25 (1")			RD 52x1/6"	26 (1.02)							(2.74)
	40 (1 1/2")			RD 65x1/6"	38 (1.5)							
50 (2")	40 (1 1/2")	25	763 (30.0)	RD 65x1/6"	38 (1.5)	99	125	80	416 / 543 ³⁾	27 / 28 ³⁾	30 / 31 ³⁾	
	50 (2")			RD 78x1/6"	50 (1.97)							(3.46)
	65 (2 1/2")			RD 95x1/6"	66 (2.6)							
80 (3")	65 (2 1/2")	25	990 (39.0)	RD 95x1/6"	66 (2.6)	155	183	123	505 / 632 ³⁾	68 / 69 ³⁾	71 / 72 ³⁾	
	80 (3")			RD 110x1/4"	81 (3.19)							(6.10)
	100 (4")			RD 130x1/4"	100 (3.94)							

Process connection in accordance with DIN 32676 meter tube nominal diameter DN 15 ... 80 (1/2" ... 3")												
Meter tube	Process connection		L	Ø DA	Ø Di	Ø A	B	C	E	Approx. weight		
	DN	PN								Aluminum ¹⁾	Stainless steel ²⁾	
15 (1/2")	10 (3/8")	40	413 (16.3)	34 (1.34)	10 (0.39)	44.5	77	46	340 / 467 ³⁾	9 / 10 ³⁾	12 / 13 ³⁾	
	15 (1/2")				16 (0.63)							(1.75)
	20 (3/4")				20 (0.79)							
25 (1")	20 (3/4")	25	590 (23.2)	50.5 (1.99)	20 (0.79)	69.5	103	62	379 / 506 ³⁾	11 / 12 ³⁾	14 / 15 ³⁾	
	25 (1")				26 (1.02)							(2.74)
	40 (1 1/2")				38 (1.5)							
50 (2")	40 (1 1/2")	25	763 (30.0)	64 (2.52)	38 (1.5)	99	125	80	416 / 543 ³⁾	27 / 28 ³⁾	30 / 31 ³⁾	
	50 (2")				50 (1.97)							(3.46)
	65 (2 1/2")				66 (2.6)							
80 (3")	65 (2 1/2")	10	950 (37.4)	106 (4.17)	66 (2.6)	155	183	123	505 / 632 ³⁾	68 / 69 ³⁾	71 / 72 ³⁾	
	80 (3")				81 (3.19)							(6.10)
	100 (4")				119 (4.69)							

1) Devices with terminal boxes made from aluminum.

2) Devices with terminal boxes made from stainless steel.

3) Devices with option TE1 "extended tower length" or option PR4 / PR5 / PR6 / PR7 "pressure-resistant sensor housing".

Tolerance for dimension L: +0 / -3 mm (+0 / -0.018 inch)

Process connection in accordance with ASME BPE meter tube nominal diameter DN 15 ... 80 (1/2" ... 3")											
Meter tube	Process connection		L	Ø DA	Ø Di	Ø A	B	C	E	Approx. weight	
DN	DN	PN								Aluminum ¹⁾	Stainless steel ²⁾
15 (1/2")	3/8"-Type A	10	—	—	—	44.5 (1.75)	77 (3.03)	46 (1.81)	340 / 467 ³⁾ (13.39 / 18.39 ³⁾)	9 / 10 ³⁾ (20 / 22 ³⁾)	12 / 13 ³⁾ (27 / 29 ³⁾)
	1/2"-Type A		433 (17.05)	25 (0.98)	9.4 (0.37)						
	3/4"-Type A		—	—	—						
25 (1")	3/4"-Type A	10	—	—	—	69.5 (2.74)	103 (4.06)	62 (2.44)	379 / 506 ³⁾ (14.92 / 19.92 ³⁾)	11 / 12 ³⁾ (24 / 27 ³⁾)	14 / 15 ³⁾ (31 / 33 ³⁾)
	1"-Type B		590 (23.23)	50.4 (1.98)	22.1 (0.87)						
	1 1/2"-Type B		590 (23.23)	50.4 (1.98)	34.8 (1.37)						
50 (2")	1 1/2"-Type B	10	—	—	—	99 (3.46)	125 (4.92)	80 (3.15)	416 / 543 ³⁾ (16.38 / 21.38 ³⁾)	27 / 28 ³⁾ (60 / 62 ³⁾)	30 / 31 ³⁾ (66 / 68 ³⁾)
	2"-Type B		740 (29.13)	63.9 (2.52)	47.5 (1.87)						
	2 1/2"-Type B		—	—	—						
80 (3")	2 1/2"-Type B	10	950 (37.40)	77.4 (3.05)	60.2 (2.37)	155 (6.10)	183 (7.20)	183 (7.20)	505 / 632 ³⁾ (19.88 / 24.88 ³⁾)	68 / 69 ³⁾ (150 / 152 ³⁾)	71 / 72 ³⁾ (157 / 159 ³⁾)
	3"-Type B		910 (35.83)	90.9 (3.19)	72.9 (2.87)						
	4"-Type B		910 (35.83)	118.9 (4.68)	97.4 (3.83)						

Process connection in accordance with DIN ISO 228 and ASME B 1.20.1, meter tube nominal diameter DN 15 ... 80 (1/2" ... 3")												
Meter tube	Process connection		L	GL	WS ⁴⁾	SWL	Ø A	B	C	E	Approx. weight	
DN	DN / G	PN									Aluminum ¹⁾	Stainless steel ²⁾
15 (1/2")	8 (1/4") / G 1/4"	100	450 (17.72)	10 (0.39)	19	10 (0.39)	44.5 (1.75)	77 (3.03)	46 (1.81)	340 / 467 ³⁾ (13.39 / 18.39 ³⁾)	9 / 10 ³⁾ (20 / 22 ³⁾)	12 / 13 ³⁾ (27 / 29 ³⁾)
	15 (1/2") / G 1/2"			13.5 (0.53)	27	15 (0.59)						
	25 (1") / G 1"			17 (0.67)	50	20 (0.79)						
	15 (1/2") / 1/2" NPT			15.6 (0.61)	27	15 (0.59)						

1) Devices with terminal boxes made from aluminum.

2) Devices with terminal boxes made from stainless steel.

3) Devices with option TE1 "extended tower length" or option PR4 / PR5 / PR6 / PR7 "pressure-resistant sensor housing".

4) Dimension SW: Width across flats specified in mm.

Tolerance for dimension L: +0 / -3 mm (+0 / -0.018 inch)

CoriolisMaster FCB430, FCB450, FCH430, FCH450

Coriolis mass flowmeter

Dimensions for devices with remote mount design

Devices with meter tube nominal diameter DN 15 ... 50 and flange DN 10 ... 65

Sensor with wetted parts made from stainless steel. All specified dimensions and weights are in mm (inch) or kg (lb).

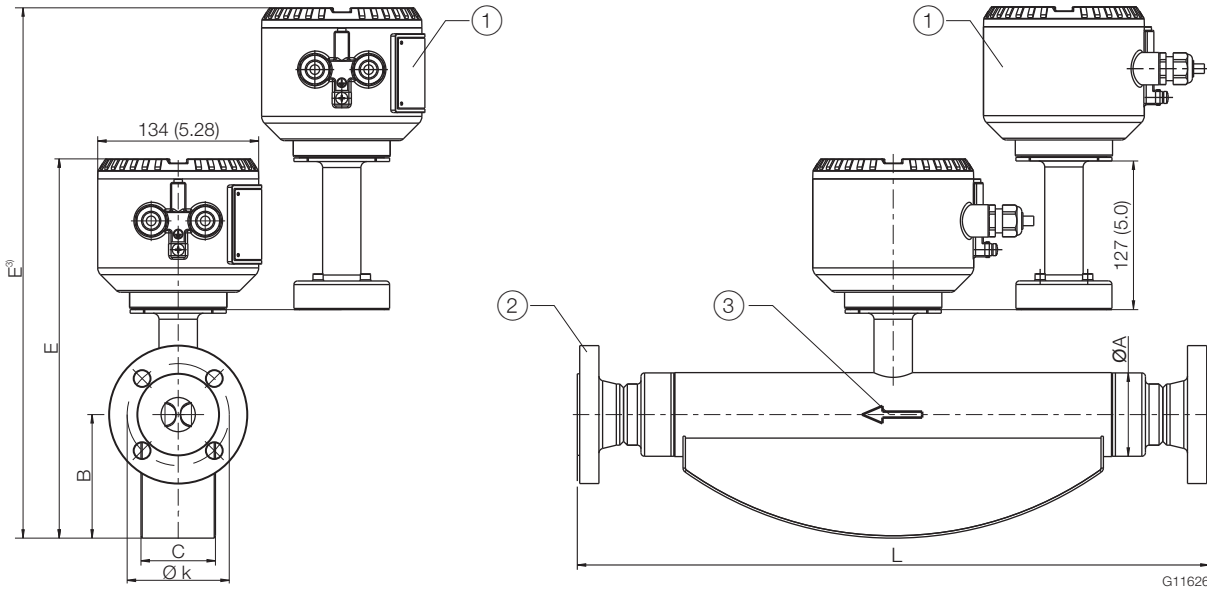

Fig. 22
 ① Option "extended tower length or option "pressure rating of the pressure sensor housing" ② Flange in accordance with EN 1092-1, ASME B16.5, ISO 7005 (connection dimensions for ASME flanges acc. to ASME B16.5 (ANSI)) ③ Flow direction

Meter tube nominal diameter DN 15 (1/2")								Approx. weight	
DN / process connection		L	Ø k	Ø A	B	C	E	Aluminum ¹⁾	Stainless steel ²⁾
10 (3/8)	PN 40 (EN 1092-1 B1)	385 (15.2)	60 (2.4)	44.5 (1.8)	77 (3.0)	46 (1.8)	278 / 405 ³⁾ (10.9 / 15.9 ³⁾)	9 / 10 ³⁾ (19.8 / 22 ³⁾)	12 / 13 ³⁾ (26.5 / 28.7 ³⁾)
	JIS 10K	385 (15.2)	65 (2.6)						
15 (1/2)	PN 40 (EN 1092-1 B1)	385 (15.2)	65 (2.6)						
	PN 63 (EN 1092-1 B2)	403 (15.9)	75 (3.0)						
	PN 100 (EN 1092-1 B2)								
	CL150 (ASME B16.5)	435 (17.1)	60.5 (2.4)						
	CL300 (ASME B16.5)	421 (16.6)	66.7 (2.6)						
	CL600 (ASME B16.5)								
	CL900 (ASME B16.5)	421 (16.6)	82.6 (3.3)						
JIS 10K	385 (15.2)	70 (2.8)							
20 (3/4)	PN 40 (EN 1092-1 B1)	421 (16.6)	75 (3.0)						
	CL150 (ASME B16.5)	421 (16.6)	69.9 (2.8)						
	JIS 10K	421 (16.6)	75 (3.0)						

Meter tube nominal diameter DN 25 (1")								Approx. weight	
DN / process connection		L	Ø k	Ø A	B	C	E	Aluminum ¹⁾	Stainless steel ²⁾
20 (3/4)	PN 40 (EN 1092-1 B1)	576 (22.7)	75 (3.0)	69.5 (2.74)	103 (4.06)	62 (2.44)	317 / 444 ³⁾ (12.5 / 17.5 ³⁾)	11 / 12 ³⁾ (24,3 / 26.5 ³⁾)	14 / 15 ³⁾ (30.9 / 33.1 ³⁾)
	CL150 (ASME B16.5)	575 (22.6)	69.9 (2.8)						
	JIS 10K	576 (22.7)	75 (3.0)						
25 (1)	PN 40 (EN 1092-1 B1)	525 (20.7)	85 (3.3)						
	PN 63 (EN 1092-1 B2)	564 (22.2)	100 (3.9)						
	PN 100 (EN 1092-1 B2)								
	CL150 (ASME B16.5)	575 (22.6)	79.2 (3.1)						
	CL300 (ASME B16.5)	576 (22.7)	88.9 (3.5)						
	CL600 (ASME B16.5)								
	CL900 (ASME B16.5)	576 (22.7)	82.6 (3.25)						
	CL1500 (ASME B16.5)								
JIS 10K	525 (20.7)	90 (3.54)							
40 (1 1/2)	PN 40 (EN 1092-1 B1)	576 (22.7)	110 (4.33)						
	PN 63 (EN 1092-1 B2)	572 (22.5)	125 (4.92)						
	PN 100 (EN 1092-1 B2)								
	CL150 (ASME B16.5)	576 (22.7)	98.6 (3.88)						
	CL300 (ASME B16.5)	576 (22.7)	114.3 (45.0)						
	CL600 (ASME B16.5)								
	JIS 10K	576 (22.7)	105 (4.13)						

1) Devices with terminal boxes made from aluminum.

2) Devices with terminal boxes made from stainless steel.

3) Devices with option "extended tower length" or option "pressure rating of the pressure sensor housing".

Tolerance for dimension L: +0 / -3 mm (+0 / -0.018 inch)

CoriolisMaster FCB430, FCB450, FCH430, FCH450

Coriolis mass flowmeter

Meter tube nominal diameter DN 50 (2")								Approx. weight	
DN / process connection		L	Ø k	Ø A	B	C	E	Aluminum ¹⁾	Stainless steel ²⁾
40 (1 1/2)	PN 40 (EN 1092-1 B1)	763 (30)	110 (4.33)	99 (3.9)	125 (4.92)	80 (3.15)	354 / 481 ³⁾ (13.94 / 18.94 ³⁾)	27 / 28 ³⁾ (59,5 / 61,7 ³⁾)	30 / 31 ³⁾ (66,1 / 68,3 ³⁾)
	PN 63 (EN 1092-1 B2)	745 (29.33)	125 (4.92)						
	PN 100 (EN 1092-1 B2)								
	CL150 (ASME B16.5)	763 (30)	98.6 (3.88)						
	CL300 (ASME B16.5)	756 (29.76)	114.3 (4.5)						
	CL600 (ASME B16.5)								
	CL900 (ASME B16.5)	780 (30.71)	124 (4.88)						
	CL1500 (ASME B16.5)								
JIS 10K	763 (30)	105 (4.13)							
50 (2)	PN 40 (EN 1092-1 B1)	715 (28.15)	125 (4.92)						
	PN 63 (EN 1092-1 B2)	745 (29.3)	135 (5.31)						
	PN 100 (EN 1092-1 B2)	745 (29.3)	145 (5.71)						
	CL150 (ASME B16.5)	715 (28.15)	120.7 (4.75)						
	CL300 (ASME B16.5)	763 (30)	127 (5.0)						
	CL600 (ASME B16.5)	773 (30.43)	127 (5.0)						
	CL900 (ASME B16.5)	790 (31.1)	165.1 (6.5)						
	CL1500 (ASME B16.5)								
JIS 10K	715 (28.15)	120 (4.72)							
65 (2 1/2)	PN 40 (EN 1092-1 B1)	763 (30)	145 (5.71)						
	CL150 (ASME B16.5)	756 (29.8)	139.7 (5.5)						
	CL900 (ASME B16.5)	800 (31.5)	190.5 (7.5)						
	CL1500 (ASME B16.5)								
	JIS 10K	763 (30)	140 (5.51)						

1) Devices with terminal boxes made from aluminum.

2) Devices with terminal boxes made from stainless steel.

3) Devices with option "extended tower length" or option "pressure rating of the pressure sensor housing".

Tolerance for dimension L: +0 / -3 mm (+0 / -0.018 inch)

Devices with meter tube nominal diameter DN 80 and flange DN 65 ... 100

Sensor with wetted parts made from stainless steel. All specified dimensions and weights are in mm (inch) or kg (lb).

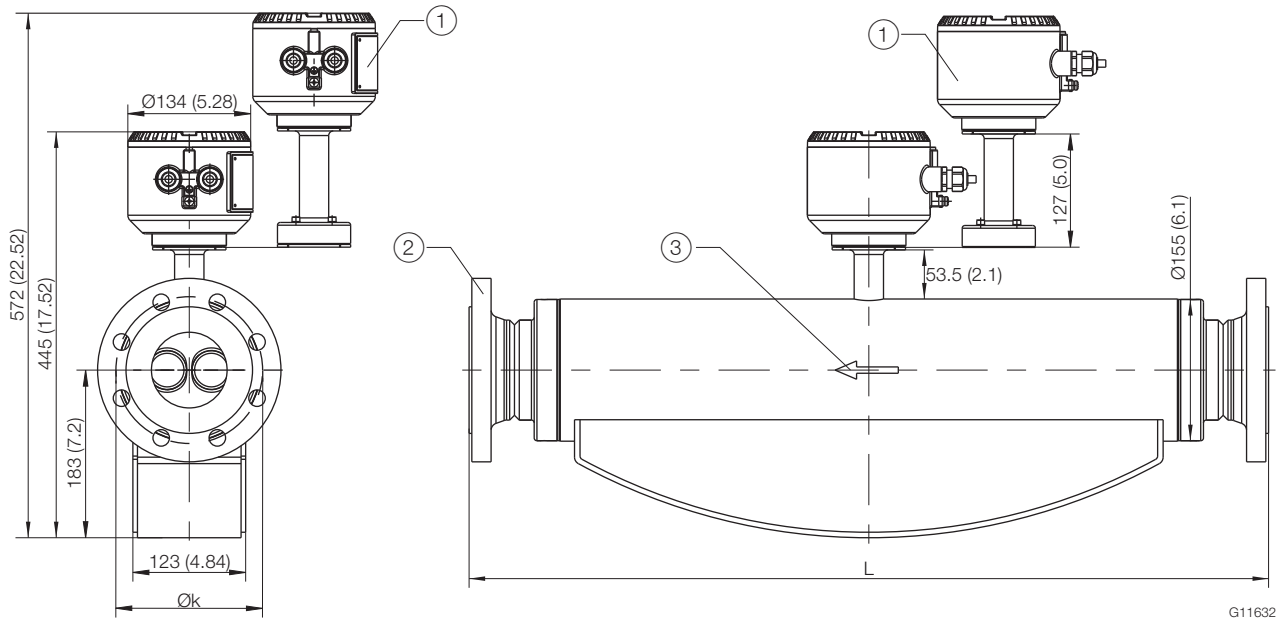

Fig. 23

① Option "extended tower length or option "pressure rating of the pressure sensor housing" ② Flange in accordance with EN 1092-1, ASME B16.5, ISO 7005 (connection dimensions for ASME flanges acc. to ASME B16.5 (ANSI)) ③ Flow direction

Meter tube nominal diameter DN 80 (3")			Approx. weight		
DN / process connection	L	Ø k	Aluminum ¹⁾	Stainless steel ²⁾	
65	PN 16 (EN 1092-1 B1)	— ⁴⁾	— ⁴⁾	— ⁴⁾	
(2 1/2")	PN 40 (EN 1092-1 B1)	910 (35.83)	70 / 71 ³⁾ (154.3 / 156.5 ³⁾)	73 / 74 ³⁾ (160.9 / 163.1 ³⁾)	
	PN 63 (EN 1092-1 B2)		74 / 75 ³⁾ (163.1 / 165.4 ³⁾)	77 / 78 ³⁾ (169.8 / 172.0 ³⁾)	
	PN 100 (EN 1092-1 B2)		78 / 79 ³⁾ (172 / 174.2 ³⁾)	81 / 82 ³⁾ (178.6 / 180.8 ³⁾)	
	CL150 (ASME B16.5)	— ⁴⁾	— ⁴⁾	— ⁴⁾	
	CL300 (ASME B16.5)	920 (36.22)	149.4 (5.88)	72 / 73 ³⁾ (158.7 / 160.9 ³⁾)	75 / 76 ³⁾ (163.1 / 167.6 ³⁾)
	CL600 (ASME B16.5)			73 / 74 ³⁾ (160.9 / 163.1 ³⁾)	76 / 77 ³⁾ (167.6 / 169.8 ³⁾)
	CL900 (ASME B16.5)	965 (37.99)	190.5 (7.5)	90 / 91 ³⁾ (198.4 / 200.6 ³⁾)	93 / 94 ³⁾ (205.3 / 207.23 ³⁾)
	CL1500 (ASME B16.5)				
JIS 10K	910 (35.83)	140 (5.5)	70 / 71 ³⁾ (154.3 / 156.5 ³⁾)	73 / 74 ³⁾ (160.9 / 163.1 ³⁾)	

1) Devices with terminal boxes made from aluminum.

2) Devices with terminal boxes made from stainless steel.

3) Devices with option "extended tower length" or option "pressure rating of the pressure sensor housing".

4) On request

Tolerance for dimension L: +0 / -3 mm (+0 / -0.018 inch)

CoriolisMaster FCB430, FCB450, FCH430, FCH450

Coriolis mass flowmeter

Meter tube nominal diameter DN 80 (3")				Approx. weight	
DN / process connection	L	Ø k	Aluminum ¹⁾	Stainless steel ²⁾	
80 (3")	PN 16 (EN 1092-1 B1)	870 (34.25)	160 (6.30)	70 / 71 ³⁾ (154.3 / 156.5 ³⁾)	
	PN 40 (EN 1092-1 B1)			73 / 74 ³⁾ (160.9 / 163.1 ³⁾)	
	PN 63 (EN 1092-1 B2)	910 (35.83)	170 (6.69)	71 / 72 ³⁾ (156.5 / 158.7 ³⁾)	
	PN 100 (EN 1092-1 B2)			74 / 75 ³⁾ (163.1 / 165.4 ³⁾)	
	CL150 (ASME B16.5)	880 (34.65)	152.4 (6.00)	75 / 76 ³⁾ (163.1 / 167.6 ³⁾)	
	CL300 (ASME B16.5)	895 (35.24)	168.1 (6.62)	78 / 79 ³⁾ (172.0 / 174.2 ³⁾)	
	CL600 (ASME B16.5)	920 (36.22)		81 / 82 ³⁾ (178.6 / 180.8 ³⁾)	
	CL900 (ASME B16.5)	1100 (43.31)	190.5 (7.50)	77 / 78 ³⁾ (169.8 / 172.0 ³⁾)	
	CL1500 (ASME B16.5)	1300 (51.18)	203.2 (8.00)	84 / 85 ³⁾ (185.2 / 187.4 ³⁾)	
	JIS 10K	870 (34.25)	150 (5.91)	90 / 91 ³⁾ (198.4 / 200.6 ³⁾)	
100 (4")	PN 16 (EN 1092-1 B1)	875 (34.45)	180 (7.09)	71 / 72 ³⁾ (156.5 / 158.7 ³⁾)	
	PN 40 (EN 1092-1 B1)			74 / 75 ³⁾ (163.1 / 165.3 ³⁾)	
	PN 63 (EN 1092-1 B2)	1060 (41.73)	200 (7.87)	72 / 73 ³⁾ (158.7 / 160.94 ³⁾)	
	PN 100 (EN 1092-1 B2)	1080 (42.52)	210 (8.27)	75 / 76 ³⁾ (165.4 / 167.55 ³⁾)	
	CL150 (ASME B16.5)	880 (34.65)	190.5 (7.50)	82 / 83 ³⁾ (180.8 / 183.0 ³⁾)	
	CL300 (ASME B16.5)	1075 (42.32)	200.2 (7.88)	85 / 86 ³⁾ (187.4 / 189.6 ³⁾)	
	CL600 (ASME B16.5)	1100 (43.31)	215.9 (8.50)	90 / 91 ³⁾ (198.4 / 200.6 ³⁾)	
	CL900 (ASME B16.5)	1130 (44.49)	234.9 (9.25)	93 / 94 ³⁾ (205.3 / 207.23 ³⁾)	
	CL1500 (ASME B16.5)	1150 (45.28)	241.3 (9.50)	76 / 77 ³⁾ (167.6 / 169.8 ³⁾)	
	JIS 10K	1060 (41.7)	175 (6.9)	87 / 88 ³⁾ (191.8 / 194.0 ³⁾)	

1) Devices with terminal boxes made from aluminum.

2) Devices with terminal boxes made from stainless steel.

3) Devices with option "extended tower length" or option "pressure rating of the pressure sensor housing".

4) On request

Tolerance for dimension L: +0 / -3 mm (+0 / -0.018 inch)

Devices with meter tube nominal diameter DN 100 and flange DN 80 ... 100

Sensor with wetted parts made from stainless steel. All specified dimensions and weights are in mm (inch) or kg (lb).

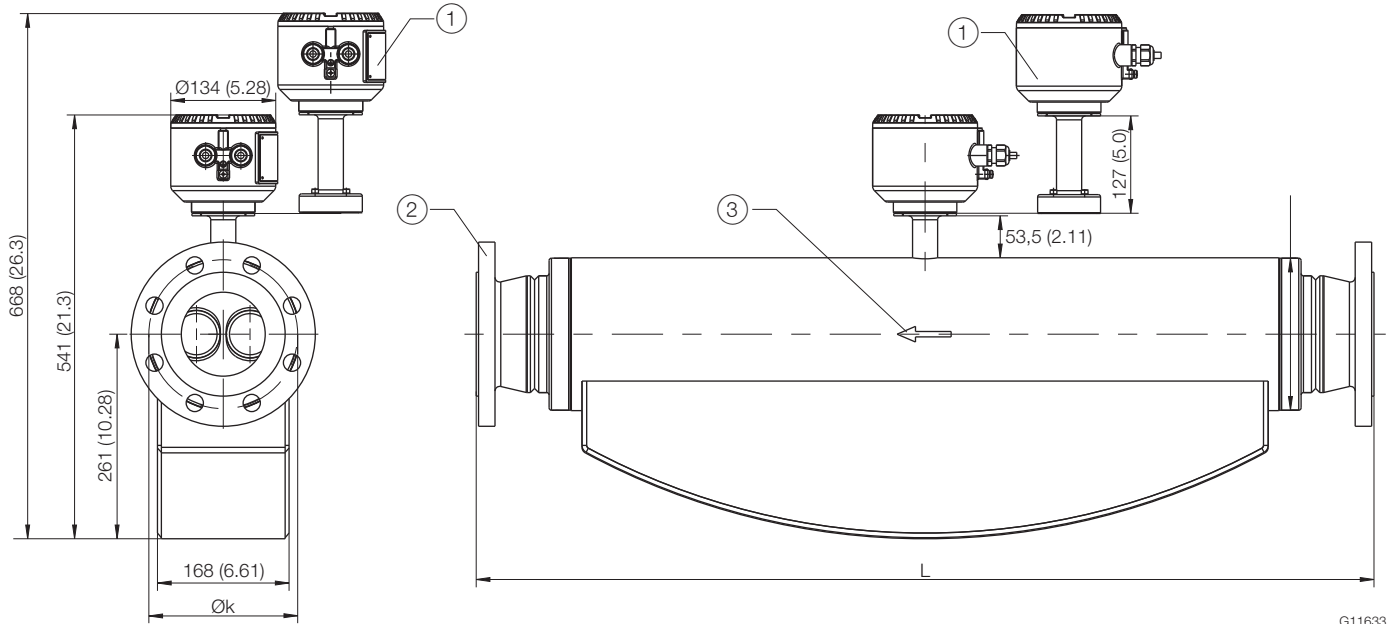

G11633

Fig. 24

① Option "extended tower length or option "pressure rating of the pressure sensor housing" ② Flange in accordance with EN 1092-1, ASME B16.5, ISO 7005 (connection dimensions for ASME flanges acc. to ASME B16.5 (ANSI)) ③ Flow direction

Meter tube nominal diameter DN 100 (4")			Approx. weight		
DN / process connection	L	Ø k	Aluminum ¹⁾	Stainless steel ²⁾	
80 (3")	PN 16 (EN 1092-1 B1)	1222 (48.11)	122 / 123 ³⁾ (269 / 271 ³⁾)	124 / 126 ³⁾ (273 / 278 ³⁾)	
	PN 40 (EN 1092-1 B1)				123 / 124 ³⁾ (271 / 273 ³⁾)
	PN 63 (EN 1092-1 B2)	1234 (48.58)	127 / 128 ³⁾ (280 / 282 ³⁾)	129 / 130 ³⁾ (284 / 287 ³⁾)	
	PN 100 (EN 1092-1 B2)		129 / 130 ³⁾ (284 / 287 ³⁾)	131 / 132 ³⁾ (289 / 291 ³⁾)	
	CL150 (ASME B16.5)	1244 (48.98)	124 / 125 ³⁾ (273 / 276 ³⁾)	126 / 127 ³⁾ (278 / 280 ³⁾)	
	CL300 (ASME B16.5)		132 / 133 ³⁾ (291 / 293 ³⁾)	134 / 135 ³⁾ (295 / 298 ³⁾)	
	CL600 (ASME B16.5)		135 / 136 ³⁾ (298 / 300 ³⁾)	137 / 138 ³⁾ (302 / 304 ³⁾)	
	CL900 (ASME B16.5)	1470 (57.87)	190.5 (7.50)	138 / 139 ³⁾ (304 / 306 ³⁾)	140 / 141 ³⁾ (307 / 311 ³⁾)
	CL1500 (ASME B16.5)	1500 (59.05)	203.2 (8.00)	150 / 151 ³⁾ (331 / 335 ³⁾)	152 / 153 ³⁾ (355 / 337 ³⁾)
JIS 10K	1275 (50.20)	150 (5.91)	119 / 120 ³⁾ (262 / 265 ³⁾)	122 / 123 ³⁾ (269 / 271 ³⁾)	

CoriolisMaster FCB430, FCB450, FCH430, FCH450

Coriolis mass flowmeter

Meter tube nominal diameter DN 100 (4")			Approx. weight		
DN / process connection	L	Ø k	Aluminum ¹⁾	Stainless steel ²⁾	
100 (4")	PN 16 (EN 1092-1 B1)	1122 (44.17)	180 (7.09)	119 / 120 ³⁾ (262 / 265 ³⁾)	122 / 123 ³⁾ (269 / 271 ³⁾)
	PN 40 (EN 1092-1 B1)	1144 (45.04)	190 (7.48)	122 / 123 ³⁾ (269 / 271 ³⁾)	125 / 126 ³⁾ (276 / 278 ³⁾)
	PN 63 (EN 1092-1 B2)	1304 (51.34)	138 (5.43)	129 / 130 ³⁾ (248 / 287 ³⁾)	132 / 133 ³⁾ (291 / 293 ³⁾)
	PN 100 (EN 1092-1 B2)	1334 (52.52)	150 (5.91)	137 / 138 ³⁾ (302 / 304 ³⁾)	140 / 141 ³⁾ (309 / 311 ³⁾)
	CL150 (ASME B16.5)	1144 (45.04)	190.5 (7.50)	123 / 124 ³⁾ (271 / 273 ³⁾)	126 / 127 ³⁾ (278 / 280 ³⁾)
	CL300 (ASME B16.5)	1324 (52.13)	200.2 (7.88)	135 / 136 ³⁾ (298 / 300 ³⁾)	138 / 139 ³⁾ (304 / 306 ³⁾)
	CL600 (ASME B16.5)	1354 (53.31)	215.9 (8.50)	137 / 138 ³⁾ (302 / 304 ³⁾)	140 / 141 ³⁾ (309 / 311 ³⁾)
	CL900 (ASME B16.5)	1380 (54.33)	234.9 (9.25)	157 / 158 ³⁾ (346 / 348 ³⁾)	159 / 160 (350 / 353 ³⁾)
	CL1500 (ASME B16.5)	1400 (55.12)	241.3 (9.50)	171 / 172 ³⁾ (377 / 379 ³⁾)	173 / 174 ³⁾ (381 / 384 ³⁾)
	JIS 10K	1150 (45.28)	175 (6.89)	122 / 123 ³⁾ (269 / 271 ³⁾)	125 / 126 ³⁾ (276 / 278 ³⁾)
150 (6")	PN 16 (EN 1092-1 B1)	1260 (49.61)	240 (9.44)	128 / 129 ³⁾ (282 / 284 ³⁾)	130 / 131 ³⁾ (287 / 289 ³⁾)
	PN 40 (EN 1092-1 B1)		250 (9.84)	136 / 137 ³⁾ (300 / 302 ³⁾)	138 / 139 ³⁾ (304 / 306 ³⁾)
	CL150 (ASME B16.5)	1330 (52.36)	241,3 (9.50)	133 / 134 ³⁾ (293 / 295 ³⁾)	136 / 137 ³⁾ (300 / 302 ³⁾)
	JIS 10K	1275 (50.20)	240 (9.44)	126 / 127 ³⁾ (278 / 280 ³⁾)	129 / 130 ³⁾ (284 / 287 ³⁾)

1) Devices with terminal boxes made from aluminum.

2) Devices with terminal boxes made from stainless steel.

3) Devices with option "extended tower length" or option "pressure rating of the pressure sensor housing".

Tolerance for dimension L: +0 / -3 mm (+0 / -0.018 inch)

Devices with meter tube nominal diameter DN 150 and flange DN 100 ... 200

Sensor with wetted parts made from stainless steel. All specified dimensions and weights are in mm (inch) or kg (lb).

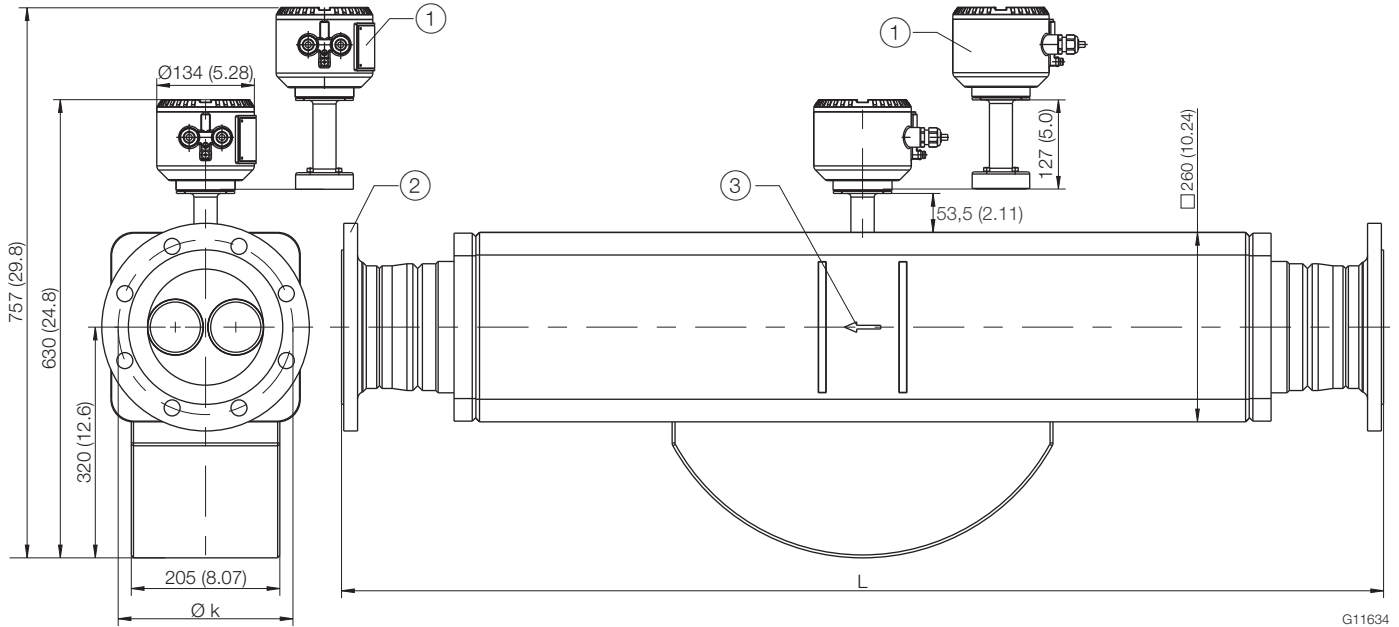

Fig. 25

① Option "extended tower length or option "pressure rating of the pressure sensor housing" ② Flange in accordance with EN 1092-1, ASME B16.5, ISO 7005 (connection dimensions for ASME flanges acc. to ASME B16.5 (ANSI)) ③ Flow direction

Meter tube nominal diameter DN 150 (6")			Approx. weight	
DN / process connection	L	Ø k	Aluminum ¹⁾	Stainless steel ²⁾
100 (4")	PN 16 (EN 1092-1 B1)	1569 (61.77)	171 / 172 ³⁾ (377 / 379 ³⁾)	174 / 175 ³⁾ (384 / 386 ³⁾)
	PN 40 (EN 1092-1 B1)	1599 (62.95)	175 / 176 ³⁾ (386 / 388 ³⁾)	178 / 179 ³⁾ (392 / 395 ³⁾)

1) Devices with transmitter housing made from aluminum.

2) Devices with transmitter housing made from stainless steel.

3) Devices with option "extended tower length" or option "pressure rating of the pressure sensor housing".

Tolerance for dimension L: +0 / -5 mm (+0 / -0.2 inch)

CoriolisMaster FCB430, FCB450, FCH430, FCH450

Coriolis mass flowmeter

Meter tube nominal diameter DN 150 (6")				Approx. weight	
DN / process connection	L	Ø k	Aluminum ¹⁾	Stainless steel ²⁾	
150 (6")	PN 16 (EN 1092-1 B1)	1421 (55.94)	240 (9.45)	174 / 175 ³⁾ (384 / 386 ³⁾)	
	PN 40 (EN 1092-1 B1)	1461 (57.52)	250 (9.84)	182 / 183 ³⁾ (401 / 403 ³⁾)	
	CL150 (ASME B16.5)	1485 (58.46)	241.3 (9.50)	181 / 182 ³⁾ (399 / 401 ³⁾)	
	CL300 (ASME B16.5)	1505 (59.25)	269.7 (10.62)	199 / 200 ³⁾ (439 / 441 ³⁾)	
	CL600 (ASME B16.5)	1555 (61.22)	292.1 (11.50)	221 / 222 ³⁾ (487 / 489 ³⁾)	
	CL900 (ASME B16.5)	1605 (63.19)	317.5 (12.5)	245 / 246 ³⁾ (540 / 542 ³⁾)	
	CL1500 (ASME B16.5)	1665 (65.55)		287 / 288 ³⁾ (633 / 635 ³⁾)	
200 (8")	PN 40 (EN 1092-1 B1)	1637 (64.45)	320 (12.6)	206 / 207 ³⁾ (454 / 456 ³⁾)	
	CL150 (ASME B16.5)	1650 (64.96)	298.5 (11.75)	201 / 202 ³⁾ (443 / 445 ³⁾)	
	CL300 (ASME B16.5)	1670 (65.75)	330.2 (13.0)	225 / 226 ³⁾ (496 / 498 ³⁾)	

1) Devices with transmitter housing made from aluminum.

2) Devices with transmitter housing made from stainless steel.

3) Devices with option TE1 "extended tower length" or option PR4 / PR5 / PR6 / PR7 "pressure-resistant sensor housing".

Tolerance for dimension L: +0 / -5 mm (+0 / -0.2 inch)

Devices DN 15 ... 150 in NAMUR standard installation lengths (order option S5, S7)

Sensor with wetted parts made from stainless steel. All specified dimensions and weights are in mm (inch) or kg (lb).

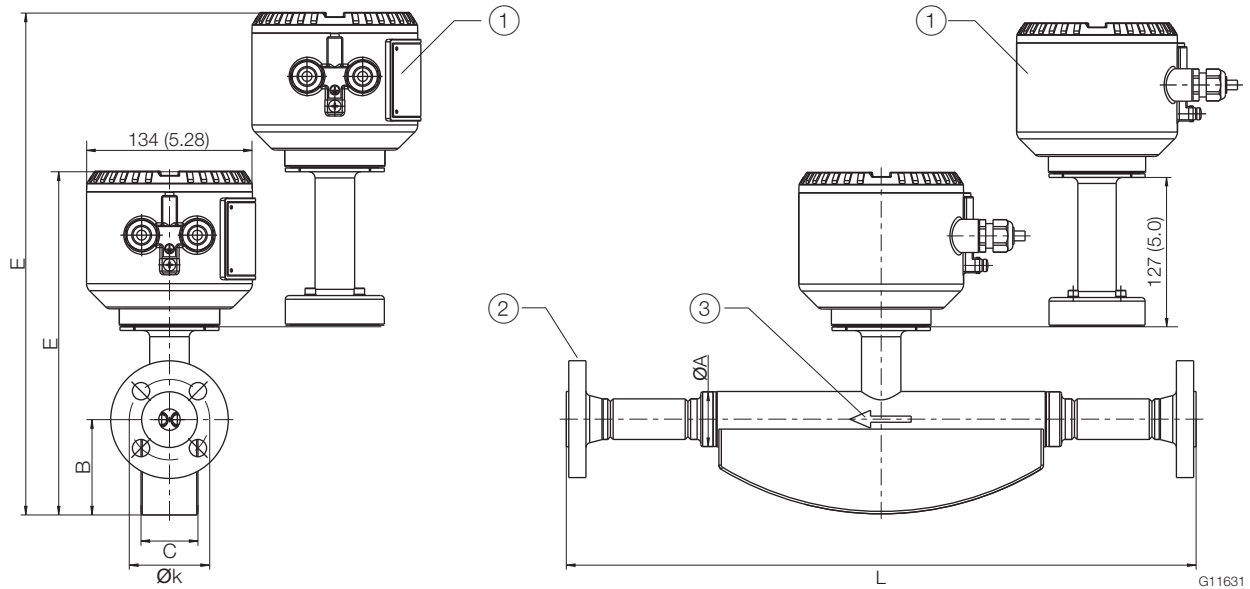

Fig. 26

- ① Option "extended tower length" or option "pressure rating of the pressure sensor housing" ② Flange in accordance with EN 1092-1
 ③ Flow direction

Devices DN 15 ... 150 in NAMUR standard installation lengths

Meter tube	Process connection EN 1092-1 B1	L	Ø k	Ø A	B	C	E	Approx. weight	
								Aluminum ¹⁾	Stainless steel ²⁾
DN 15 (1/2")	DN 15 (1/2") / PN 40	510 (20,08)	60 (2,4)	44,5 (1,8)	77 (3,0)	46 (1,8)	278 / 405 ³⁾ (10,9 / 15,9 ³⁾)	9,5 / 10,5 ³⁾ (20,9 / 23,2 ³⁾)	12,5 / 13,5 ³⁾ (27,6 / 29,8 ³⁾)
DN 25 (1")	DN 25 (1") / PN 40	600 (23,62)	75 (3,0)	69,5 (2,74)	103 (4,06)	62 (2,44)	317 / 444 ³⁾ (12,5 / 17,5 ³⁾)	11 / 12 ³⁾ (24,3 / 26,53)	14 / 15 ³⁾ (30,9 / 33,1 ³⁾)
DN 50 (1")	DN 50 (1") / PN 40	715 (28,15)	125 (4,92)	99 (3,9)	125 (4,92)	80 (3,15)	354 / 481 ³⁾ (13,94 / 18,94 ³⁾)	27 / 28 ³⁾ (59,5 / 61,7 ³⁾)	30 / 31 ³⁾ (66,1 / 68,3 ³⁾)
DN 80 (3")	DN 80 (3") / PN 40	915 (36,02)	160 (6,30)	155 (6,1)	183 (7,2)	123 (4,84)	445 / 572 ³⁾ (17,52 / 22,52 ³⁾)	70 / 71 ³⁾ (154 / 157 ³⁾)	73 / 74 ³⁾ (161 / 163 ³⁾)
DN 100 (4")	DN 100 (4") / PN 16	1400 (55,12)	180 (7,09)	195 (7,68)	261 (10,28)	168 (6,61)	541 / 668 ³⁾ (21,3 / 26,3 ³⁾)	119 / 120 ³⁾ (262 / 265 ³⁾)	122 / 123 ³⁾ (269 / 271 ³⁾)
DN 150 (6")	DN 150 (6") / PN 16	1700 (66,93)	240 (9,45)	260 (10,24)	320 (12,6)	205 (8,07)	630 / 757 ³⁾ (24,8 / 29,8 ³⁾)	174 / 175 ³⁾ (384 / 386 ³⁾)	177 / 178 ³⁾ (390 / 392 ³⁾)

1) Devices with terminal boxes made from aluminum.

2) Devices with terminal boxes made from stainless steel.

3) Devices with option "extended tower length" or option "pressure rating of the pressure sensor housing".

Tolerance for dimension L: +0 / -3 mm (+0 / -0.018 inch)

CoriolisMaster FCB430, FCB450, FCH430, FCH450

Coriolis mass flowmeter

Devices with meter tube nominal diameter DN 15 ... 80 and connections in accordance with SMS 1145, DIN 11851, DIN 32676, DIN ISO 228, ASME BPE and ASME B 1.20.1

Sensor with wetted parts made from stainless steel. All specified dimensions and weights are in mm (inch) or kg (lb).

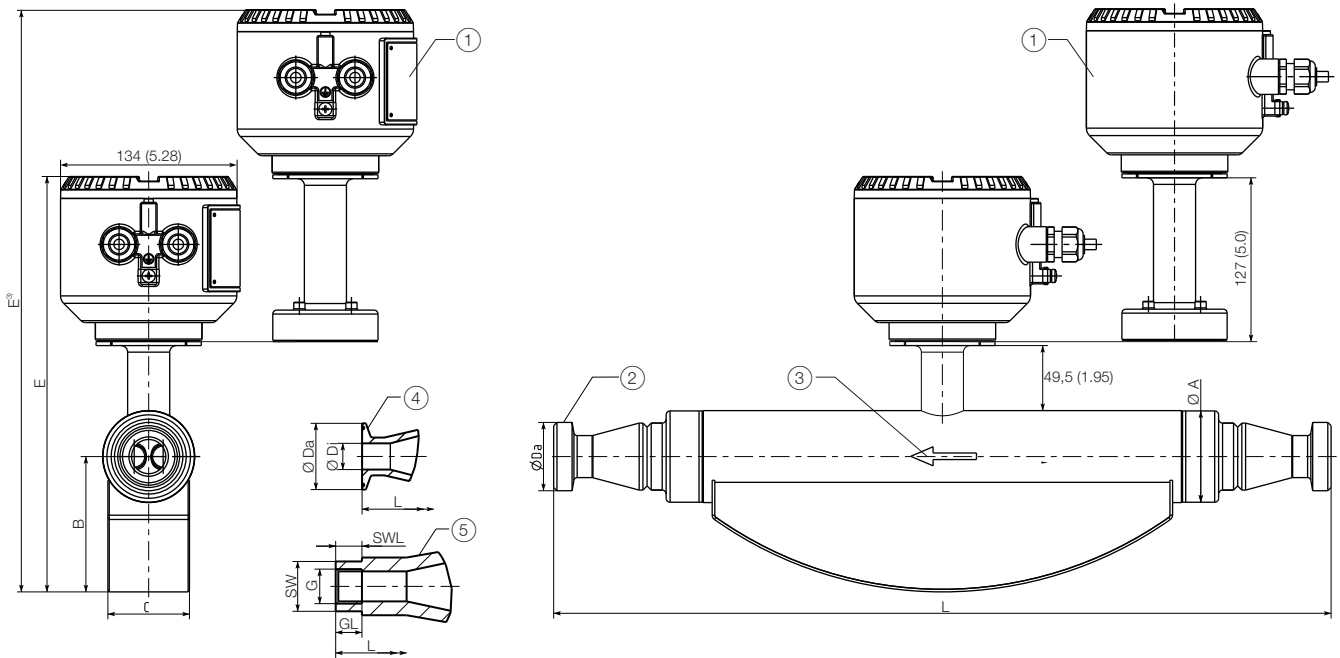

G11635

Fig. 27

① Option "extended tower length or option "pressure-resistant sensor housing" ② threaded spud in accordance with DIN 11851 and SMS 1145 ③ Flow direction ④ Clamping connection in accordance with DIN 32676 and ASME BPE ⑤ Female thread connection in accordance with DIN ISO 228 and ASME B 1.20.1

Process connection in accordance with SMS 1145 meter tube nominal diameter DN 25 ... 80 (1" ... 3")												
Meter tube DN	Process connection		L	Ø DA	Ø Di	Ø A	B	C	E	Approx. weight		
	DN	PN								Aluminum ¹⁾	Stainless steel ²⁾	
25 (1")	25 (1")	6	590 (23.2)	RD 40x1/6"	22.6 (0.89)	69.5 (2.74)	103 (4.06)	62 (2.44)	317 / 444 ³⁾ (12.48 / 17.48 ³⁾)	11 / 12 ³⁾	14 / 15 ³⁾	
	40 (1 1/2")			RD 60x1/6"						38 (1.50)	(24 / 27 ³⁾)	(31 / 33 ³⁾)
50 (2")	40 (1 1/2")	6	763 (30.0)	RD 60x1/6"	35.5 (1.40)	99 (3.46)	125 (4.92)	80 (3.15)	354 / 481 ³⁾ (13.94 / 18.94 ³⁾)	27 / 28 ³⁾	30 / 31 ³⁾	
	50 (2")			RD 70x1/6"						48.5 (1.91)	(60 / 62 ³⁾)	(66 / 68 ³⁾)
	65 (2 1/2")			RD 85x1/6"						60.5 (2.38)		
80 (3")	65 (2 1/2")	6	990 (39.0)	RD 85x1/6"	60.5 (2.38)	155 (6.10)	183 (7.20)	123 (4.84)	445 / 572 ³⁾ (17.52 / 22.52 ³⁾)	68 / 69 ³⁾	71 / 72 ³⁾	
	80 (3")		940 (37.0)	RD 98x1/4"						72.6 (2.86)	(150 / 152 ³⁾)	(157 / 159 ³⁾)

Process connection in accordance with DIN 11851 meter tube nominal diameter DN 15 ... 80 (1/2" ... 3")

Meter tube DN	Process connection		L	Ø DA	Ø Di	Ø A	B	C	E	Approx. weight					
	DN	PN								Aluminum ¹⁾	Stainless steel ²⁾				
15 (1/2")	10 (3/8")	40	413 (16.3)	RD 28x1/8"	10 (0.39)	44.5	77	46	278 / 405 ³⁾	9 / 10 ³⁾	12 / 13 ³⁾				
	15 (1/2")			RD 34x1/8"	16 (0.63)							(1.75)	(3.03)	(1.81)	(10.94 / 15.94 ³⁾)
	20 (3/4")			RD 44x1/6"	20 (0.79)										
25 (1")	20 (3/4")	40	590 (23.2)	RD 44x1/6"	20 (0.79)	69.5	103	62	317 / 444 ³⁾	11 / 12 ³⁾	14 / 15 ³⁾				
	25 (1")			RD 52x1/6"	26 (1.02)							(2.74)	(4.06)	(2.44)	(12.48 / 17.48 ³⁾)
	40 (1 1/2")			RD 65x1/6"	38 (1.5)										
50 (2")	40 (1 1/2")	25	763 (30.0)	RD 65x1/6"	38 (1.5)	99	125	80	354 / 481 ³⁾	27 / 28 ³⁾	30 / 31 ³⁾				
	50 (2")		740 (29.1)	RD 78x1/6"	50 (1.97)							(3.46)	(4.92)	(3.15)	(13.94 / 18.94 ³⁾)
	65 (2 1/2")			RD 95x1/6"	66 (2.6)										
80 (3")	65 (2 1/2")	25	990 (39.0)	RD 95x1/6"	66 (2.6)	155	183	123	445 / 572 ³⁾	68 / 69 ³⁾	71 / 72 ³⁾				
	80 (3")		940 (37.0)	RD 110x1/4"	81 (3.19)							(6.10)	(7.20)	(4.84)	(17.52 / 22.52 ³⁾)
	100 (4")			RD 130x1/4"	100 (3.94)										

Process connection in accordance with DIN 32676 meter tube nominal diameter DN 15 ... 80 (1/2" ... 3")

Meter tube DN	Process connection		L	Ø DA	Ø Di	Ø A	B	C	E	Approx. weight					
	DN	PN								Aluminum ¹⁾	Stainless steel ²⁾				
15 (1/2")	10 (3/8")	40	413 (16.3)	34 (1.34)	10 (0.39)	44.5	77	46	278 / 405 ³⁾	9 / 10 ³⁾	12 / 13 ³⁾				
	15 (1/2")				16 (0.63)							(1.75)	(3.03)	(1.81)	(10.94 / 15.94 ³⁾)
	20 (3/4")				20 (0.79)										
25 (1")	20 (3/4")	40	590 (23.2)	50.5 (1.99)	20 (0.79)	69.5	103	62	317 / 444 ³⁾	11 / 12 ³⁾	14 / 15 ³⁾				
	25 (1")				26 (1.02)							(2.74)	(4.06)	(2.44)	(12.48 / 17.48 ³⁾)
	40 (1 1/2")				38 (1.5)										
50 (2")	40 (1 1/2")	25	763 (30.0)	64 (2.52)	38 (1.5)	99	125	80	354 / 481 ³⁾	27 / 28 ³⁾	30 / 31 ³⁾				
	50 (2")		740 (29.1)		50 (1.97)							(3.46)	(4.92)	(3.15)	(13.94 / 18.94 ³⁾)
	65 (2 1/2")				91 (3.58)										
80 (3")	65 (2 1/2")	10	950 (37.4)	106 (4.17)	66 (2.6)	155	183	123	445 / 572 ³⁾	68 / 69 ³⁾	71 / 72 ³⁾				
	80 (3")		910 (35.83)		81 (3.19)							(6.10)	(7.20)	(4.84)	(17.52 / 22.52 ³⁾)
	100 (4")				119 (4.69)										

1) Devices with terminal boxes made from aluminum.

2) Devices with terminal boxes made from stainless steel.

3) Devices with option "extended tower length" or option "pressure rating of the pressure sensor housing".

Tolerance for dimension L: +0 / -3 mm (+0 / -0.018 inch)

CoriolisMaster FCB430, FCB450, FCH430, FCH450

Coriolis mass flowmeter

Dimensions for sensors featuring meter tubes with nominal diameter DN 15 ... 80 (1/2" ... 3") and process connection in accordance with ASME BPE

Meter tube DN	Process connection DN	PN	L	Ø DA	Ø Di	Ø A	B	C	E	Approx. weight	
										Aluminum ¹⁾	Stainless steel ²⁾
15 (1/2")	3/8"-Type A	10	—	—	—	44.5 (1.75)	77 (3.03)	46 (1.81)	278 / 405 ³⁾ (10.94 / 15.94 ³⁾)	9 / 10 ³⁾ (20 / 22 ³⁾)	12 / 13 ³⁾ (27 / 29 ³⁾)
	1/2"-Type A		433 (17.05)	25 (0.98)	9.4 (0.37)						
	3/4"-Type A		—	—	—						
25 (1")	3/4"-Type A	10	—	—	—	69.5 (2.74)	103 (4.06)	62 (2.44)	317 / 444 ³⁾ (12.48 / 17.48 ³⁾)	11 / 12 ³⁾ (24 / 27 ³⁾)	14 / 15 ³⁾ (31 / 33 ³⁾)
	1"-Type B		590 (23.23)	50.4 (1.98)	22.1 (0.87)						
	1 1/2"-Type B		590 (23.23)	50.4 (1.98)	34.8 (1.37)						
50 (2")	1 1/2"-Type B	10	—	—	—	99 (3.46)	125 (4.92)	80 (3.15)	354 / 481 ³⁾ (13.94 / 18.94 ³⁾)	27 / 28 ³⁾ (60 / 62 ³⁾)	30 / 31 ³⁾ (66 / 68 ³⁾)
	2"-Type B		740 (29.13)	63.9 (2.52)	47.5 (1.87)						
	2 1/2"-Type B		—	—	—						
80 (3")	2 1/2"-Type B	10	950 (37.40)	77.4 (3.05)	60.2 (2.37)	155 (6.10)	183 (7.20)	183 (7.20)	445 / 572 ³⁾ (17.52 / 22.52 ³⁾)	68 / 69 ³⁾ (150 / 152 ³⁾)	71 / 72 ³⁾ (157 / 159 ³⁾)
	3"-Type B		910 (35.83)	90.9 (3.19)	72.9 (2.87)						
	4"-Type B		910 (35.83)	118.9 (4.68)	97.4 (3.83)						

Process connection in accordance with DIN ISO 228 and ASME B 1.20.1, meter tube nominal diameter DN 15 ... 80 (1/2" ... 3")

Meter tube DN	Process connection DN / G	PN	L	GL ⁴⁾	WS ⁵⁾	SWL ⁵⁾	Ø A	B	C	E	Approx. weight	
											Aluminum ¹⁾	Stainless steel ²⁾
15 (1/2")	8 (1/4") / G 1/4"	100	450 (17.72)	10 (0.39)	19	10 (0.39)	44.5 (1.75)	77 (3.03)	46 (1.81)	278 / 405 ³⁾ (10.94 / 15.94 ³⁾)	9 / 10 ³⁾ (20 / 22 ³⁾)	12 / 13 ³⁾ (27 / 29 ³⁾)
	15 (1/2") / G 1/2"			13.5 (0.53)	27	15 (0.59)						
	25 (1") / G 1"			17 (0.67)	50	20 (0.79)						
	15 (1/2") / 1/2" NPT			15.6 (0.61)	27	15 (0.59)						

- 1) Devices with terminal boxes made from aluminum.
- 2) Devices with terminal boxes made from stainless steel.
- 3) Devices with option "extended tower length" or option "pressure rating of the pressure sensor housing".
- 4) Dimension GL: Provide thread length of female thread.
- 5) Dimension SW: Provide width across flats in mm, Dimension SWL: Provide length of wrench flats in mm.

Tolerance for dimension L: +0 / -3 mm (+0 / -0.018 inch)

Sensor with wetted parts made from C4 or C22 nickel alloy

For devices with wetted parts made from C4 or C22 nickel alloy, the installation length (L) is different from previous tables. All other dimensions and the weight are unchanged. All dimensions specified in mm (inch).

Dimensions for sensors with process connection in accordance with EN 1092-1 and ASME B16.5 (ANSI)									
Meter tube nominal diameter	Process connection	L							
		EN 1092-1 B1	EN 1092-1 B1	EN 1092-1 B2	EN 1092-1 B2	ASME CL			JIS 10K
		PN 16	PN 40	PN 63	PN 100	CL150	CL300	CL600	
DN 15 (1/2")	DN 10 (1/4")	—	449 (17.7)	449 (17.7)	449 (17.7)	—	—	—	449 (17.7)
	DN 15 (1/2")	—	442 (17.4)	442 (17.4)	442 (17.4)	442 (17.4)	442 (17.4)	442 (17.4)	442 (17.4)
	DN 20 (3/4")	—	428 (16.9)	428 (16.9)	428 (16.9)	428 (16.9)	428 (16.9)	428 (16.9)	428 (16.9)
DN 25 (1")	DN 20 (3/4")	—	646 (25.4)	646 (25.4)	646 (25.4)	646 (25.4)	646 (25.4)	646 (25.4)	646 (25.4)
	DN 25 (1")	—	614 (24.2)	614 (24.2)	614 (24.2)	614 (24.2)	614 (24.2)	614 (24.2)	614 (24.2)
	DN 40 (1 1/2")	—	576 (22.7)	576 (22.7)	576 (22.7)	576 (22.7)	576 (22.7)	576 (22.7)	576 (22.7)
DN 50 (2")	DN 40 (1 1/2")	—	814 (32.0)	814 (32.0)	814 (32.0)	814 (32.0)	814 (32.0)	814 (32.0)	814 (32.0)
	DN 50 (2")	—	764 (30.1)	764 (30.1)	764 (30.1)	764 (30.1)	764 (30.1)	764 (30.1)	764 (30.1)
	DN 65 (2 1/2")	—	819 (32.2)	819 (32.2)	819 (32.2)	792 (31.2)	792 (31.2)	792 (31.2)	819 (32.2)
DN 80 (3")	DN 65 (2 1/2")	—	1021 (40.2)	1021 (40.2)	1021 (40.2)	1021 (40.2)	1021 (40.2)	1021 (40.2)	1021 (40.2)
	DN 80 (3")	—	971 (38.2)	—	971 (38.2)	971 (38.2)	971 (38.2)	971 (38.2)	971 (38.2)
	DN 100 (4")	971 (38.2)	971 (38.2)	971 (38.2)	971 (38.2)	971 (38.2)	971 (38.2)	971 (38.2)	971 (38.2)
DN 100 (4")	DN 80 (3")	1357 (53.4)	1357 (53.4)	1357 (53.4)	1357 (53.4)	1357 (53.4)	1357 (53.4)	1357 (53.4)	1357 (53.4)
	DN 100 (4")	1280 (50.4)	1280 (50.4)	1280 (50.4)	1280 (50.4)	1280 (50.4)	1280 (50.4)	1280 (50.4)	1280 (50.4)
	DN 150 (6")	1261 (49.6)	1261 (49.6)	1261 (49.6)	1261 (49.6)	1261 (49.6)	1261 (49.6)	1261 (49.6)	1261 (49.6)
DN 150 (6")	DN 100 (4")	1592 (62.7)	1592 (62.7)	1632 (64.3)	1632 (64.3)	1592 (62.7)	1632 (64.3)	1632 (64.3)	1592 (62.7)
	DN 150 (6")	1502 (59.1)	1502 (59.1)	1542 (60.7)	1542 (60.7)	1502 (59.1)	1542 (60.7)	1542 (60.7)	1502 (59.1)

L dimension tolerance:

- Meter tube nominal diameter DN 15 ... 50 (1/2" ... 2"): +0 / -3 mm (+0 / -0.018 inch)
- Meter tube nominal diameter DN 80 (3"): +0 / -5 mm (+0 / -0.2 inch)
- Meter tube nominal diameter DN 100 ... 150 (4" ... 6"): +0 / -8 mm (+0 / -0.31 inch)

CoriolisMaster FCB430, FCB450, FCH430, FCH450

Coriolis mass flowmeter

Devices with single-compartment transmitter housing

In integral mount design devices, the height (E) and the dimensions provided in Fig. 28 differ from the dimensions of the devices with dual-compartment transmitter housings.

- To the height (E), 13 mm (0.51 inch) must be added.
- All other dimensions and the weight are unchanged.

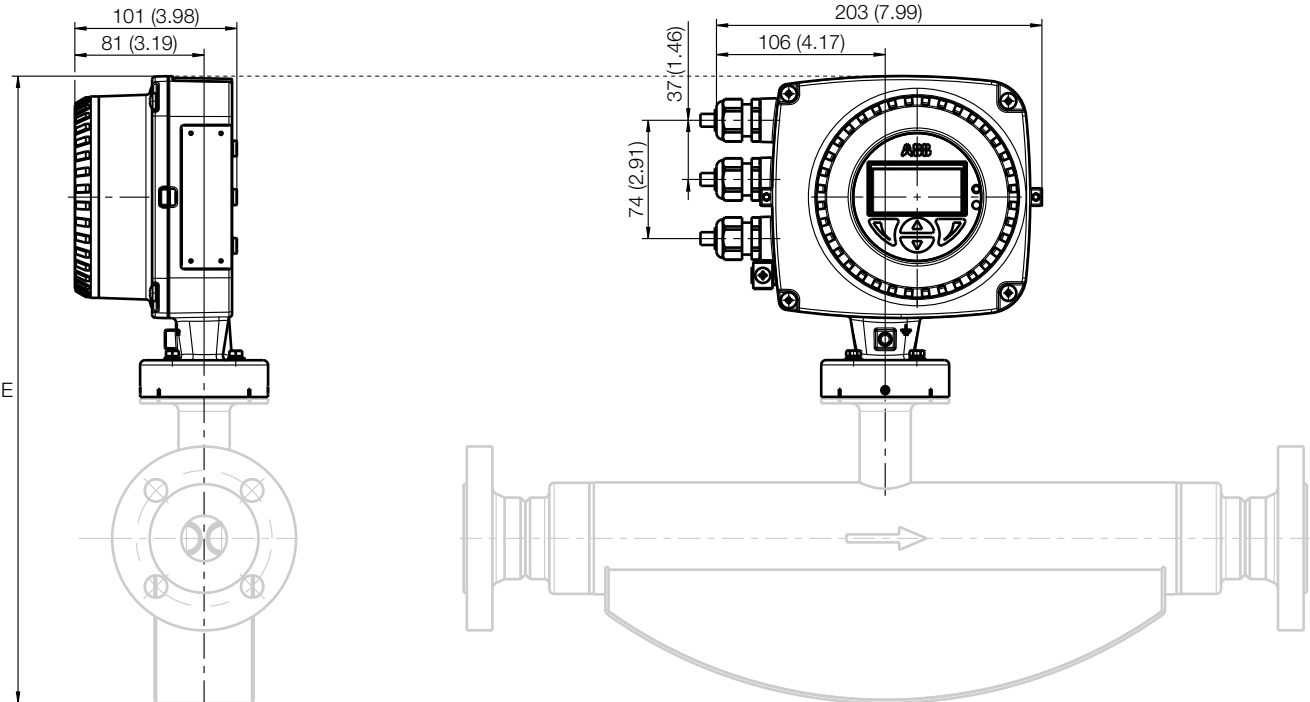

Fig. 28: Integral mount design with single-compartment transmitter housing

G11832

Ordering information

NOTICE

For dependancies and limitations please check the online Product Selection Assistant at www.abb.com/flow-selector.

Main ordering information CoriolisMaster FCB430, FCB450

Base model

CoriolisMaster FCB430 Coriolis Mass Flowmeter	FCB430	XX	XX	XXXXX	XX	XX	X	X	XX	XX	X
CoriolisMaster FCB450 Coriolis Mass Flowmeter	FCB450	XX	XX	XXXXX	XX	XX	X	X	XX	XX	X
Explosion Protection Certification											
General Purpose		Y0			Continued see next page						
ATEX / IECEx (Zone 2 / 22)		A2									
ATEX / IECEx (Zone 1 / 21)		A1									
cFMus version Class 1 Div. 2 (Zone 2 / 21)		F2									
cFMus version Class 1 Div. 1 (Zone 1 / 21)		F1									
Connection Design / Connection Box Material / Cable Glands											
Integral, defined by Transmitter housing		Y0									
Remote / Aluminium / 1 x M20 x 1.5		U1									
Remote / Aluminium / 1 x NPT 1/2 in.		U2									
Remote / Stainless Steel / 1 x M20 x 1.5		A1									
Remote / Stainless Steel / 1 x NPT 1/2 in.		A2									
Meter Size / Connection Size											
DN 15 (1/2 in.) / DN 10 (3/8 in.)				015E1							
DN 15 (1/2 in.) / DN 15 (1/2 in.)				015R0							
DN 15 (1/2 in.) / DN 20 (3/4 in.)				015R1							
DN 25 (1 in.) / DN 20 (3/4 in.)				025E1							
DN 25 (1 in.) / DN 25 (1 in.)				025R0							
DN 25 (1 in.) / DN 40 (1-1/2 in.)				025R2							
DN 50 (2 in.) / DN 40 (1-1/2 in.)				050E1							
DN 50 (2 in.) / DN 50 (2 in.)				050R0							
DN 50 (2 in.) / DN 65 (2-1/2 in.)				050R1							
DN 80 (3 in.) / DN 65 (2-1/2 in.)				080E1							
DN 80 (3 in.) / DN 80 (3 in.)				080R0							
DN 80 (3 in.) / DN 100 (4 in.)				080R1							
DN 100 (4 in.) / DN 80 (3 in.)				100E1							
DN 100 (4 in.) / DN 100 (4 in.)				100R0							
DN 100 (4 in.) / DN 150 (6 in.)				100R2							
DN 150 (6 in.) / DN 100 (4 in.)				150E2							
DN 150 (6 in.) / DN 150 (6 in.)				150R0							
DN 150 (6 in.) / DN 200 (8 in.)				150R2							

CoriolisMaster FCB430, FCB450, FCH430, FCH450

Coriolis mass flowmeter

Main ordering information							
CoriolisMaster FCB430 Coriolis Mass Flowmeter	XX	XX	X	X	XX	XX	X
CoriolisMaster FCB450 Coriolis Mass Flowmeter	XX	XX	X	X	XX	XX	X
Process Connection Type							
Flanges DIN PN 16	D2				Continued see next page		
Flanges DIN PN 40	D4						
Flanges DIN PN 63	D5						
Flanges DIN PN 100	D6						
Flanges EN 1092-1 PN 40, NAMUR length (DN 15: 510 mm, DN 25: 600 mm, DN 50: 715 mm)	S5						
Flanges with groove PN40 EN1092-10-D	S6						
Flanges EN 1092-1 PN 16, NAMUR length (DN 15: 510 mm, DN 25: 600 mm, DN 50: 715 mm)	S7						
Flanges ANSI / ASME B16.5 Class 150	A1						
Flanges ANSI / ASME B16.5 Class 300	A3						
Flanges ANSI / ASME B16.5 Class 600	A6						
Flanges ANSI / ASME B16.5 Class 900 (p-t rating CI 600)	A7						
Flanges ANSI / ASME B16.5 Class 1500 (p-t rating CI 600)	A8						
Flanges JIS 10K	J1						
Sanitary Couplings SMS1145 for pipes acc. DIN11866 Series A	K1						
Tri-Clamp acc. DIN 32676	T1						
Tri-Clamp acc. BPE	T3						
Food industry fittings acc. DIN 11851	F1						
Female NPT thread	N5						
Female G thread	M5						
Others	Z9						
Material of Wetted Parts							
Stainless steel				A1			
Ni-Alloy				1)	C1		
Flow Calibration							
Flow forward +/- 0.40 % of flow rate, Gas 1 % of flow rate				2)	A		
Flow forward +/- 0.25 % of flow rate, Gas 1 % of flow rate				2)	B		
Flow forward +/- 0.2 % of flow rate, Gas 1 % of flow rate				2)	E		
Forward +/-0.15% of flow rate, Gas 0.5 % of flow rate				3)	C		
Forward +/-0.10% of flow rate, Gas 0.5 % of flow rate				3)	D		
Flow forward / reverse +/- 0.40 % of flow rate, Gas 1 % of flow rate				2)	J		
Flow forward / reverse +/- 0.25 % of flow rate, Gas 1 % of flow rate				2)	K		
Flow forward / reverse +/- 0.20 % of flow rate, Gas 1 % of flow rate				2)	N		
Flow forward / reverse +/- 0.15 % of flow rate, Gas 0.5 % of flow rate				3)	L		
Flow forward / reverse +/- 0.10 % of flow rate, Gas 0.5 % of flow rate				3)	M		
Others					Z		
Density Calibration							
Density 10 g/l				1)	1		
Density 2 g/l				3)	3		
Density 1 g/l				3)	4		
Others					9		

Main ordering information

CoriolisMaster FCB430 Coriolis Mass Flowmeter	XX	XX	X
CoriolisMaster FCB450 Coriolis Mass Flowmeter	XX	XX	X
Connection Design / Transmitter Housing Type / Transmitter Housing Material / Cable Glands			
Integral / Single-compartment / Aluminum / 3 x M20 x 1,5	S1		
Integral / Single-compartment / Aluminum / 3 x NPT 1/2 in.	S2		
Integral / Dual compartment / Aluminum / 3 x M20 x 1.5	D1		
Integral / Dual compartment / Aluminum / 3 x NPT 1/2 in.	D2		
Integral / Dual compartment / Aluminum / 3 x NPT 1/2 in. (Exd, XP)	D5		
Integral / Dual compartment / Aluminum / 3 x M20 x 1.5 (Exd, XP)	D6		
Remote / Not specified	Y0		
Others	Z9		
Outputs			
Current output 1 (active or passive), digital output 1 & 2 (passive), HART		G0	
Current output 1 (active or passive), digital output 1 & 2 (passive), 24 V DC transmitter loop power supply, HART		G1	
Current output 1 (active or passive), digital output 1 & 2 (passive), current output 2 (passive), HART		G2	
Current output 1 (active or passive), digital output 1 & 2 (passive), current output 2 (passive), current output 3 (passive), HART		G3	
Current output 1 (active or passive), digital output 1 & 2 (passive), current output 2 (passive), 24 V DC transmitter loop power supply, HART		G4	
Without		Y0	
Power Supply			
100 ... 230 V AC			A
11 ... 30 V DC			C
Without			Y

Additional ordering information

CoriolisMaster FCB430 Coriolis Mass Flowmeter	XX
CoriolisMaster FCB450 Coriolis Mass Flowmeter	XX
Certificates	
Test report 2.2 acc. EN 10204 confirmation of material	C1
Material monitoring with inspection certificate 3.1 acc. EN 10204	C2
Material monitoring with inspection certificate 3.2 acc. EN 10204	C3
Material monitoring NACE MR 01-75 with inspection certificate 3.1 acc. EN 10204	CN
Declaration of compliance with the order 2.1 acc. EN 10204	C4
Inspection certificate 3.1 acc. EN 10204 for visual, dimensional and functional test	C6
Inspection certificate 3.1 acc. EN 10204 for positive material identification PMI (confirmation only)	CA
Pressure test acc. AD2000	CB
Test package (pressure test, non-destructive test, welder & welding procedure certificate)	CT
Inspection certificate 3.1 acc. EN 10204 for NDE of welds	C8
Certificate of accuracy 2.1 acc. EN 10204	CM
Inspection certificate 3.1 acc. EN 10204 for positive material identification PMI (inclusive heat analysis)	CR
Others	CZ

CoriolisMaster FCB430, FCB450, FCH430, FCH450

Coriolis mass flowmeter

Additional ordering information								
CoriolisMaster FCB430 Coriolis Mass Flowmeter	XX	XXX	XXX	XX	XXX	XX	XX	XXX
CoriolisMaster FCB450 Coriolis Mass Flowmeter	XX	XXX	XXX	XX	XXX	XX	XX	XXX
Functional Safety								
SIL2 certificate	CS							
Additional Output 1								
1 x Digital input		DRN						
1 x Digital output		DRG						
1 x Analog output passive (4 ... 20 mA)		DRA						
24 V DC transmitter loop power supply		DRT						
Additional Output 2								
1 x Digital input			DSN					
1 x Digital output			DSG					
1 x Analog output passive (4 ... 20 mA)			DSA					
Integrated Digital Display (LCD)								
No Display, with Blind Cover					L0			
With capacitive sensorbuttons / Display (TTG) / Glass cover					L2			
Device Display Language								
German						BM1		
English						BM5		
French						BM4		
Spanish						BM3		
Italien						BM2		
Portuguese						BMA		
Chinese						BM6		
Documentation Language								
German							M1	
English							M5	
Language package Western Europe / Scandinavia (Languages: DA, ES, FR, IT, NL, PT, FI, SV)							MW	
Language package Eastern Europe (Languages: EL, CS, ET, LV, LT, HU, HR, PL, SK, SL, RO, BG)							ME	
Others							MZ	
Special Operation Mode								
Standard + DensiMass concentration measurement							3)	N6
Standard + Filling application							3)	N5
VeriMass - Meter verification								N7
Pressure Rating of Sensor Secondary Containment								
Maximum burst pressure 6 MPa / 60 bar / 870 psi inclusive tower length extension								PR5
Maximum burst pressure 10 MPa / 100 bar / 1450 psi inclusive tower length extension								PR6
Maximum burst pressure 15 MPa / 150 bar / 2175 psi inclusive tower length extension								PR7

Additional ordering information

CoriolisMaster FCB430 Coriolis Mass Flowmeter	XXX	XX	XXX	XXX
CoriolisMaster FCB450 Coriolis Mass Flowmeter	XXX	XX	XXX	XXX
Signal Cable Length				
Without signal cable	SC0			
5 m (approx. 15 ft)	SC1			
10 m (approx. 30 ft)	SC2			
20 m (approx. 66 ft)	SC4			
25 m (approx. 82 ft)	SC5			
30 m (approx. 98 ft)	SC6			
40 m (approx. 131 ft)	SC8			
50 m (approx. 164 ft)	SCA			
100 m (approx. 328 ft)	SCE			
150 m (approx. 492 ft)	SCG			
200 m (approx. 656 ft)	SCJ			
Others	SCZ			
Device Identification Plate				
Stainless steel plate with TAG no.			T1	
Others			TZ	
Ambient Temperature Range				
-40 ... 70 °C (-40 ... 158 °F)			TA9	
Extended Tower Length				
Tower length extension - meter insulation capability				TE1
Tower length extension - meter insulation capability with double sealing				TE2

- 1) If the sensor wetted parts are Ni-Alloy based, parts of the sensor housing are Ni-Alloy based too.
- 2) Only with CoriolisMaster FCB430
- 3) Only with CoriolisMaster FCB450

CoriolisMaster FCB430, FCB450, FCH430, FCH450

Coriolis mass flowmeter

Main ordering information CoriolisMaster FCH430, FCH450

Base model											
CoriolisMaster FCH430 Coriolis Mass Flowmeter	FCH430	XX	XX	XXXXX	XX	XX	X	X	XX	XX	X
CoriolisMaster FCH450 Coriolis Mass Flowmeter	FCH450	XX	XX	XXXXX	XX	XX	X	X	XX	XX	X
Explosion Protection Certification											
General Purpose		Y0									
ATEX / IECEx (Zone 2 / 22)		A2									
ATEX / IECEx (Zone 1 / 21)		A1									
cFMus version Class 1 Div. 2 (Zone 2 / 21)		F2									
cFMus version Class 1 Div. 1 (Zone 1 / 21)		F1									
Connection Design / Connection Box Material / Cable Glands											
Integral, defined by Transmitter housing		Y0									
Remote / Aluminium / 1 x M20 x 1.5		U1									
Remote / Aluminium / 1 x NPT 1/2 in.		U2									
Remote / Stainless Steel / 1 x M20 x 1.5		A1									
Remote / Stainless Steel / 1 x NPT 1/2 in.		A2									
Meter Size / Connection Size											
DN 25 (1 in.) / DN 20 (3/4 in.)						025E1					
DN 25 (1 in.) / DN 25 (1 in.)						025R0					
DN 25 (1 in.) / DN 40 (1-1/2 in.)						025R2					
DN 50 (2 in.) / DN 40 (1-1/2 in.)						050E1					
DN 50 (2 in.) / DN 50 (2 in.)						050R0					
DN 50 (2 in.) / DN 65 (2-1/2 in.)						050R1					
DN 80 (3 in.) / DN 65 (2-1/2 in.)						080E1					
DN 80 (3 in.) / DN 80 (3 in.)						080R0					
DN 80 (3 in.) / DN 100 (4 in.)						080R1					
Process Connection Type											
Tri-Clamp acc. DIN 32676							T1				
Tri-Clamp acc. BPE							T3				
Food industry fittings acc. DIN 11851							F1				
Others							Z9				

Continued see next page

Main ordering information

CoriolisMaster FCH430 Coriolis Mass Flowmeter	XX	X	X	XX	XX	X
CoriolisMaster FCH450 Coriolis Mass Flowmeter	XX	X	X	XX	XX	X

Material of Wetted Parts

Stainless steel polished 316L (1.4404 / 1.4435)	H2
---	----

Flow Calibration

Flow forward +/- 0.40 % of flow rate, Gas 1 % of flow rate	1)	A
Flow forward +/- 0.25 % of flow rate, Gas 1 % of flow rate	1)	B
Flow forward +/- 0.2 % of flow rate, Gas 1 % of flow rate	1)	E
Forward +/-0.15% of flow rate, Gas 0.5 % of flow rate	2)	C
Forward +/-0.10% of flow rate, Gas 0.5 % of flow rate	2)	D
Flow forward / reverse +/- 0.40 % of flow rate, Gas 1 % of flow rate	1)	J
Flow forward / reverse +/- 0.25 % of flow rate, Gas 1 % of flow rate	1)	K
Flow forward / reverse +/- 0.20 % of flow rate, Gas 1 % of flow rate	1)	N
Flow forward / reverse +/- 0.15 % of flow rate, Gas 0.5 % of flow rate	2)	L
Flow forward / reverse +/- 0.10 % of flow rate, Gas 0.5 % of flow rate	2)	M
Others		Z

Density Calibration

Density 10 g/l	1)	1
Density 2 g/l	2)	3
Density 1 g/l	2)	4
Others		9

Connection Design / Transmitter Housing Type / Transmitter Housing Material / Cable Glands

Integral / Single-compartment / Aluminum / 3 x M20 x 1,5	S1
Integral / Single-compartment / Aluminum / 3 x NPT 1/2 in.	S2
Integral / Dual compartment / Aluminium / 3 x M20 x 1.5	D1
Integral / Dual compartment / Aluminium / 3 x NPT 1/2 in.	D2
Integral / Dual compartment / Aluminium / 3 x NPT 1/2 in. (Exd, XP)	D5
Integral / Dual compartment / Aluminium / 3 x M20 x 1.5 (Exd, XP)	D6
Remote / Not specified	Y0
Others	Z9

Outputs

Current output 1 (active or passive), digital output 1 & 2 (passive), HART	G0
Current output 1 (active or passive), digital output 1 & 2 (passive), 24 V DC transmitter loop power supply, HART	G1
Current output 1 (active or passive), digital output 1 & 2 (passive), current output 2 (passive), HART	G2
Current output 1 (active or passive), digital output 1 & 2 (passive), current output 2 (passive), current output 3 (passive), HART	G3
Current output 1 (active or passive), digital output 1 & 2 (passive), current output 2 (passive), 24 V DC transmitter loop power supply, HART	G4
Without	Y0

Power Supply

100 ... 230 V AC	A
11 ... 30 V DC	C
Without	Y

CoriolisMaster FCB430, FCB450, FCH430, FCH450

Coriolis mass flowmeter

Additional ordering information

CoriolisMaster FCH430 Coriolis Mass Flowmeter	XX	XX	XXX	XXX	XX	XX
CoriolisMaster FCH450 Coriolis Mass Flowmeter	XX	XX	XXX	XXX	XX	XX
Certificates						
Test report 2.2 acc. EN 10204	C1					
Material monitoring with inspection certificate 3.1 acc. EN 10204	C2					
Material monitoring NACE MR 01-75 with inspection certificate 3.1 acc. EN 10204	CN					
Declaration of compliance with the order 2.1 acc. EN 10204	C4					
Inspection certificate 3.1 acc. EN 10204 for visual, dimensional and functional test	C6					
Inspection certificate 3.1 acc. EN 10204 for positive material identification PMI (confirmation only)	CA					
Pressure test acc. AD2000	CB					
Test package (pressure test, non-destructive test, welder & welding procedure certificate)	CT					
Certificate of compliance for calibration 2.1 acc. EN 10204	CM					
Inspection certificate 3.1 acc. EN 10204 for positive material identification PMI (inclusive heat analysis)	CR					
Others	CZ					
Functional Safety						
SIL2 certificate			CS			
Additional Output 1						
1 x Digital input				DRN		
1 x Digital output				DRG		
1 x Analog output passive (4 ... 20 mA)				DRA		
24 V DC transmitter loop power supply				DRT		
Additional Output 2						
1 x Digital input					DSN	
1 x Digital output					DSG	
1 x Analog output passive (4 ... 20 mA)					DSA	
Integrated Digital Display (LCD)						
No Display, with Blind Cover						L0
With capacitive sensorbuttons / Display (TTG) / Glass cover						L2
Device Display Language						
German						BM1
English						BM5
French						BM4
Spanish						BM3
Italian						BM2
Portuguese						BMA
Chinese						BM6

Additional ordering information

CoriolisMaster FCH430 Coriolis Mass Flowmeter	XX	XX	XXX	XX	XXX	XXX
CoriolisMaster FCH450 Coriolis Mass Flowmeter	XX	XX	XXX	XX	XXX	XXX
Documentation Language						
German	M1					
English	M5					
Language package Western Europe / Scandinavia (Languages: DA, ES, FR, IT, NL, PT, FI, SV)	MW					
Language package Eastern Europe (Languages: EL, CS, ET, LV, LT, HU, HR, PL, SK, SL, RO, BG)	ME					
Others	MZ					
Special Operation Mode						
Standard + Filling application	2)	N5				
Standard + DensiMass concentration measurement	2)	N6				
VeriMass - Meter verification		N7				
Signal Cable Length						
Without signal cable					SC0	
5 m (ca. 15 ft)					SC1	
10 m (ca. 30 ft)					SC2	
20 m (ca. 66 ft)					SC4	
25 m (ca. 82 ft)					SC5	
30 m (ca. 98 ft)					SC6	
40 m (ca. 131 ft)					SC8	
50 m (ca. 164 ft)					SCA	
100 m (ca. 328 ft)					SCE	
150 m (ca. 492 ft)					SCG	
200 m (ca. 656 ft)					SCJ	
Others					SCZ	
Device Identification Plate						
Stainless steel plate with TAG no.						T1
Others						TZ
Ambient Temperature Range						
-40 ... 70 °C (-40 ... 158 °F)						TA9
Extended Tower Length						
Tower length extension - meter insulation capability						TE1
Tower length extension - meter insulation capability with double sealing						TE2

1) Only with CoriolisMaster FCH430

2) Only with CoriolisMaster FCH450

CoriolisMaster FCB430, FCB450, FCH430, FCH450

Coriolis mass flowmeter

Transmitter

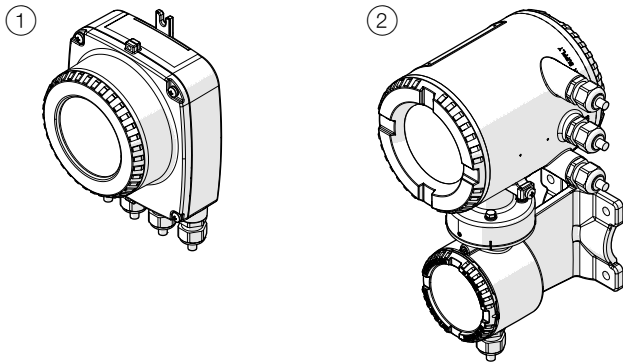

G11559-01

Fig. 29: Transmitter FCT4xx in field mount housing (remote mount design)

① Single-compartment housing ② Dual-compartment housing

Features

- 4 ... 20 mA current / HART 7.1 output.
- Current output in the event of an alarm can be configured to 21 ... 23 mA (NAMUR NE43).
- Measuring range: Can be configured between 0.1 ... 1 x Q_{maxDN} .
- Programmable digital output. Can be configured as a frequency, pulse or binary output.
- Two slots for optional plug-in cards for retrofitting additional current / digital outputs or a digital input.
- Parameterization by means of HART communication.
- Response time ≥ 1 s, 0 ... 99 % as step function (corresponds to 5 τ)
- Damping: 0.2 ... 100 s configurable (1 τ).
- Low flow cut-off: 0 ... 5 % for current and pulse output.
- Measuring medium parameters can be changed at any time (pressure and temperature influence, density, units, etc.).
- Simulation of current and binary output (manual process execution).

LCD indicator (option)

- Indicator for all measured values of CoriolisMaster (e.g. mass flow, volume flow rate, density, temperature and many others).
- Application-specific visualizations which the user can select. Four operator pages can be configured to display multiple values in parallel.
- Plain text fault diagnostics
- Menu-guided parameterization with four buttons.
- "Easy Set-up" function for fast commissioning.
- Operation through the front glass via capacitive buttons.

Optional plug-in cards

The transmitter has two slots (OC1, OC2) in which plug-in cards can be inserted to provide additional inputs and outputs.

The slots are located on the transmitter motherboard and can be accessed after removing the front housing cover.

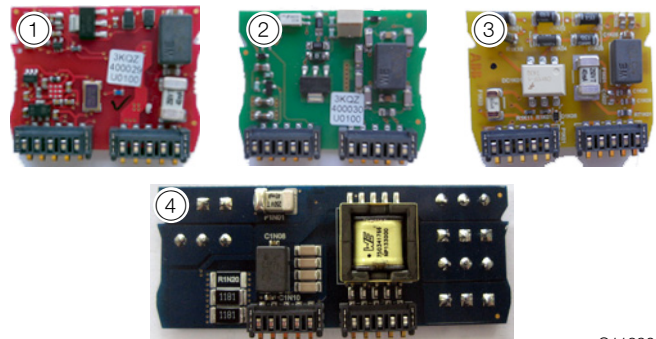

G11896

Fig. 30: Plug-in cards

Plug-in card	Number ¹⁾
① Passive current output, 4 ... 20 mA (red) Order no. 3KQZ400029U0100	2
② Passive digital output (green) Order no. 3KQZ400030U0100	1
③ Passive digital input (yellow) 3KQZ400032U0100	1
④ 24 V DC power supply (blue) 3KQZ400031U0100	1

1) The "Number" column indicates the maximum number of plug-in cards of the same type that can be used.

NOTICE

For an overview of possible plug-in card combinations, please refer to chapter "Possible plug-in card combinations" on page 63.

IP rating

In accordance with EN60529: IP 65 / IP 67, NEMA 4X

Vibration

In accordance with EN 60068-2

- In the 10 ... 58 Hz range, max. deflection 0.15 mm (0.006 inch)¹⁾
- In the range of 58...150 Hz, max. acceleration 2 g¹⁾

1) Peak load

Approved relative humidity

In accordance with EN 60068-2-30

Temperature Data

	Standard	Optional
Ambient temperature	-20 ... 70 °C (-4 ... 158 °F)	-40 ... 70 °C (-40 ... 158 °F)
Storage temperature	-40 ... 70 °C (-40 ... 158 °F)	—

NOTICE

When operating below -20 °C (-4 °F), the LCD display can no longer be read and the electronics should be operated with as few vibrations as possible. Full functionality is assured at temperatures above -20 °C (-4 °F).

Housing design

Integral mount design

Housing	Cast aluminum, painted
Paint	≥ 80 µm thick, RAL 9002 (gray white)
Cable gland	Polyamide Stainless steel ¹⁾

Remote mount design

Housing	Cast aluminum, painted
Paint	≥ 80 µm thick, mid-section RAL 7012 (basalt gray), front cover / rear cover RAL 9002 (gray white)
Cable gland	Polyamide M20 x 1.5 or 1/2" NPT Stainless steel ¹⁾ M20 x 1.5 or 1/2" NPT
Weight	4.5 kg (9.92 lb)

1) On explosion-proof design for ambient temperature of -40 °C (-40 °F)

Signal cables

Cable specification

Impedance	100 ... 200 Ω
Withstand voltage	120 V
Outer diameter	6 ... 12 mm (0.24 ... 0.47 inch)
Cable design	Two wire pairs as a star-quad cable
Conductor cross-section	Length-dependent
Shielding	Copper braid with approximately 85 % coverage
Temperature range	Depends on application, when using the device in potentially explosive atmospheres, observe chapter "Temperature resistance for the connecting cable" on page 71.

Maximum signal cable length

0.25 mm ² (AWG 24)	50 m (164 ft)
0.34 mm ² (AWG 22)	100 m (328 ft)
0.5 mm ² (AWG 20)	150 m (492 ft)
0.75 mm ² (AWG 19)	200 m (656 ft)

Recommended cables

It is recommended to use an ABB signal cable with the order number 3KQZ407123U0100 for standard applications. The ABB connection cable fulfills all above specifications and is suitable up to $T_{amb.} = 80\text{ °C}$ (176 °F) without limitations.

For marine applications, an appropriate certified signal cable must be used. ABB recommends the cable HELKAMA RFE-FRHF 2x2x0,75 QUAD 250V (HELKAMA order number 20522).

CoriolisMaster FCB430, FCB450, FCH430, FCH450 Coriolis mass flowmeter

Electrical connections

Electrical connection (HART protocol)

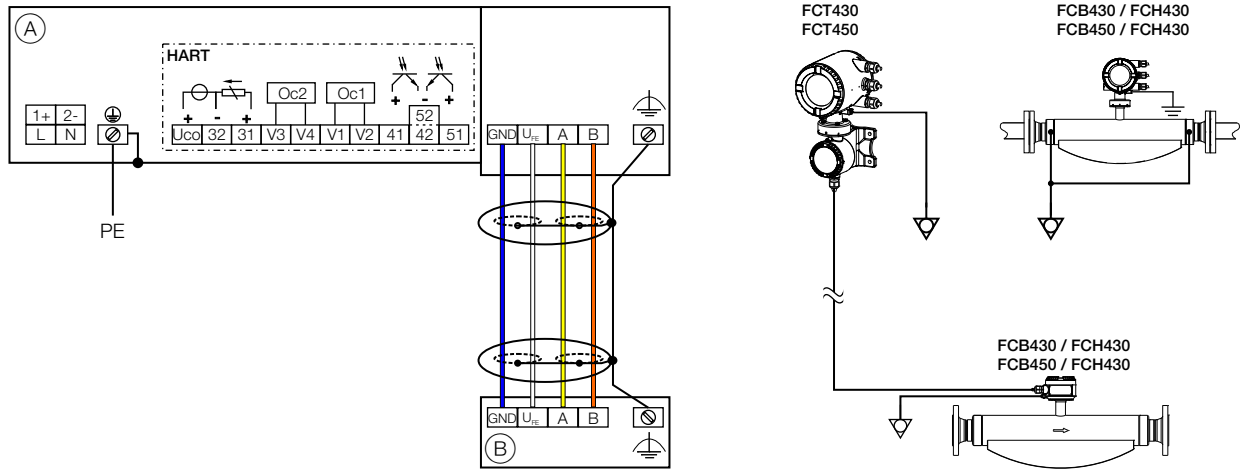

Fig. 31: (A) Transmitter (B) Sensor

Connections for the power supply

AC power supply	
Terminal	Function / comments
L	Phase
N	Neutral conductor
PE / ⊕	Protective earth (PE)
⚡	Potential equalization terminal

DC voltage supply	
Terminal	Function / comments
1+	+
2-	-
PE / ⊕	Protective earth (PE)
⚡	Potential equalization terminal

Connections for inputs and outputs

Terminal	Function / comments
Ucc / 31	Active 4 ... 20 mA current output / HART
31 / 32	Passive 4 ... 20 mA current output / HART
41 / 42	Passive digital output DO1 The output can be configured as a pulse output, frequency output or switch output on site.
51 / 52	Passive digital output DO2 The output can be configured as a pulse output, frequency output or switch output on site.
V1 / V2	Plug-in card, slot Oc1
V3 / V4	Plug-in card, slot Oc2 For details, see chapter "Optional plug-in cards" on page 54.

Connecting the signal cable

Only for remote mount design.

The sensor housing and transmitter housing must be connected to potential equalization.

Terminal	Function / comments
U _{FE}	Sensor power supply
GND	Ground
A	Data line
B	Data line
⚡	Functional earth / Shielding

Electrical data for inputs and outputs

NOTICE

When using the device in potentially explosive atmospheres, note the additional connection data in chapter "Use in potentially explosive atmospheres" on page 66!

Power supply L / N, 1+ / 2-

AC power supply	
Terminals	L / N
Operating voltage	100 ... 240 V AC, 50 / 60 Hz
Power consumption	< 20 VA

DC voltage supply	
Terminals	1+ / 2-
Operating voltage	11 ... 30 V DC
Power consumption	20 W

Current output 31 / Uco, 31 / 32 (basic device)

Can be configured for outputting mass flow, volume flow, density and temperature via on-site software.

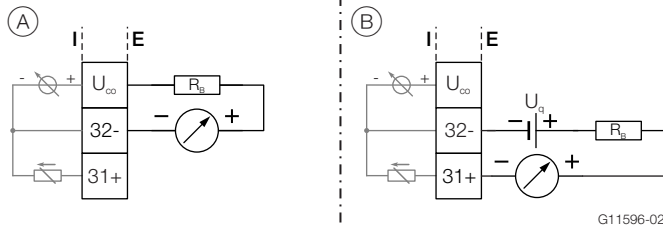
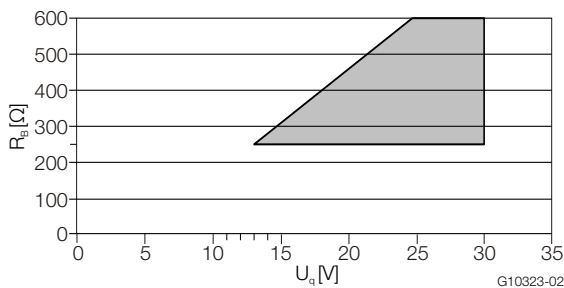

Fig. 32: (I = internal, E = external, R_B = load)

(A) Active current output 31 / Uco (B) Passive current output 31 / 32



Permissible source voltage U_q for passive outputs in relation to load resistance where $I_{max} = 22$ mA. ■■■ = Permissible range

Fig. 33: Source voltage for passive outputs

Current output	Active	Passive
Terminals	Uco / 31	31 / 32
Output signal	4 ... 20 mA or 4 ... 12 ... 20 mA, switchable	4 ... 20 mA
Load R_B	$250 \Omega \leq R_B \leq 300 \Omega$	$250 \Omega \leq R_B \leq 600 \Omega$
Source voltage U_q ¹⁾	—	$13 \text{ V} \leq U_q \leq 30 \text{ V}$
Measuring error	< 0.1 % of measured value	

1) The source voltage U_q depends on the load R_B and must be within the permissible range.

HART communication

In conjunction with the DTM (Device Type Manager) available to the device, communication (configuration, parameterization) can occur with the corresponding framework applications in accordance with FDT 0.98 or 1.2 (DSV401 R2).

Other tool/system integrations (e.g., Emerson AMS/Siemens PCS7) are available on request.

The necessary DTMs and other files can be downloaded from www.abb.com/flow.

HART output

Terminals	Active: Uco / 31 Passive: 31 / 32
Protocol	HART 7.1
Transmission	FSK modulation on current output 4 ... 20 mA in accordance with Bell 202 standard
Baud rate	1200 baud
Signal amplitude	Maximum 1.2 mAss

CoriolisMaster FCB430, FCB450, FCH430, FCH450

Coriolis mass flowmeter

Digital output 41 / 42, 51 / 52 (basic device)

Can be configured as pulse, frequency or binary output via on-site software.

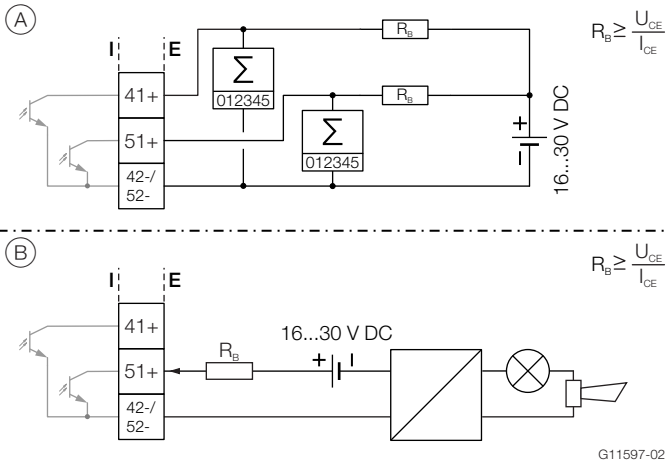

Fig. 34: (I = internal, E = external, R_B = load)

- Ⓐ Passive digital output 41 / 42, 51 / 52 as pulse or frequency output
- Ⓑ Passive digital output 51 / 52 as binary output

Pulse / frequency output (passive)	
Terminals	41 / 42, 51 / 52
Output "closed"	$0 \text{ V} \leq U_{CE\text{L}} \leq 3 \text{ V}$ For $f < 2.5 \text{ kHz}$: $2 \text{ mA} < I_{CE\text{L}} < 30 \text{ mA}$ For $f > 2.5 \text{ kHz}$: $10 \text{ mA} < I_{CE\text{L}} < 30 \text{ mA}$
Output "open"	$16 \text{ V} \leq U_{CE\text{H}} \leq 30 \text{ V DC}$ $0 \text{ mA} \leq I_{CE\text{H}} \leq 0.2 \text{ mA}$
fmax	10.5 kHz
Pulse width	0.1 ... 2000 ms

Binary output (passive)	
Terminals	41 / 42, 51 / 52
Output "closed"	$0 \text{ V} \leq U_{CE\text{L}} \leq 3 \text{ V}$ $2 \text{ mA} \leq I_{CE\text{L}} \leq 30 \text{ mA}$
Output "open"	$16 \text{ V} \leq U_{CE\text{H}} \leq 3 \text{ V DC}$ $0 \text{ mA} \leq I_{CE\text{H}} \leq 0.2 \text{ mA}$
Switching function	Can be configured using software. See chapter Parameter descriptions in the operating instruction.

NOTICE

- Terminals 42 / 52 have the same potential. Digital outputs DO 41 / 42 and DO 51 / 52 are not electrically isolated from each other. If an additional electrically isolated digital output is required, a corresponding plug-in card must be used.
- If you are using a mechanical counter, we recommend setting a pulse width of $\geq 30 \text{ ms}$ and a maximum frequency of $f_{\text{max}} \leq 3 \text{ kHz}$.

Current output V1 / V2, V3 / V4 (plug-in card)

Up to two additional current outputs can be implemented via the "Passive current output (red)" plug-in card.

Can be configured for outputting mass flow, volume flow, density and temperature via on-site software.

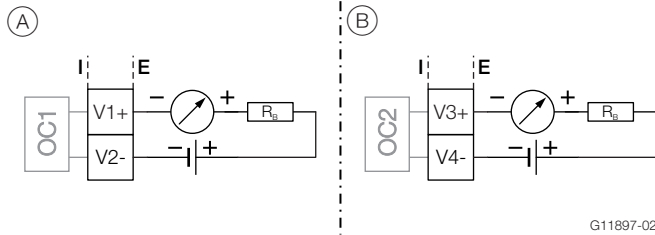
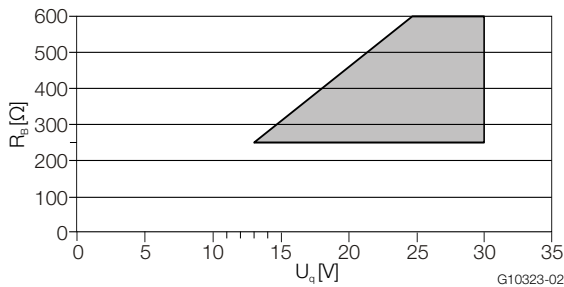

Fig. 35: (I = internal, E = external, R_B = load)

(A) Passive current output V1 / V2 (B) Passive current output V3 / V4

The plug-in card can be used in slot OC1 or in OC2.



Permissible source voltage U_q for passive outputs in relation to load resistance where $I_{max} = 22$ mA. ■■■ = Permissible range

Fig. 36: Source voltage for passive outputs

Passive current output

Terminals	V1 / V2, V3 / V4
Output signal	4 ... 20 mA
Load R_B	$250 \Omega \leq R_B \leq 600 \Omega$
Source voltage	$13 \text{ V} \leq U_q \leq 30 \text{ V}$
Measuring error	< 0.1 % of measured value

1) The source voltage U_q depends on the load R_B and must be within the permissible range.

Digital output V1 / V2, V3 / V4 (plug-in card)

An additional binary output can be implemented via the "Passive digital output (green)" plug-in card.

Can be configured as an output for flow direction signaling, alarm output etc. via on-site software.

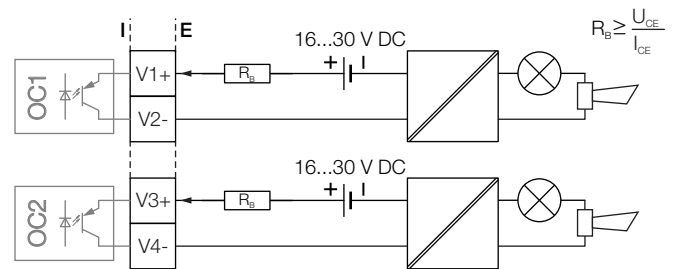

Fig. 37: Plug-in card as binary output (I = internal, E = external, R_B = load)

The plug-in card can be used in slot OC1 or in OC2.

Binary output (passive)

Terminals	V1 / V2, V3 / V4
Output "closed"	$0 \text{ V} \leq U_{CEL} \leq 3 \text{ V}$ $2 \text{ mA} < I_{CEL} < 30 \text{ mA}$
Output "open"	$16 \text{ V} \leq U_{CEH} \leq 30 \text{ V DC}$ $0 \text{ mA} \leq I_{CEH} \leq 0.2 \text{ mA}$
Switching function	Can be configured using software. See chapter Parameter descriptions in the operating instruction.

CoriolisMaster FCB430, FCB450, FCH430, FCH450

Coriolis mass flowmeter

Digital input V1 / V2, V3 / V4 (plug-in card)

A digital input can be implemented via the "Passive digital input (yellow)" plug-in card.

Can be configured as an input for external counter reset, external output deactivation etc. via on-site software.

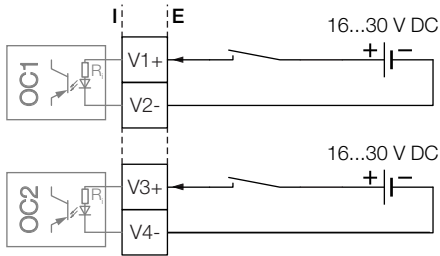

G11598-01

Fig. 38: Plug-in card as digital input (I = internal, E = external)

The plug-in card can be used in slot OC1 **or** in OC2.

Digital input

Terminals	V1 / V2, V3 / V4
Function	Can be configured using software. See chapter Parameter descriptions in the operating instruction.
Input "On"	$16 \text{ V} \leq U_{\text{KL}} \leq 30 \text{ V}$
Input "Off"	$0 \text{ V} \leq U_{\text{KL}} \leq 3 \text{ V}$
Internal resistance	$R_{\text{i}} = 6.5 \text{ k}\Omega$

24 V DC power supply (plug-in card)

The power supply plug-in card allows a passive output on the transmitter to be used as an active output. See chapter "Connection examples" on page 61.

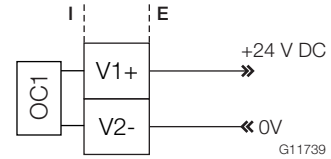

Fig. 39: (I = Internal, E = External)

The plug-in card can only be used in slot OC1.

24 V DC power supply

Terminals	V1 / V2
Function	For active connection of passive outputs
Output voltage	24 V DC at 0 mA, 17 V DC at 25 mA
Load rating I_{max}	25 mA, permanently short circuit-proof

NOTICE

When using the device in potentially explosive atmospheres, the power supply plug-in card must only be used to power one passive output. It must not be connected to multiple passive outputs!

Connection examples

Input and output functions are configured via the device software in accordance with the desired application. See chapter Parameter descriptions in the operating instruction.

Active digital output 41 / 42, 51 / 52, V3 / V4

When the "24 V DC power supply (blue)" plug-in card is used, the digital outputs on the basic device and on the plug-in cards can also be wired as active digital outputs.

i NOTICE

Each "power supply (blue)" plug-in card must only power one output.

It must not be connected to two outputs (e.g. digital output 41 / 42 and 51 / 52)!

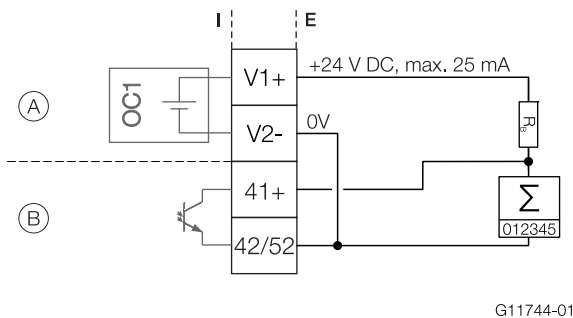

G11744-01

Fig. 40: Active digital output 41 / 42 (example)

- (A) Plug-in card "Power supply (blue)" in slot 1
- (B) Digital output, digital output 41 / 42

The connection example shows usage for digital output 41 / 42; the same applies to usage for digital output 51 / 52.

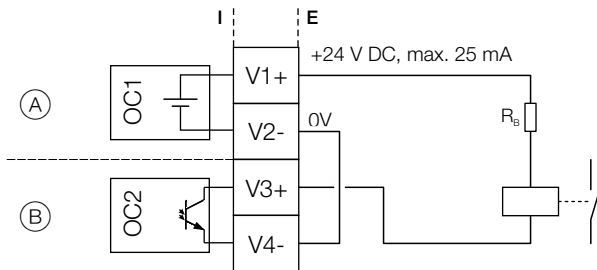

G11913

Fig. 41: Active digital output V3 / V4 (example)

- (A) Plug-in card "Power supply (blue)" in slot 1
- (B) Plug-in card "Digital output (green)" in slot 2

Active current output V3 / V4

When the "24 V DC power supply (blue)" plug-in card is used, the current output on the plug-in card can also be wired as the active current output.

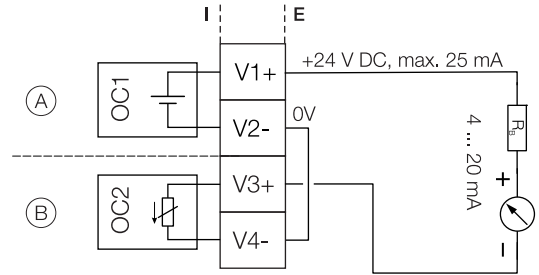

G11742-01

Fig. 42: Active current output V3 / V4 (example)

- (A) Plug-in card "Power supply (blue)" in slot 1
- (B) Plug-in card "Passive current output (red)" in slot 2

Active digital input V3 / V4

When the "24 V DC power supply (blue)" plug-in card is used, the digital input on the plug-in card can also be wired as the active digital input.

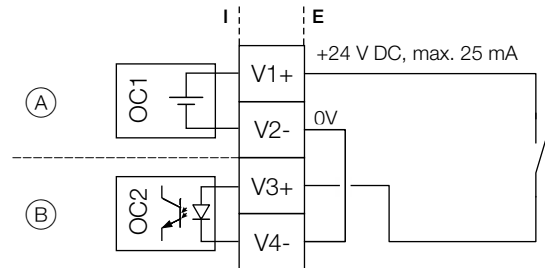

G11914

Fig. 43: Active digital input V3 / V4 (example)

- (A) Plug-in card "Power supply (blue)" in slot 1
- (B) Plug-in card "Passive digital input (yellow)" in slot 2

CoriolisMaster FCB430, FCB450, FCH430, FCH450

Coriolis mass flowmeter

Dimensions

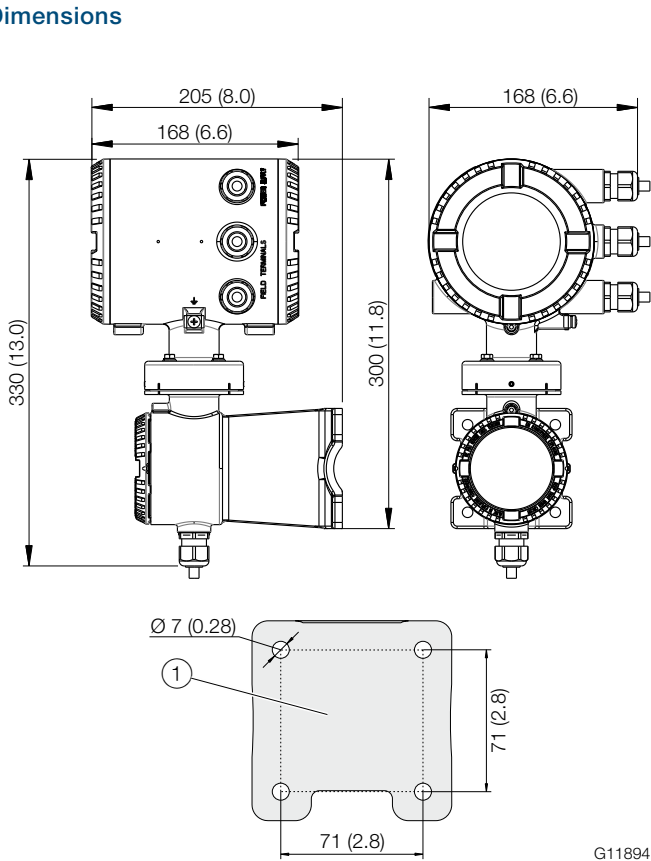

G11894

Fig. 44: Mounting dimensions of double-compartment housing

① Hole pattern for mounting holes

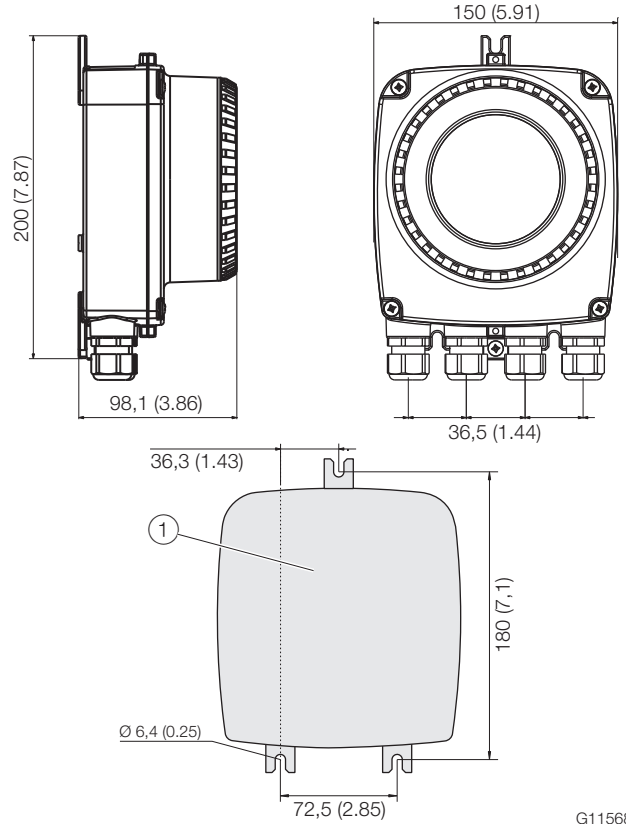

G11568

Fig. 45: Mounting dimensions single-compartment housing

① Hole pattern for mounting holes

Ordering information

Possible plug-in card combinations

The following table provides an overview of the possible combinations of plug-in card combinations that can be selected when ordering the device.

Main ordering information (outputs)	Additional ordering information		Slot OC1 Terminals V1 / V2	Slot OC2 Terminals V3 / V4
	Additional output 1	Additional output 2		
G0	—	—	—	—
G1	—	—	24 V DC power supply (blue)	—
G2	—	—	—	Passive current output (red)
G3	—	—	Passive current output, 4 ... 20 mA (red)	Passive current output, 4 ... 20 mA (red)
G4	—	—	24 V DC power supply (blue)	Passive current output (red)
G0	DRT	—	24 V DC power supply (blue)	—
G0	DRT	DSN	24 V DC power supply (blue)	Passive digital input (yellow)
G0	DRT	DSG	24 V DC power supply (blue)	Passive digital output (green)
G0	DRT	DSA	24 V DC power supply (blue)	Passive current output, 4 ... 20 mA (red)
G0	DRN	—	Passive digital input (yellow)	—
G0	DRN	DSG	Passive digital input (yellow)	Passive digital output (green)
G0	DRN	DSA	Passive digital input (yellow)	Passive current output, 4 ... 20 mA (red)
G0	DRG	DSN	Passive digital output (green)	Passive digital input (yellow)
G0	DRG	DSA	Passive digital output (green)	Passive current output, 4 ... 20 mA (red)
G0	DRA	DSA	Passive current output, 4 ... 20 mA (red)	Passive current output, 4 ... 20 mA (red)
G0	DRA	DSG	Passive current output, 4 ... 20 mA (red)	Passive digital output (green)
G0	DRA	DSN	Passive current output, 4 ... 20 mA (red)	Passive digital input (yellow)

CoriolisMaster FCB430, FCB450, FCH430, FCH450

Coriolis mass flowmeter

Main ordering information CoriolisMaster FCT430, FCT450 Coriolis Mass Flowmeter Transmitter

Base model					
CoriolisMaster FCT430 Coriolis Mass Flowmeter Transmitter	FCT430	XX	XX	XX	X
CoriolisMaster FCT450 Coriolis Mass Flowmeter Transmitter	FCT450	XX	XX	XX	X
Explosion Protection Certification					
General Purpose		Y0			
ATEX / IECEx (Zone 2 / 22)		A2			
ATEX / IECEx (Zone 1 / 21)		A1			
cFMus version Class 1 Div. 2 (Zone 2 / 21)		F2			
cFMus version Class 1 Div. 1 (Zone 1 / 21)		F1			
Connection Design / Transmitter Housing Type / Transmitter Housing Material / Cable Glands					
Remote / Single-compartment / Aluminum / 4 x M20 x 1.5				W1	
Remote / Single-compartment / Aluminum / 4 x NPT 1/2 in.				W2	
Remote / Dual compartment, wall mounted / Aluminum / 4 x M20 x 1.5				R1	
Remote / Dual compartment, wall mounted / Aluminum / 4 x NPT 1/2 in.				R2	
Remote / Dual compartment, wall mounted / Aluminum / 4 x M20 x 1.5 (Exd, XP)				R5	
Remote / Dual compartment, wall mounted / Aluminum / 4 x NPT 1/2 in. (Exd, XP)				R6	
Others				Z9	
Outputs					
Current output 1 (active or passive), digital output 1 & 2 (passive), HART				G0	
Current output 1 (active or passive), digital output 1 & 2 (passive), 24 V DC transmitter loop power supply, HART				G1	
Current output 1 (active or passive), digital output 1 & 2 (passive), current output 2 (passive), HART				G2	
Current output 1 (active or passive), digital output 1 & 2 (passive), current output 2 (passive), current output 3 (passive), HART				G3	
Current output 1 (active or passive), digital output 1 & 2 (passive), current output 2 (passive), 24 V DC transmitter loop power supply, HART				G4	
Others				Z9	
Power Supply					
100 ... 230 V AC					A
11 ... 30 V DC					C

Additional ordering information

Additional ordering information

CoriolisMaster FCT430 Coriolis Mass Flowmeter Transmitter	XX	XX	XXX	XXX	XX	XXX	XX	XX
CoriolisMaster FCT450 Coriolis Mass Flowmeter Transmitter	XX	XX	XXX	XXX	XX	XXX	XX	XX
Mounting Bracket Shape / Material								
For 2 in. pipe mounting / Carbon steel	B1							
Certificates								
Declaration of compliance with the order 2.1 acc. EN 10204	C4							
Inspection certificate 3.1 acc. EN 10204 for visual, dimensional and functional test	C6							
Additional Output 1								
1 x Digital input	DRN							
1 x Digital output	DRG							
1 x Analog output passive (4 ... 20 mA)	DRA							
24 V DC transmitter loop power supply	DRT							
Additional Output 2								
1 x Digital input	DSN							
1 x Digital output	DSG							
1 x Analog output passive (4 ... 20 mA)	DSA							
Integrated Digital Display (LCD)								
No Display, with Blind Cover	L0							
With capacitive sensorbuttons / Display (TTG) / Glass cover	L2							
Device Display Language								
German	BM1							
English	BM5							
French	BM4							
Spanish	BM3							
Italien	BM2							
Portuguese	BMA							
Chinese	BM6							
Documentation Language								
German	M1							
English	M5							
Language package Western Europe / Scandinavia (Languages: DA, ES, FR, IT, NL, PT, FI, SV)	MW							
Language package Eastern Europe (Languages: EL, CS, ET, LV, LT, HU, HR, PL, SK, SL, RO, BG)	ME							
Others	MZ							
Device Identification Plate								
Stainless steel plate with TAG no.	T1							

CoriolisMaster FCB430, FCB450, FCH430, FCH450

Coriolis mass flowmeter





Use in potentially explosive atmospheres

NOTICE

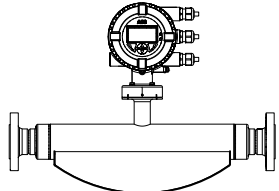
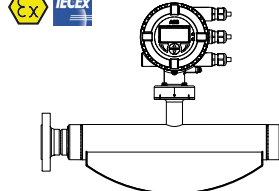
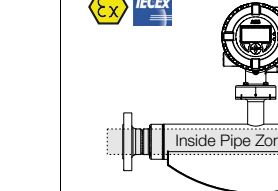
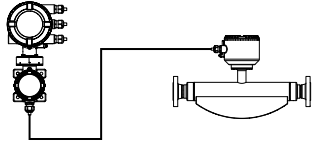
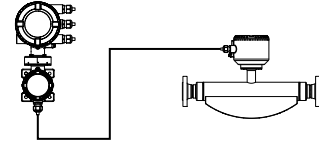
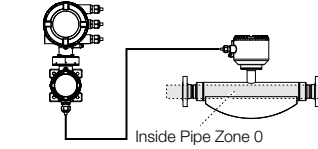

Further information on the approval of devices for use in potentially explosive atmospheres can be found in the type examination certificates or the relevant certificates at www.abb.com/flow.

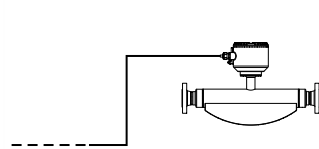
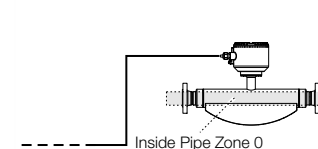
Device overview

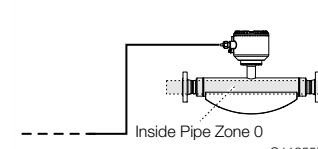
ATEX / IECEx

	Standard / No explosion protection		Zone 2, 21, 22		Zone 1, 21 (Zone 0)	
Model number	FCx4xx Y0		FCx4xx A2		FCx4xx A1	
Integral mount design – Standard – Zone 2, 21, 22 – Zone 1, 21 – Zone 0						
Model number	FCT4xx Y0	FCx4xx Y0	FCT4xx A2	FCx4xx A2	FCT4xx A1	FCx4xx A1
Remote mount design Transmitter and flowmeter sensor – Standard – Zone 2, 21, 22 – Zone 1, 21 – Zone 0						
Model number	FCT4xx Y0		FCT4xx A2		FCx4xx A1	
Remote mount design Transmitter – Standard – Zone 2, 21, 22 Sensor – Zone 1, 21 – Zone 0						
Model number	–		FCT4xx A2		FCx4xx A1	
Remote mount design Transmitter – Zone 2, 21, 22 Sensor – Zone 1, 21	–					

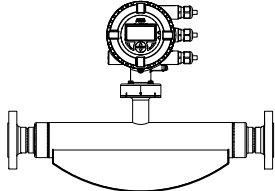
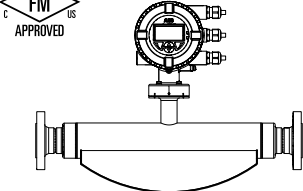
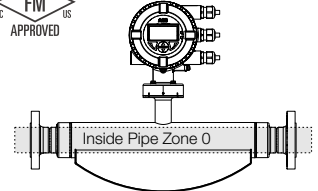
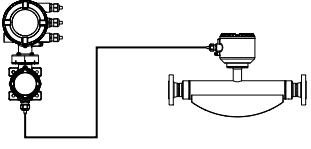
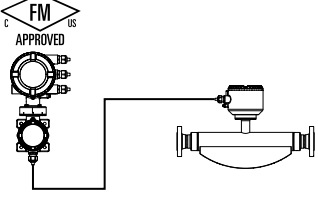
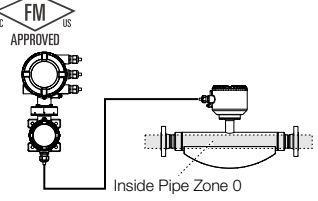
cFMus

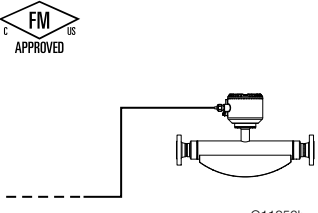
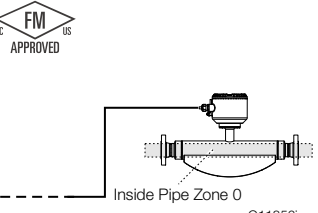
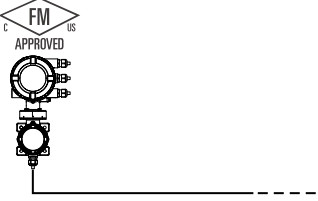
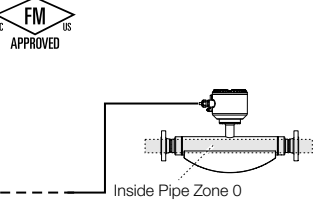
	Standard / No explosion protection		Class I, Div. 2 / Zone 2		Class I, Div. 1 / Zone 1 (Zone 0)	
Model number	FCx4xx Y0		FCx4xx F2		FCx4xx F1	
Integral mount design — Standard — Div. 2 / Zone 2 — Div. 1 / Zone 1 (Zone 0)	 <p>G11856a</p>		 <p>G11856b</p>		 <p>G11856c</p>	
Model number	FCT4xx Y0	FCx4xx Y0	FCT4xx F2	FCx4xx F2	FCT4xx F1	FCx4xx F1
Remote mount design Transmitter and flowmeter sensor — Div. 2 / Zone 2 — Div. 1 / Zone 1 (Zone 0)	 <p>G11855d</p>		 <p>G11856e</p>		 <p>G11856f</p>	
Model number	FCT4xx Y0		FCT4xx F2		FCx4xx F1	
Remote mount design Transmitter — Standard Sensor — Div. 2 / Zone 2 — Div. 1 / Zone 1 (Zone 0)	 <p>G11855g</p>		 <p>G11856h</p>		 <p>G11856i</p>	
Model number	—		FCT4xx F2		FCx4xx F1	
Remote mount design Transmitter — Div. 2 / Zone 2 Sensor — Div. 1 / Zone 1 (Zone 0)	—		 <p>G11856j</p>		 <p>G11856i</p>	

CoriolisMaster FCB430, FCB450, FCH430, FCH450

Coriolis mass flowmeter

Ex-marking

Description of model numbers

Each device design has a specific model number. The parts of the model number relating to explosion protection are listed in the following table. The complete key to model numbers and the choices are described in chapter "Ordering information" on page 45 (flowmeter sensor) and "Ordering information" on page 63 (remote transmitter).

Basic model	Fca4c	XX	XX	f	g	h	i	j	XX	l	m
Explosion protection											
Design / terminal box material / cable glands											
Nominal diameter / nominal connection diameter											
Process connection											
Material for wetted parts											
Flow rate calibration											
Density calibration											
Design / transmitter housing / transmitter housing material / cable gland											
Outputs											
Power supply											

ATEX / IECEx

Model number and brief description in Zone 2, 21

FCa4c – A2Y0fghijD

Integral mount design with dual-compartment housing

FCa4c – A2efghijY

Sensor in remote mount design with dual-compartment housing

FCT4c – A2R

Transmitter in remote mount design with dual-compartment housing

Ex-marking

II 3 G Ex nA IIC T6...T1 Gc

II 2 D Ex tb IIIC T80°C Db

Certificate

– ATEX: FM15ATEX0014X, FM15ATEX0016X

– IECEx: IECEx FME 15.0005X

Model number, brief description and marking in Zone 1, 21

FCa4c – A1Y0fghijDx (x = 1 ... 4)

Integral mount design with dual-compartment housing

II 1/2 (1) G Ex d e ia mb [ia Ga] IIC T6...T1 Gb

II 2 (1) D Ex ia tb [ia Da] IIIC T80°C Db

FCa4c – A1Y0fghijDx (x = 5 ... 8)

Integral mount design with dual-compartment housing (flameproof enclosure "Ex d")

II 1/2 (1) G Ex d ia mb [ia Ga] IIB+H2 T6...T1 Gb

II 2 (1) D Ex ia tb [ia Da] IIIC T80°C Db

FCa4c – A1efghijY

Sensor in remote mount design with dual-compartment housing

II 1/2 G Ex e ia mb IIB+H2 T6...T1 Ga/Gb

II 2 D Ex ia tb IIIC T80°C Db

FCT4c – A1R (x = 1 ... 4)

Transmitter in remote mount design with dual-compartment housing

II 2 (1) G Ex d e ia mb [ia Ga] IIC T6...T1 Gb

II 2 (1) D Ex ia mb tb [ia Da] IIIC T80°C Db

FCT4c – A1R (x = 5 ... 8)

Transmitter in remote mount design with dual-compartment housing (flameproof enclosure "Ex d")

II 2 (1) G Ex d ia mb [ia Ga] IIB+H2 T6...T1 Gb

II 2 (1) D Ex ia tb [ia Da] IIIC T80°C Db

Certificate

– ATEX: FM15ATEX0015X

– IECEx: IECEx FME 15.0005X

NOTICE

- Depending on the design, a specific marking in accordance with ATEX or IECEx applies.
- ABB reserves the right to modify the Ex-marking. Refer to the name plate for the exact marking.

CoriolisMaster FCB430, FCB450, FCH430, FCH450

Coriolis mass flowmeter

cFMus

Model number and brief description in Division 2

FCa4c – F2Y0fghijD Integral mount design with dual-compartment housing.

FCa4c – F2efghijY Sensor in remote mount design with dual-compartment housing.

Designed as "Single Seal Device" or as "Dual Seal Device" (option TE2) in accordance with ANSI / ISA 12.27.01.

FCT4c – F2R Transmitter in remote mount design with dual-compartment housing.

Ex-marking

NI: CL I,II,III Div 2, GPS ABCDEFG, T6...T1

DIP: CL II,III, Div 1, GPS EFG, T6

CL I, ZN 2, AEx nA IIC T6...T1

ZN 21, AEx ia tb IIIC T80°C

CL I, ZN 2, Ex nA IIC T6...T1

ZN 21, Ex ia tb IIIC T80°C

See handbook for temperature class information

Certificate

cFMus: 3050239

Model number and brief description in Division 1

FCa4c – F1Y0fghijDx (x = 1 ... 4) Integral mount design with dual-compartment housing.

FCa4c – F1Y0fghijDx (x = 5 ... 8) Integral mount design with dual-compartment housing (Explosionproof "XP").

Designed as "Single Seal Device" or as "Dual Seal Device" (option TE2) in accordance with ANSI / ISA 12.27.01.

XP-IS: CL I, Div 1, GPS ABCD,T6...T1 (USA)

XP-IS: CL I, Div 1, GPS BCD,T6...T1 (CAN)

DIP: CL II,III, Div 1, GPS EFG,T6

ZN 21, AEx ia tb IIIC T80°C

CL I, ZN 1, AEx d ia IIC T6...T1

ZN 21, Ex ia tb IIIC T80°C

CL I, ZN 1, Ex d ia IIB+H2 T6...T1

See handbook for temperature class information and installation drawing 3KXF000028G0009

FCa4c – F1efghijY Sensor in remote mount design with dual-compartment housing.

Designed as "Single Seal Device" or as "Dual Seal Device" (option TE2) in accordance with ANSI / ISA 12.27.01.

XP-IS: CL I, Div 1, GPS BCD T6...T1

DIP: CL II,III, Div 1, GPS EFG,T6

CL I, ZN 1, AEx d ia IIB+H2 T6...T1

ZN 21, AEx ia tb IIIC T80°C

CL I, ZN 1, Ex d ia IIB+H2 T6...T1

ZN 21, Ex ia tb IIIC T80°C

See handbook for temperature class information and installation drawing 3KXF000028G0009

FCT4c – F1Rx (x = 1 ... 4) Transmitter in remote mount design with dual-compartment housing.

FCT4c – F1Rx (x = 5 ... 8) Transmitter in remote mount design with dual-compartment housing (Explosionproof "XP").

XP-IS: CL I, Div 1, GPS BCD,T6...T1 (USA)

XP-IS: CL I, Div 1, GPS BCD,T6...T1 (CAN)

DIP: CL II,III, Div 1, GPS EFG, T6

ZN 21, AEx ia tb IIIC T80°C

CL I, ZN 1, AEx d ia IIB+H2 T6...T1

ZN 21, Ex ia tb IIIC T80°C

CL I, ZN 1, Ex d ia IIB+H2 T6...T1

See handbook for temperature class information and installation drawing 3KXF000028G0009

Certificate

cFMus: 3050239

NOTICE

- Depending on the design, a specific marking in accordance with FM applies.
- ABB reserves the right to modify the Ex-marking. Refer to the name plate for the exact marking.

Temperature data

Temperature resistance for the connecting cable

The temperature at the cable entries of the device is dependent on the measuring medium temperature T_{medium} and the ambient temperature $T_{\text{amb.}}$.

For the electrical connection of the device, use only cables with sufficient temperature resistance according to the following table.

Devices in integral mount design	
$T_{\text{amb.}}$	Temperature resistance
$\leq 50\text{ °C}$ ($\leq 122\text{ °F}$)	$\geq 60\text{ °C}$ ($\geq 140\text{ °F}$)
$\leq 60\text{ °C}$ ($\leq 140\text{ °F}$)	$\geq 70\text{ °C}$ ($\geq 158\text{ °F}$)
$\leq 70\text{ °C}$ ($\leq 158\text{ °F}$)	$\geq 80\text{ °C}$ ($\geq 176\text{ °F}$)

Devices in remote mount design

$T_{\text{amb.}}$	Temperature resistance
$\leq 50\text{ °C}$ ($\leq 122\text{ °F}$)	$\geq 70\text{ °C}$ ($\geq 158\text{ °F}$)
$\leq 60\text{ °C}$ ($\leq 140\text{ °F}$)	$\geq 80\text{ °C}$ ($\geq 176\text{ °F}$)
$\leq 70\text{ °C}$ ($\leq 158\text{ °F}$)	$\geq 90\text{ °C}$ ($\geq 194\text{ °F}$)

In case of remote systems, at $T_{\text{amb.}} \geq 60\text{ °C}$ (140 °F) the cable leads within the connection box of the sensor have to be insulated with supplied silicon tubes.

Sensor in remote mount design

Environmental and process conditions for model FCx4xx...

Ambient temperature $[T_{\text{amb.}}]$	$[T_{\text{amb. optional}}]$	Measuring medium temperature $[T_{\text{medium}}]$	IP rating / NEMA rating
-20 ... 70 °C (-4 ... 158 °F)	-40 ... 70 °C (-40 ... 158 °F)	-40 ... 205 °C (-40 ... 400 °F)	IP 65, IP 67, IP 68 and NEMA 4X / type 4X

Measuring medium temperature (Ex data) for model FCx4xx-A1... in Zone 1, Division 1

Ambient temperature $[T_{\text{amb.}}]$	$\leq 30\text{ °C}$ ($\leq 86\text{ °F}$)	$\leq 40\text{ °C}$ ($\leq 104\text{ °F}$)	$\leq 50\text{ °C}$ ($\leq 122\text{ °F}$)	$\leq 60\text{ °C}$ ($\leq 140\text{ °F}$)	$\leq 70\text{ °C}$ ($\leq 158\text{ °F}$)
Temperature class	Maximum permissible measuring medium temperature $[T_{\text{medium}}]$				
T1	205 °C (400 °F)	205 °C (400 °F)	205 °C (400 °F)	205 °C (400 °F)	205 °C (400 °F)
T2	205 °C (400 °F)	205 °C (400 °F)	205 °C (400 °F)	205 °C (400 °F)	205 °C (400 °F)
T3	195 °C (383 °F)	195 °C (383 °F)	195 °C (383 °F)	195 °C (383 °F)	195 °C (383 °F)
T4	130 °C (266 °F)	130 °C (266 °F)	130 °C (266 °F)	130 °C (266 °F)	130 °C (266 °F)
T5	95 °C (203 °F)	95 °C (203 °F)	95 °C (203 °F)	95 °C (203 °F)	95 °C (203 °F)
T6	80 °C (176 °F)	80 °C (176 °F)	80 °C (176 °F)	80 °C (176 °F)	—

Measuring medium temperature (Ex data) for model FCx4xx-A2... in Zone 2, Division 2

Ambient temperature $[T_{\text{amb.}}]$	$\leq 30\text{ °C}$ ($\leq 86\text{ °F}$)	$\leq 40\text{ °C}$ ($\leq 104\text{ °F}$)	$\leq 50\text{ °C}$ ($\leq 122\text{ °F}$)	$\leq 60\text{ °C}$ ($\leq 140\text{ °F}$)	$\leq 70\text{ °C}$ ($\leq 158\text{ °F}$)
Temperature class	Maximum permissible measuring medium temperature $[T_{\text{medium}}]$				
T1	205 °C (400 °F)	205 °C (400 °F)	205 °C (400 °F)	205 °C (400 °F)	205 °C (400 °F)
T2	205 °C (400 °F)	205 °C (400 °F)	205 °C (400 °F)	205 °C (400 °F)	205 °C (400 °F)
T3	195 °C (383 °F)	195 °C (383 °F)	195 °C (383 °F)	195 °C (383 °F)	195 °C (383 °F)
T4	130 °C (266 °F)	130 °C (266 °F)	130 °C (266 °F)	130 °C (266 °F)	130 °C (266 °F)
T5	95 °C (203 °F)	95 °C (203 °F)	95 °C (203 °F)	—	—
T6	80 °C (176 °F)	—	—	—	—

CoriolisMaster FCB430, FCB450, FCH430, FCH450

Coriolis mass flowmeter

Sensor in integral mount design

Environmental and process conditions for model FCx4xx...

Ambient temperature [T _{amb}]	[T _{amb, optional}]	Measuring medium temperature [T _{medium}]	IP rating / NEMA rating
-20 ... 70 °C (-4 ... 158 °F)	-40 ... 70 °C (-40 ... 158 °F)	-40 ... 205 °C (-40 ... 400 °F)	IP 65, IP 67, and NEMA 4X / type 4X

Measuring medium temperature (Ex data) for model FCx4xx-A1... in Zone 1, Division 1

Ambient temperature [T _{amb}]	≤ 30 °C (≤ 86 °F)	≤ 50 °C (≤ 122 °F)	≤ 60 °C (≤ 140 °F)	≤ 65 °C (≤ 149 °F)	≤ 70 °C ¹⁾ (≤ 158 °F ¹⁾)
Temperature class	Maximum permissible measuring medium temperature [T _{medium}]				
T1	205 °C (400 °F)	205 °C (400 °F)	205 °C (400 °F)	205 °C (400 °F)	205 °C (400 °F)
T2	205 °C (400 °F)	205 °C (400 °F)	205 °C (400 °F)	205 °C (400 °F)	205 °C (400 °F)
T3	195 °C (383 °F)	195 °C (383 °F)	195 °C (383 °F)	195 °C (383 °F)	195 °C (383 °F)
T4	130 °C (266 °F)	130 °C (266 °F)	130 °C (266 °F)	130 °C (266 °F)	130 °C (266 °F)
T5	95 °C (203 °F)	95 °C (203 °F)	95 °C (203 °F)	95 °C (203 °F)	95 °C (203 °F)
T6	80 °C (176 °F)	80 °C (176 °F)	80 °C (176 °F)	80 °C (176 °F)	80 °C (176 °F)

Measuring medium temperature (Ex data) for model FCx4xx-A2... in Zone 2, Division 2

Ambient temperature [T _{amb}]	≤ 30 °C (≤ 86 °F)	≤ 40 °C (≤ 104 °F)	≤ 50 °C (≤ 122 °F)	≤ 60 °C (≤ 140 °F)	≤ 70 °C (≤ 158 °F)
Temperature class	Maximum permissible measuring medium temperature [T _{medium}]				
T1	205 °C (400 °F)	205 °C (400 °F)	205 °C (400 °F)	205 °C (400 °F)	205 °C (400 °F)
T2	205 °C (400 °F)	205 °C (400 °F)	205 °C (400 °F)	205 °C (400 °F)	205 °C (400 °F)
T3	195 °C (383 °F)	195 °C (383 °F)	195 °C (383 °F)	195 °C (383 °F)	195 °C (383 °F)
T4	130 °C (266 °F)	130 °C (266 °F)	130 °C (266 °F)	130 °C (266 °F)	130 °C (266 °F)
T5	95 °C (203 °F)	95 °C (203 °F)	—	—	—
T6	80 °C (176 °F)	—	—	—	—

Electrical data

Standard / No explosion protection	Zone 2 , 21 Division 2 and Zone 2, 21	Zone 1, 21 (Zone 0) Division 2 and Zone 1, 21
ATEX: — IECEX: —	ATEX: II 3 G & II 2 D IECEX: Gc & Db	ATEX: II 1/2 (1) G & II 2 (1) D II 1/2 G & II 2 D II 2 (1) G & II 2 (1) D IECEX: (Ga) Gb & (Da) Db Ga/Gb & Db (Ga) Gb & (Da) Db
USA: — Canada: —	USA: NI & DIP AEx nA & AEx tb Canada: Non-Incendive & Dust Ignition Proof Ex nA & Ex tb	USA: XP-IS & DIP AEx d ia & AEx ia tb Canada: XP-IS & DIP Ex d ia & Ex ia tb

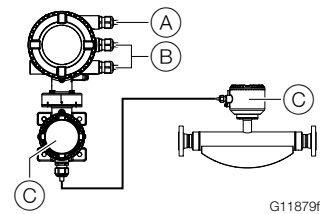
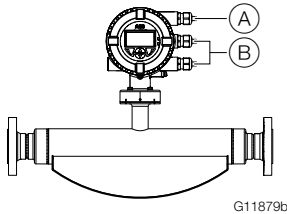

(A) Power supply

- Type of protection ATEX / IECEX: Increased safety "Ex e"
- Type of protection USA / Canada: "non IS"
- Maximum 250 Vrms
- Terminals: 1+, 2-, L, N,

(B) Inputs / outputs, communication

- Type of protection ATEX / IECEX: Either increased safety "Ex e" or intrinsically safe "Ex ia"
- Type of protection USA / Canada: Either "non IS" or "Intrinsic Safety IS".
- When installing in "Ex ia" or "IS", suitable intrinsically safe isolation amplifiers must be used for the connection.
- Terminals: 31, 32, Uco, V1, V2, V3, V4, 41, 42, 51, 52

(C) Signal cable (remote mount design only)

- Terminals: A, B, UFE, GRN
- Type of protection ATEX / IECEX: Increased safety "Ex e"
- Type of protection USA / Canada: "non IS"

NOTICE

When installing in "Ex ia" or "IS", the type of protection is determined by the type of electrical connection. Chapter "Changing the type of protection" in the operating instructions must be observed when changing the type of protection!

CoriolisMaster FCB430, FCB450, FCH430, FCH450

Coriolis mass flowmeter

Zone 2, 21 and Division 2

Model: FCx4xx-A2, FCx4xx-F2				
Outputs on basic device	Operating values (general)		Type of protection – "nA" / "NI"	
	U_N	I_N	U_N	I_N
Active current / HART output 31 / U_{CO} Terminals 31 / U_{CO}	30 V	30 mA	30 V	30 mA
Passive current / HART output 31 / 32 Terminals 31 / 32	30 V	30 mA	30 V	30 mA
Active digital output 41 / 42¹⁾ Terminals 41 / 42 and V1 / V2 ¹⁾	30 V	30 mA	30 V	30 mA
Passive digital output 41 / 42 Terminals 41 / 42	30 V	25 mA	30 V	25 mA
Active digital output 51 / 52¹⁾ Terminals 51 / 52 and V1 / V2 ¹⁾	30 V	30 mA	30 V	30 mA
Passive digital output 51 / 52 Terminals 51 / 52	30 V	30 mA	30 V	30 mA

All outputs are electrically isolated from each other and from the power supply.

Digital outputs 41 / 42 and 51 / 52 are not electrically isolated from each other. Terminals 42 / 52 have the same potential.

Model: FCx4xx-A2, FCx4xx-F2				
Inputs and outputs with plug-in cards	Operating values (general)		Type of protection – "nA" / "NI"	
	U_N	I_N	U_N	I_N
Active current output V3 / V4¹⁾ Terminals V3 / V4 and V1 / V2 ¹⁾	30 V	30 mA	30 V	30 mA
Passive current output V1 / V2²⁾	30 V	30 mA	30 V	30 mA
Passive current output V3 / V4²⁾ Terminals V1 / V2 ²⁾ or V3 / V4 ²⁾	30 V	30 mA	30 V	30 mA
Active digital output V3 / V4¹⁾ Terminals V3 / V4 and V1 / V2 ¹⁾	30 V	25 mA	30 V	25 mA
Passive digital output V1 / V2²⁾	30 V	30 mA	30 V	30 mA
Passive digital output V3 / V4²⁾ Terminals V1 / V2 ²⁾ or V3 / V4 ²⁾	30 V	30 mA	30 V	30 mA
Active digital input V3 / V4¹⁾ Terminals V3 / V4 and V1 / V2	30 V	3.45 mA	30 V	3.45 mA
Passive digital input V1 / V2²⁾	30 V	3.45 mA	30 V	3.45 mA
Passive digital input V3 / V4²⁾ Terminals V1 / V2 ²⁾ or V3 / V4 ²⁾	30 V	3.45 mA	30 V	3.45 mA

1) Only in conjunction with additional "24 V DC power supply (blue)" plug-in card in slot OC1.

2) The terminal assignment depends on the model number or the slot assignment. For connection examples, see chapter "Connection examples" on page 61.

Zone 1, 21 and Division 1

Model: FCx4xx-A1, FCx4xx-F1	Type of protection													
	„e“ / „XP“		„ia“ / „IS“											
Outputs on basic device	U _M [V]	I _M [A]	U _O [V]	U _I [V]	I _O [mA]	I _I [mA]	P _O [mW]	P _I [mW]	C _O [nF]	C _I [nF]	C _{OPA} [nF]	C _{IPA} [nF]	L _O [mH]	L _I [mH]
Active current / HART output 31 / U_{CO} Terminals 31 / U _{CO}	30	0.2	30	30	115	115	815	815	10	10	5	5	0.08	0.08
Passive current / HART output 31 / 32 Terminals 31 / 32	30	0.2	—	30	—	115	—	815	—	27	—	5	0.08	0.08
Active digital output 41 / 42¹⁾ Terminals 41 / 42 and V1 / V2 ¹⁾	30	0.1	27.8	30	119	30	826	225	20	20	29	29	0.22	0.22
Passive digital output 41 / 42 Terminals 41 / 42	30	0.1	—	30	—	30	—	225	—	27	—	5	—	0.08
Active digital output 51 / 52¹⁾ Terminals 51 / 52 and V1 / V2 ¹⁾	30	0.1	27.8	30	119	30	826	225	20	20	29	29	0.22	0.22
Passive digital output 51 / 52 Terminals 51 / 52	30	0.1	—	30	—	30	—	225	—	27	—	5	—	0.08

All outputs are electrically isolated from each other and from the power supply.

Digital outputs 41 / 42 and 51 / 52 are not electrically isolated from each other. Terminals 42 / 52 have the same potential.

Model: FCx4xx-A1, FCx4xx-F1	Type of protection													
	„e“ / „XP“		„ia“ / „IS“											
Inputs and outputs with plug-in cards	U _M [V]	I _M [A]	U _O [V]	U _I [V]	I _O [mA]	I _I [mA]	P _O [mW]	P _I [mW]	C _O [nF]	C _I [nF]	C _{OPA} [nF]	C _{IPA} [nF]	L _O [mH]	L _I [mH]
Active current output V3 / V4¹⁾ Terminals V3 / V4 and V1 / V2 ¹⁾	30	0.1	27.8	30	119	30	826	225	29	29	117	117	0.4	0.4
Passive current output V1 / V2²⁾ Passive current output V3 / V4²⁾ Terminals V1 / V2 ²⁾ or V3 / V4 ²⁾	30	0.1	—	30	—	68	—	510	—	45	—	59	—	0.27
Active digital output V3 / V4¹⁾ Terminals V3 / V4 and V1 / V2 ¹⁾	30	0.1	27.8	30	119	68	826	225	17	17	31	31	0.4	0.4
Passive digital output V1 / V2²⁾ Passive digital output V3 / V4²⁾ Terminals V1 / V2 ²⁾ or V3 / V4 ²⁾	30	0.1	—	30	—	30	—	225	—	13	—	16	—	0.27
Active digital input V3 / V4¹⁾ Terminals V3 / V4 and V1 / V2	30	0.1	27.8	30	119	3.45	826	25.8	17	17	31	31	0.4	0.4
Passive digital input V1 / V2²⁾ Passive digital input V3 / V4²⁾ Terminals V1 / V2 ²⁾ or V3 / V4 ²⁾	30	0.1	—	30	—	3.45	—	25.8	—	13	—	16	—	0.27

1) Only in conjunction with additional "24 V DC power supply (blue)" plug-in card in slot OC1.

2) The terminal assignment depends on the model number or the slot assignment. For connection examples, see chapter "Connection examples" on page 61.

CoriolisMaster FCB430, FCB450, FCH430, FCH450

Coriolis mass flowmeter

Special connection conditions

NOTICE

The AS plug-in card (24 V DC power supply) must only be used to power the internal inputs and outputs on the device. It must not be used to power external circuits!

NOTICE

If the protective conductor (PE) is connected in the flowmeter's terminal box, you must ensure that no dangerous potential difference can arise between the protective conductor (PE) and the equipotential bonding (PA) in the hazardous area.

NOTICE

For devices with a power supply of 11 ... 30 V DC, on-site external overvoltage protection must be provided. It must be ensured that the overvoltage is limited to 140 % (= 42 V DC) of the maximum operating voltage.

The output circuits are designed so that they can be connected to both intrinsically-safe and non-intrinsically-safe circuits.

- It is not permitted to combine intrinsically safe and non-intrinsically safe circuits.
- On intrinsically-safe circuits, equipotential bonding must be in place along the entire length of the cable used for the digital outputs.
- The rated voltage of the non-intrinsically safe circuits is $U_M = 30 \text{ V}$.
- Provided that the rated voltage $U_M = 30 \text{ V}$ is not exceeded if connections are established to non-intrinsically safe external circuits, intrinsic safety is preserved.
- When changing the type of ignition protection, chapter "Changing the type of protection" in the operating instructions must be adhered to.

The concept of intrinsic safety allows several approved intrinsically safe devices to be interconnected without additional certification of intrinsic safety, if the relevant installation standards are observed.

Devices connected to the relevant apparatus must not be operated at over 250 Vrms AC or 250 V DC to ground.

Installation in accordance with ATEX or IECEx must comply with the applicable national and international standards and directives.

Installation in the USA or Canada must comply with ANSI / ISA RP 12.6, "Installation of intrinsically safe systems for hazardous (classified) locations", the "National Electrical Code (ANSI / NFPA 70), sections 504, 505" and the "Canadian electrical code (C22.1-02)".

Apparatus connected to the flowmeter must have appropriate explosion protection approval in accordance with the Entity concept.

The apparatus must have intrinsically safe circuits.

The apparatus must be installed and connected in accordance with the relevant manufacturer documentation.

The electrical specifications in chapter "Electrical data" on page 73 must be observed.

Trademarks

® HART is a registered trademark of FieldComm Group, Austin, Texas, USA

® Modbus is a registered trademark of the Modbus Organization

™ Hastelloy C-4 is a Haynes International trademark

™ Hastelloy C-22 is a Haynes International trademark

Questionnaire

Customer:	Date:
Ms. / Mr.:	Department:
Telephone:	Fax:

Measuring medium:	Liquid content:	Gas content:
Flow rate: (min., max., operating point)	kg/h	
Density: (min., max., operating point)	kg/m ³	
Dynamic viscosity: (min., max., operating point)	mPas/cP	
Fluid temperature: (min., max., operating point)	°C	
Ambient temperature	°C	
Pressure: (min., max., operating point)	bar	
Rate of flow:	<input type="checkbox"/> Steady	<input type="checkbox"/> Pulsating
Batch operation:	<input type="checkbox"/> Yes	<input type="checkbox"/> No
Concentration calculation:	<input type="checkbox"/> Yes	<input type="checkbox"/> No
Transmitter design:	<input type="checkbox"/> Integral mount design	<input type="checkbox"/> Remote mount design
Explosion protection:	<input type="checkbox"/> Yes	<input type="checkbox"/> No
Power supply:	<input type="checkbox"/> 100 ... 230 V AC, 50/60 Hz	<input type="checkbox"/> 11 ... 30 V DC
Electrical outputs:	<input type="checkbox"/> Current output I: 0/4 ... 20 mA <input type="checkbox"/> Current output II: 0/4 ... 20 mA <input type="checkbox"/> Current output III: 0/4 ... 20 mA <input type="checkbox"/> Pulse output, active <input type="checkbox"/> Pulse output, passive	Communication: <input type="checkbox"/> HART protocol
Additional specifications:		
Pipeline diameter:mm	
Process connection:	

Notes

Notes

Contact us

ABB Limited

Industrial Automation

Howard Road, St. Neots
Cambridgeshire, PE19 8EU
UK

Tel: +44 (0)870 600 6122

Fax: +44 (0)1480 213 339

Mail: enquiries.mp.uk@gb.abb.com

ABB Inc.

Industrial Automation

125 E. County Line Road
Warminster, PA 18974
USA

Tel: +1 215 674 6000

Fax: +1 215 674 7183

ABB Automation Products GmbH

Industrial Automation

Dransfelder Str. 2
37079 Goettingen
Germany

Tel: +49 551 905-0

Fax: +49 551 905-777

Mail: [vertrieb.messtechnik-
produkte@de.abb.com](mailto:vertrieb.messtechnik-produkte@de.abb.com)

www.abb.com/flow

Note

We reserve the right to make technical changes or modify the contents of this document without prior notice.

With regard to purchase orders, the agreed particulars shall prevail. ABB does not accept any responsibility whatsoever for potential errors or possible lack of information in this document.

We reserve all rights in this document and in the subject matter and illustrations contained therein. Any reproduction, disclosure to third parties or utilization of its contents – in whole or in parts – is forbidden without prior written consent of ABB.

Copyright© 2017 ABB

All rights reserved

3KXF411010R1001



Sales



Service