

Temposonics®

Magnetostrictive, Absolute, Non-contact
Linear-Position Sensors



R-Series Models RP and RH

EtherCAT® Industrial Ethernet Interface

Document Part Number
551074 Revision B

Data Sheet



Model RP Profile-style position sensor



Model RH Rod-style position sensor



FEATURES

- Linear, Absolute Measurement
- LEDs For Sensor Diagnostics
- Superior Accuracy, Resolution down to 1 μm
- Non-Contact Sensing Technology
- Linearity Deviation Less Than 0.01%
- Repeatability Within 0.001%
- Direct EtherCAT Interface, Position + Velocity
- 100 μs Position / Velocity Update Time, Regardless of Overall Stroke Length

BENEFITS

- Rugged Industrial Sensor
- Position + Velocity Measurements For Up to 20 Magnets

APPLICATIONS

- Continuous Operation In Harsh Industrial Conditions
- High Pressure Conditions
- For Accurate, High-Speed, Simultaneous Multi-Position and Velocity Measurements

TYPICAL INDUSTRIES

- Factory Automation
- Fluid Power
- Plastic Injection and Blow Molding
- Material Handling and Packaging

Time-based Magnetostrictive position sensing principle

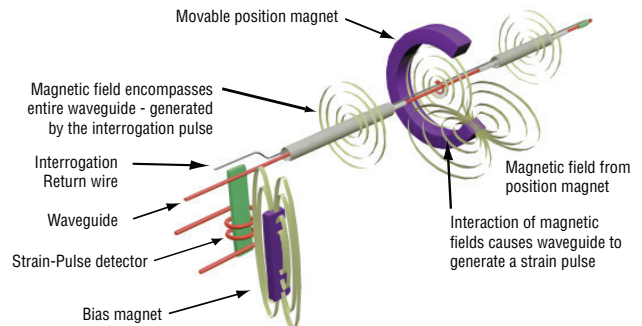

Benefits of Magnetostriction

Temposonics linear-position sensors use the time-based magnetostrictive position sensing principle developed by MTS. Within the sensing element, a sonic-strain pulse is induced in a specially designed magnetostrictive waveguide by the momentary interaction of two magnetic fields. One field comes from a movable permanent magnet that passes along the outside of the sensor. The other field comes from an “interrogation” current pulse applied along the waveguide. The resulting strain pulse travels at sonic speed along the waveguide and is detected at the head of the sensing element.

The position of the magnet is determined with high precision and speed by accurately measuring the elapsed time between the application of the interrogation pulse and the arrival of the resulting strain pulse with a high-speed counter. The elapsed time measurement is directly proportional to the position of the permanent magnet and is an absolute value. Therefore, the sensor's output signal corresponds to absolute position, instead of incremental, and never requires recalibration or re-homing after a power loss. Absolute, non-contact sensing eliminates wear, and guarantees the best durability and output repeatability.

Product Overview and Specifications

Product overview

Temposonics R-Series EtherCAT sensors represent MTS Sensors' development and product offering in high-speed networked position feedback. EtherCAT (Ethernet for Control Automation Technology) is a unique interface developed by Beckhoff Automation and is supported by the EtherCAT Technology Group (ETG).

This interface is used for industrial Ethernet, providing the fastest, most deterministic industrial networking solution possible using the base Ethernet physical layer. By using this format, coupled with our high speed networked sensing capability, machine builders and automation engineers will be able to overcome bandwidth and node limitation issues found with other commercially available industrial networks.

Product specifications

Parameters	Specifications
OUTPUT	
Measured output variables:	Simultaneous multi-position and velocity measurements up to 20 magnets or up to 5 magnets when using high-speed update (for EtherCAT distributed clock mode). Option for acceleration measurements up to 2 magnets.
Resolution:	1 to 1000 µm selectable
Update time:	100 µs min. (high speed update feature is active when the controller's loop time is less than the sensor's measurement cycle time)
Linearity deviation:	< ± 0.01% full stroke (minimum ± 50 µm) (Linearity Correction Option (LCO) available)
Repeatability:	< ± 0.001% full stroke (minimum ± 2.5 µm)
Hysteresis:	< 4 µm
Outputs:	Interface: EtherCAT Data format: EtherCAT 100 Base-Tx, fast Ethernet Data transmission rate: 100 Mbit/s max.
Stroke length:	Range (Profile style): 25 mm to 5080 mm (1 in. to 200 in.) Range (Rod style): 25 mm to 7620 mm (1 in. to 300 in.)
ELECTRONICS	
Operating voltage:	+24 Vdc nominal: -15% or +20%* Polarity protection: up to -30 Vdc Over voltage protection: up to 36 Vdc Current drain: 80 mA typical Dielectric withstand voltage: 500 Vdc (DC ground to machine ground)

Parameters	Specifications
ENVIRONMENTAL	
Operating conditions:	Operating temperature: 0 °C (32 °F) to +75 °C (+167 °F) Relative humidity: 90% no condensation Temperature coefficient: < 15 ppm/ °C
EMC test:	Electromagnetic emission: IEC/EN 50081-1 Electromagnetic susceptibility: IEC/EN 50082-2, IEC/EN 61000-4-2/3/4/6, level 3/4 criterium A, CE qualified
Shock rating:	100 g (single hit)/IEC standard 68-2-27 (survivability)
Vibration rating:	15 g / 10 to 2000 Hz / IEC standard 68-2-6
WIRING	
Connection type:	D56 option: Two female 4-pin (M12-D) plus one 4-pin male (M8) connector
PROFILE STYLE SENSOR (MODEL RP)	
Electronic head:	Aluminum housing with diagnostic LED display (LEDs located beside connectors)
Sealing:	IP 65**
Sensor extrusion:	Aluminum (Temposonics profile style)
Mounting:	Any orientation. Adjustable mounting feet or T-slot nut (M5 threads) in bottom groove
Magnet types:	Captive-sliding magnet or open-ring magnet
ROD STYLE SENSOR (MODEL RH)	
Electronic head:	Aluminum housing with diagnostic LED display (LEDs located beside connectors)
Sealing:	IP 67**
Sensor rod:	304L stainless steel
Operating pressure:	350 bar static, 690 bar peak (5000 psi static, 10,000 psi peak)
Mounting:	Any orientation. Threaded flange M18 x 1.5 or 3/4 - 16 UNF-3A
Typical mounting torque:	45 N-m (33 ft. - lbs.)
Magnet types:	Ring magnet, open-ring magnet, or magnet float

* UL Recognition requires an approved power supply with energy limitation UL 61010-1), or Class 2 rating according to the National Electrical Code (USA) / Canadian Electrical Code.

** The IP rating is not part of the UL Recognition.

Enhanced monitoring and diagnostics

SENSOR STATUS AND DIAGNOSTIC DISPLAY



Integrated diagnostic LEDs (green/red), located beside sensor connectors (see 'Figure 1'), provide basic visual monitoring for normal sensor operation and troubleshooting. Diagnostic display LEDs indicate four modes described in 'Table 1. Diagnostic display indicator modes'

Figure 1. R-Series sensor Integrated diagnostic LEDs

Status LED (Green)	Off: On: Flashing:	Initializing Normal function Various flashing codes show different operational status
Error LED (Red)	Off: On: Flashing:	Normal function missing magnet Supply voltage beyond limits (high or low)
IN Port LED (Green)	Off: On: Flashing:	No link Link detected Traffic
OUT Port LED (Green)	Off: On: Flashing:	No link Link detected Traffic

Table 1. Diagnostic display indicator modes

EtherCAT interface

EtherCAT is an open field bus system which is based on Ethernet technology, (IEEE 802.3), with a high data rate and short response time, resulting in very good real-time performance. It is standardized in the IEC/PAS 62407 and is part of the ISO 15745-4 standard. The EtherCAT protocol is also being integrated into the IEC 61158, IEC 61784, and IEC 61800-7 standards.

The Temposonics EtherCAT sensor is connected as a slave device, and as such, fulfils all the requirements of the EtherCAT field bus system. Adding the sensor to an EtherCAT bus system is very easy. The system manager (e.g. TwinCAT from Beckhoff Automation) gets all the parameters of the sensor from the XML file, available from the MTS website at <http://www.mtssensors.com>. There are no adjustments necessary on the sensor itself. For some applications, optimum system performance is obtained using the sensor's high speed updates, up to 10 kHz, by synchronizing to the EtherCAT's 'distributed clock mode' (available on the "E101" sensor output option).

Operation modes and output

There are two operation modes available:

E101 - Fast update position and velocity:

- Designed for high-speed motion control
- Up to 5 simultaneous magnet measurements
- 100 μ s update rate, (independent of stroke length)

E102 Multi-magnet position and velocity:

- Designed for gauging systems having many magnet positions
- Up to 20 simultaneous magnet measurements
- Standard update rates, (stroke length dependent)

When using multiple magnets, the minimum allowed distance between magnets is 75 mm (3 in.) to maintain proper sensor output (see 'Figure 2').

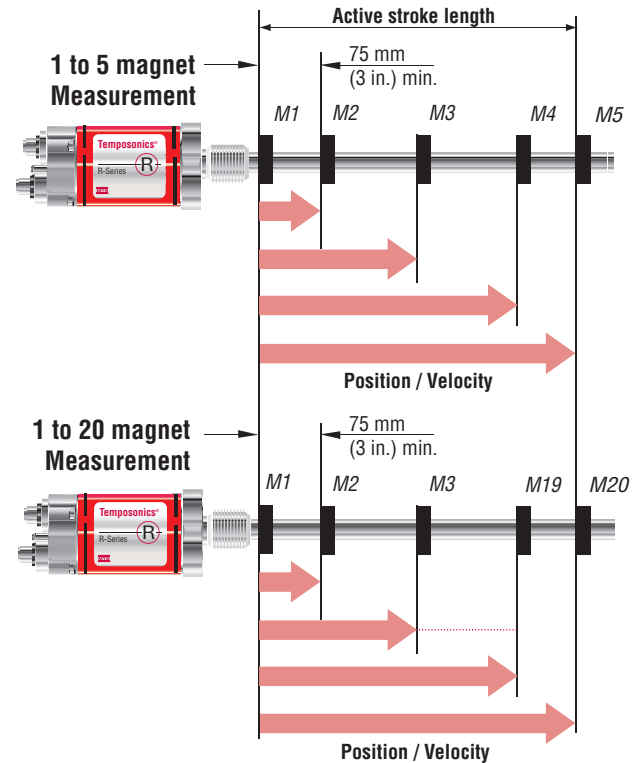

Figure 2. Single to multi-magnet output diagram

LINEARITY CORRECTION OPTION (LCO)

The Linearity Correction Option (LCO) provides improved sensor output accuracy. For most stroke lengths linearity accuracy is improved up to a factor of 5 resulting in deviations from actual position of less than $\pm 20 \mu$ m (0.0008 in.). For stroke lengths over 5000 mm (197 in.), the linearity accuracy is improved up to factor of 10. Selecting the sensor style and magnet is important (both must be matched together). Contact the factory for assistance when designing for the LCO in your application.

Model RP Profile-Style Sensor
Sensor Dimension References

Model RP profile-style sensor dimension references

MODEL RP, PROFILE-STYLE SENSOR WITH CAPTIVE-SLIDING MAGNET Drawing is for reference only, contact applications engineering for tolerance specific information.

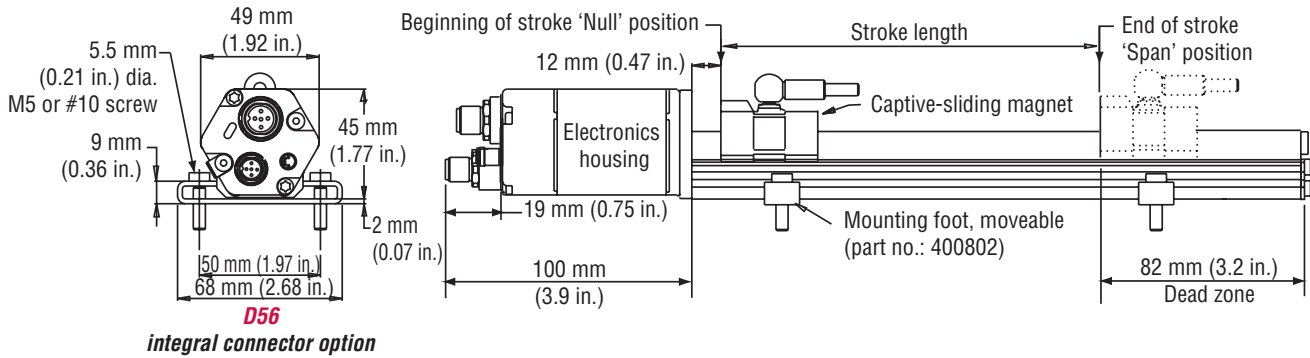

Figure 3. R-Series Model RP Profile-style sensor dimension reference (Shown with the **D56** connector option)

MODEL RP, PROFILE-STYLE SENSOR WITH OPEN-RING MAGNET Drawing is for reference only, contact applications engineering for tolerance specific information.

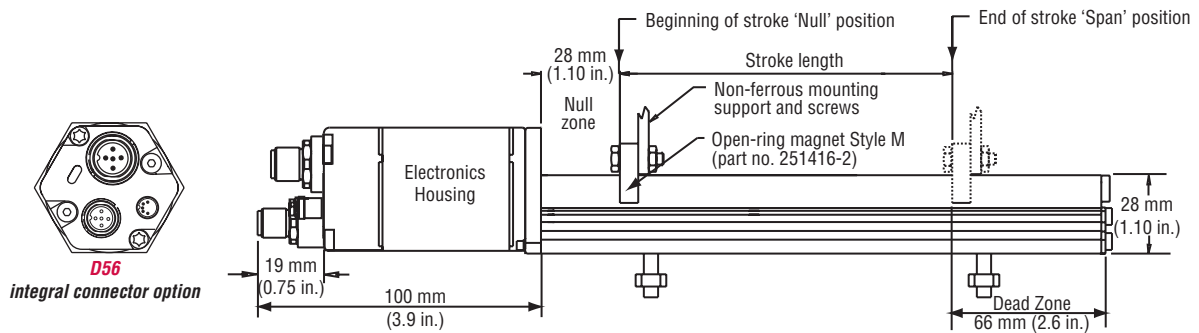

Figure 4. R-Series Model RP Profile-style sensor dimension reference (Shown with the **D56** connector option)

Standard magnet selections (Model RP)

SELECTION OF POSITION MAGNETS (ONE MAGNET INCLUDED WITH MODEL RP SENSOR)

A choice of two magnet mounting configurations are available with the profile-style sensor; A 'captive-sliding' magnet, *Styles S or V* or an 'open-ring' magnet, *Style M*. Captive-sliding magnets utilize slide bearings of special material that reduce friction, and if required, help mitigate dirt build up. The slide bearings are designed to operate dry, requiring no external lubrication or maintenance.

The *Style M* 'open-ring' magnet mounts on the moving machine part and travels just above the sensor's profile extrusion. The open-ring magnet requires a minimum distance away from ferrous metals to allow proper sensor output. It must be mounted using non-ferrous screws and a non-ferrous support bracket, or utilize a non-ferrous spacer of at least 5 mm (0.2 in.) thickness.

POSITION MAGNET SELECTIONS (Drawing dimensions are for reference only)

Magnet dimensions and mounted magnet dimensions	Description	Part number
<p>14 mm (0.55 in.) 43 mm (1.69 in.) 20 mm (0.79 in.) 25 mm (1 in.) 40 mm (1.58 in.) Rotation: Vertical: 18° Horizontal: 360° Ball-jointed arm (M5 thread)</p>	<p>Captive-sliding magnet, Style S For Model RP profile-style sensor</p>	252182
<p>14 mm (0.55 in.) 57 mm (2.24 in.) 25 mm (1 in.) 40 mm (1.58 in.) 9 mm (0.35 in.) Rotation: Vertical: 18° Ball-jointed arm (M5 thread)</p>	<p>Captive-sliding magnet, Style V For Model RP profile-style sensor</p>	252184
Magnet dimensions and mounted magnet dimensions	Description	Part number
<p>60° 14 mm (0.55 in.) 25 mm (0.97 in.) 21 mm (0.81 in.) 2 Holes Each 4.3 mm (0.17 in.) dia. on 24 mm (0.94 in.) dia. Non-ferrous mounting support and screws 21 mm (0.81 in.) 29 mm (1.14 in.) Max gap 3 mm ± 1 mm (0.12 in. ± 0.04 in.) Open-ring magnet Style 'M'</p>	<p>Open-ring magnet, Style M I.D.: 13.5 mm (0.53 in.) O.D.: 33 mm (1.3 in.) Thickness: 8 mm (0.31 in.) Operating temperature: - 40 °C to 100 °C</p> <p>This magnet may influence the sensor performance specifications for some applications.</p>	251416-2

**Model RP Profile-Style Sensor
Sensor Mounting Reference**

Model RP Sensor mounting

Model RP profile-style sensor mounting flexible installation in any position!

Temposonics Model RP profile-style sensors offer two basic mounting methods; side grooves for use with mounting feet or a bottom groove that accepts special T-Slot nuts. Both the mounting feet and T-Slot nuts can be positioned along the sensor extrusion to best secure the sensor for each particular application.

Notes:

1. Model RP sensors include two mounting feet (part no. 400802) for sensors stroke lengths up to 1250 mm (50 in.)
2. One additional mounting foot is included for stroke lengths over 1250 mm (50 in.) and for each additional 500 mm (20 in.), thereafter.
3. MTS recommends using 10-32 cap screws (*customer supplied*) at a maximum torque of 44 in. lbs. when fastening mounting feet.

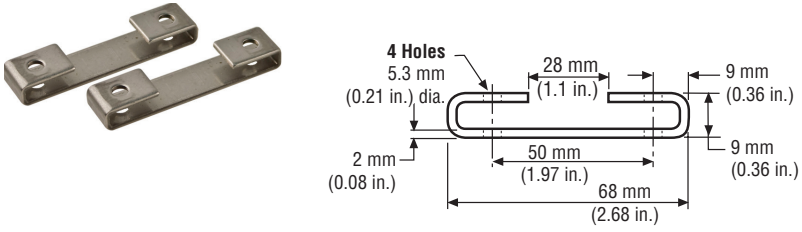
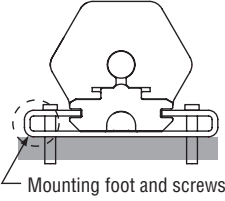
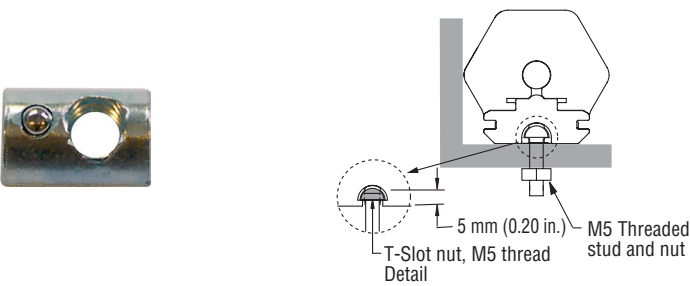
Profile-Style sensor mounting and installation reference	Mounting method	Part number
 <p>(Width = 14.5 mm (0.57 in.))</p>	<p>Mounting feet, standard (304 SS) Profile-style sensor mounting for sensor model RP</p>	<p>400802</p>
<p>10 - 32 Cap screws Recommended (Customer supplied)</p>  <p>Mounting foot and screws</p>	<p>Mounting feet and screws Profile-style sensor foot installation</p>	<p>See Mounting Feet part number: 400802</p>
 <p>T-Slot nut, M5 thread Detail</p> <p>5 mm (0.20 in.)</p> <p>M5 Threaded stud and nut</p>	<p>T-Slot nut Nut for mounting model RP sensor M5 thread (Optional, ordered separately)</p>	<p>401602</p>

Model RH rod-style sensor dimension reference

The Temposonics R-Series rod-style sensor (Model RH) offers modular construction, flexible mounting configurations, and easy installation. The Model RH sensor is designed for mounting in applications where high pressure conditions exist (5000 psi continuous, 10,000 psi spike) such as inside hydraulic cylinders. The Model RH sensor (see 'Figure 5') may also be mounted externally in many applications.

Stroke-dependent Dead Zones:	
Stroke length:	Dead zone:
25 mm (1 in.) - 5000 mm (197 in.)	63.5 mm (2.5 in.)
5005 mm (197 in.) - 7620 mm (300 in.)	66 mm (2.6 in.)

MODEL RH, ROD-STYLE SENSOR WITH RING MAGNET (MAGNET ORDERED SEPARATELY) Drawing is for reference only, contact applications engineering for tolerance specific information.

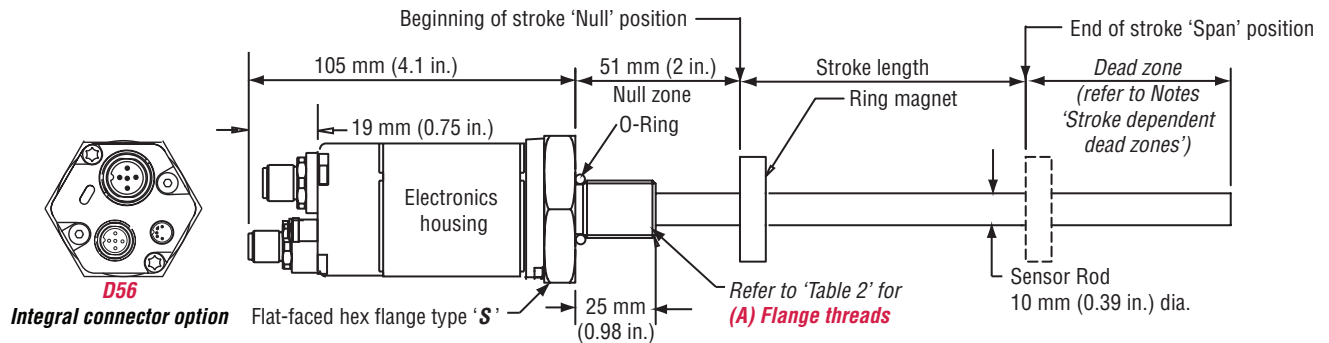

Figure 5. Model RH Rod-style sensor dimension reference (shown with **D56** integral connector options)

MODEL RH, ROD-STYLE SENSOR WITH RING MAGNET (MAGNET ORDERED SEPARATELY)
Drawing is for reference only, contact applications engineering for tolerance specific information.

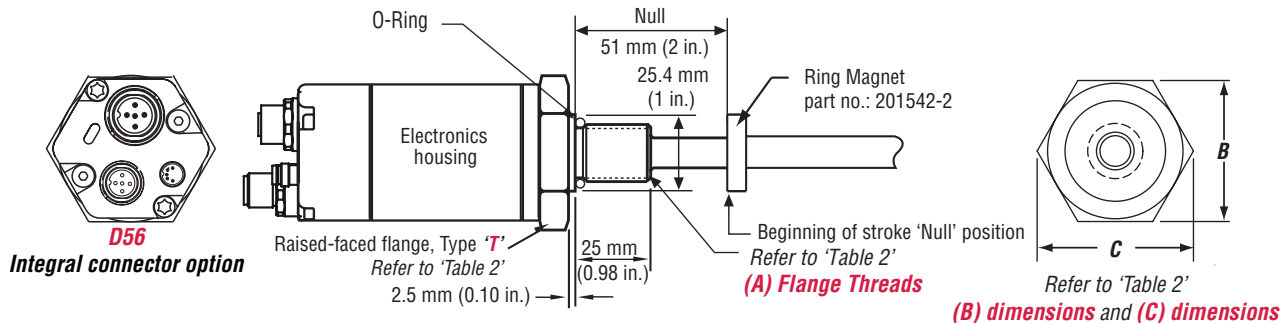

Figure 6. Model RH Rod-style sensor dimension reference (Shown with the **D56** Integral cable connection type option)

Housing style Flange type	Description	(A) Flange threads	(B) Dimensions	(C) Dimensions
T	US customary threads with raised-face flange	3/4" - 16 UNF-3A	1.75 in.	2 in.
S	US customary threads with flat-faced flange	3/4" - 16 UNF-3A	1.75 in.	2 in.
M	Metric threads with flat-faced flange	M18 x 1.5	46 mm	53 mm

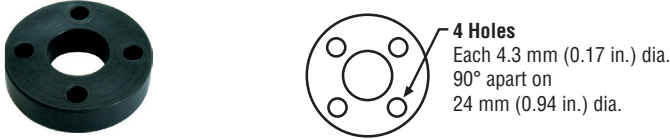
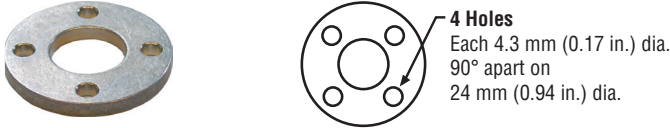

Table 2. Model RH Rod-style sensor housing style and flange type references

**Model RH Rod-Style Sensor
Standard Magnet Selections**

Standard magnet options (Model RH)

Magnets must be ordered separately with Model RH position sensors. The standard ring magnet (part number 201542-2) is suitable for most applications.

POSITION MAGNET SELECTIONS (MAGNET MUST BE ORDERED SEPARATELY) *(Drawing dimensions are for reference only)*

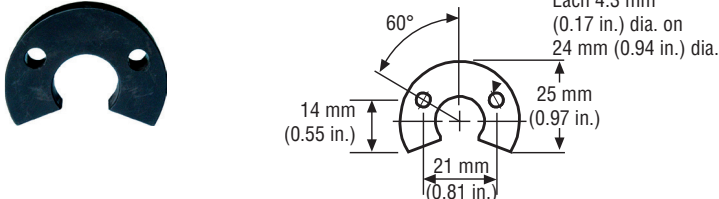
Magnet and magnet dimensions	Description	Part number
	<p>Standard ring magnet I.D.: 13.5 mm (0.53 in.) O.D.: 33 mm (1.3 in.) Thickness: 8 mm (0.3 in.) Operating temperature: - 40 °C to 100 °C</p>	201542-2
	<p>Magnet spacer (Non-ferrous, use with ring magnet Part number: 201542-2) I.D.: 14 mm (0.56 in.) O.D.: 32 mm (1.25 in.) Thickness: 3.2 mm (0.125 in.)</p>	400633
	<p>Ring magnet I.D.: 13.5 mm (0.53 in.) O.D.: 25.4 mm (1 in.) Thickness: 8 mm (0.3 in.) Operating temperature: - 40 °C to 100 °C</p>	400533
	<p>Open-ring magnet, Style M I.D.: 13.5 mm (0.53 in.) O.D.: 33 mm (1.3 in.) Thickness: 8 mm (0.3 in.) Operating temperature: - 40 °C to 100 °C</p> <p>This magnet may influence the sensor performance specifications for some applications.</p>	251416-2

MAGNET FLOAT SELECTION *(Drawing dimensions are for reference only)*

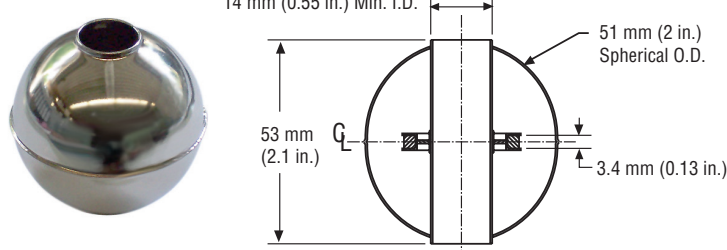
	<p>Magnet float (Level sensing applications) Specific gravity: 0.70 maximum Pressure: 870 psi maximum</p> <p>(This float is used with Model RH rod-style sensors for hydraulic fluid or fresh water applications only). Collar (part no.: 560777) is recommended for end of stroke stops.</p>	251447
---	---	--------

Model RH rod-style sensor mounting

The position magnet requires minimum distances away from ferrous metals to allow proper sensor output. The minimum distance from the front of the magnet to the cylinder end cap is 15 mm (0.6 in.).

The minimum distance from the back of the magnet to the piston head is 3.2 mm (0.125 in.). However, a minimum distance of at least 5 mm (0.197 in.) is preferred for added performance margin. The non-ferrous spacer (part no. 400633), provides this minimum distance when used along with the standard ring magnet (part no.: 201542-2) as shown in *Figure 7*.

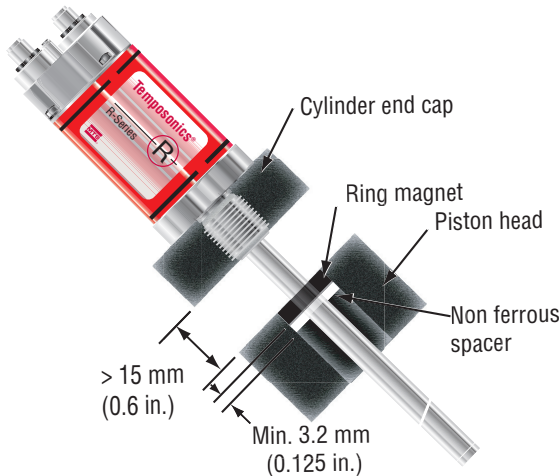

Figure 7. Model RH rod-style mounting

Cylinder installation

When used for direct-stroke measurement in fluid cylinders, the sensor's high pressure, stainless steel rod installs into a bore in the piston head/rod assembly as shown in *Figure 8*. This method guarantees a long-life and trouble-free operation.

The sensor cartridge can be removed from the flange and rod housing while still installed in the cylinder. This procedure allows quick and easy sensor cartridge replacement, without the loss of hydraulic pressure.

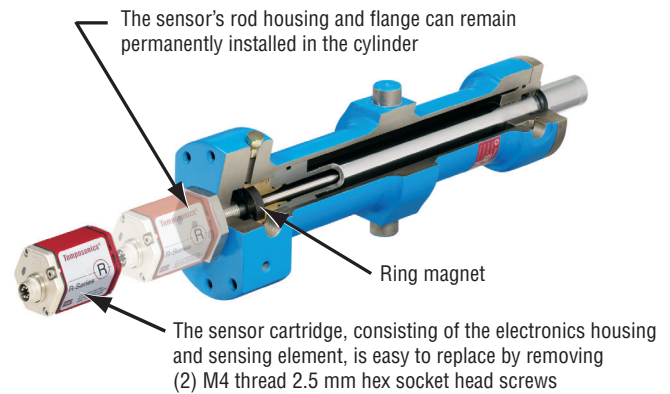
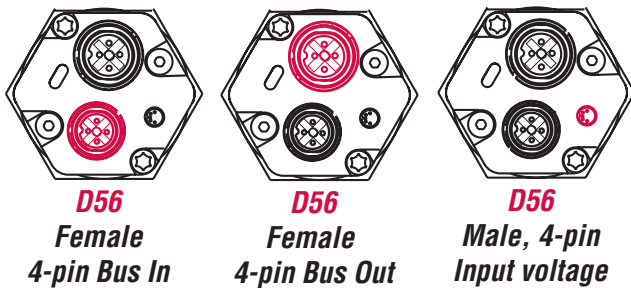

Figure 8. Fluid cylinder installation

Connections and wiring

(D56) BUS CONNECTOR OPTION

D56 connector option for 'daisy chain' topologies. A separate cable is used for the supply voltage. Unused connectors should be covered by a protective cap (part no.: 370537).



BUS CONNECTIONS IN/OUT



Female, 4-pin (M12-D) Integral connector pin-out as viewed from the end of the sensor

Pin number	Cable color	Function
1	Yellow	Tx+
2	White	Rx+
3	Orange	Tx-
4	Blue	Rx-

INPUT VOLTAGE





Input voltage, male, 4-pin (M8) integral connector pin-out as viewed from the end of the sensor

Pin number	Cable color	Supply voltage
1	Brown	+24 Vdc (-15/+20%)
2	White	No connection
3	Blue	DC ground (for supply)
4	Black	No connection

Models RP and RH Sensors
Ordering Information, Connector and Cable Assembly Options

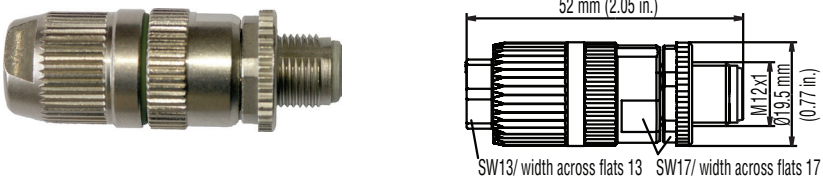
(D56) CABLE CONNECTOR OPTIONS (Drawing dimensions are for reference only)

Connector and connector dimensions	Description	Part number
	<p>Bus Cable Connector, Male 4-pin (M12), D-coded with insulation displacement technology</p>	<p>370523</p>
	<p>Connector, Female 4-pin (M8) and cable with pigtail termination</p> <p>For 24 Vdc input. Wire gage 4x0.25 mm² shielded, PUR cable jacket</p>	<p>5 m length = 530066 10 m length = 530096 15 m length = 530093</p>
	<p>Connector end cap</p> <p>(Unused connectors should be covered by this protective cap)</p>	<p>370537</p>

BUS CABLE WITH CONNECTORS (Drawing dimensions are for reference only)

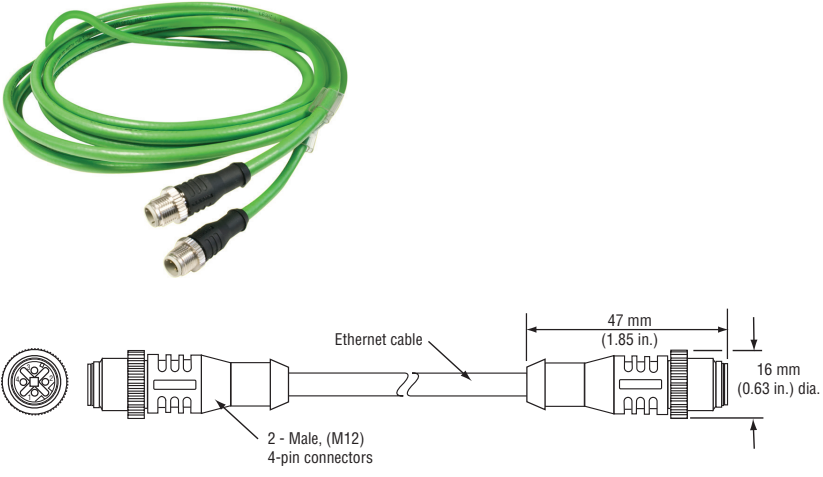
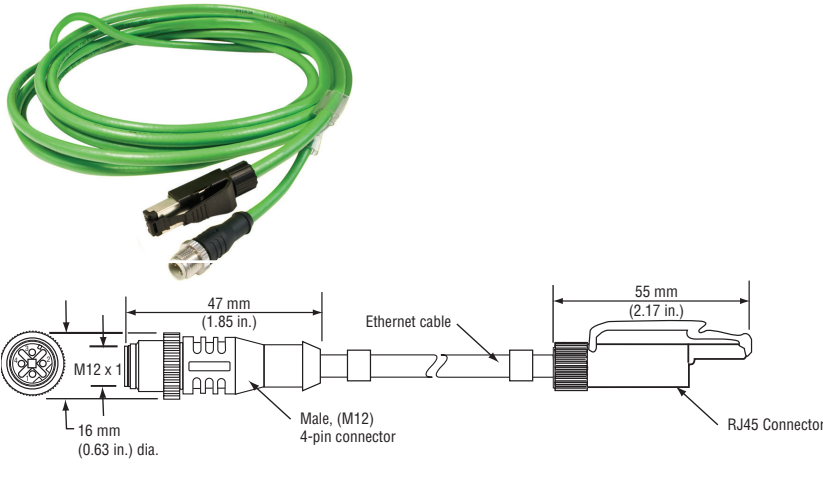
Bus cable and connector assemblies	Description	Part number
	<p>Industrial Ethernet Bus Cable, 5 m length (Cat 5e ES)</p> <p>Assembly Includes two 4-pin (M12) connectors (D-coded) and PUR cable jacket (green)</p>	<p>530064</p>
	<p>Industrial Ethernet Bus Cable, 5 m length (Cat 5e ES)</p> <p>Assembly Includes one RJ45 connector and one 4-pin (M12) connector (D-coded) with PUR cable jacket (green) Cables using the RJ45 connector provide convenient sensor connection to a PC for setup and programming but are not recommended for factory floor installations.</p>	<p>530065</p>

Models RP and RH Sensors
Ordering Information

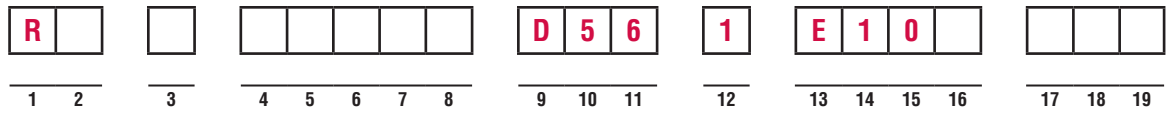

SENSOR MODEL

RP = Profile style

RH = Hydraulic rod style

R 1-2

HOUSING STYLE

Model RP profile-style sensor (includes one magnet):

S = Captive-sliding magnet with ball joint at top (part no. 252182)

V = Captive-sliding magnet with ball joint at front (part no. 252184)

M = Open-ring magnet (part no. 251416-2)

Model RH rod-style sensor (magnet(s) must be ordered separately):

T = US customary threads, raised-faced flange and pressure tube, standard

U = Same as option "T", except uses fluoroelastomer seals for the electronics housing

B = Sensor cartridge only (no flange or pressure tube, stroke length < 1830 mm (72 in.))

S = US customary threads, flat-faced flange and pressure tube, standard

H = Same as option "S", except uses fluoroelastomer seals for the electronics housing

M = Metric threads, flat-faced flange and pressure tube, standard

V = Same as option "M", except uses fluoroelastomer seals for the electronics housing

3

STROKE LENGTH

M = Millimeters
(Encode in 5 mm increments)

U = Inches and tenths
(Encode in 0.1 in. increments)

Stroke Length Notes:

1. Profile-style sensor (model RP) stroke range = 25 mm (1 in.) - 5080 mm. (200 in.)
2. Rod-style sensor (model RH) stroke range = 25 mm (1 in.) - 7620 mm (300 in.)

4-8

CONNECTION TYPE

Integral connector:

D56 = Two 4-pin female (M12-D), plus one 4-pin male (M8)

D 5 6 9-11

INPUT VOLTAGE

1 = +24 Vdc (+20% - 15%)

1 12

OUTPUT

E101 = EtherCAT, position and velocity, high speed updates, maximum 5 magnets

E102 = EtherCAT, position and velocity, maximum 20 magnets

E103 = Same as option 'E101' with Linearity Correction Option (LCO)

E104 = Same as option 'E102' with Linearity Correction Option (LCO)

E 1 0 13-16

NUMBER OF MAGNETS

For multi-position measurement only (Order additional magnets separately).

Z = Number of magnets for output **E101** (range 02 to 05), or for output **E102** (range 02 to 20)

Z 17-19

Document Part number:
551074 Revision B (EN) 05/2014



LOCATIONS

USA
MTS Systems Corporation
Sensors Division
3001 Sheldon Drive
Cary, N.C. 27513, USA
Tel. +1 919 677-0100
Fax +1 919 677-0200
info.us@mtssensors.com
www.mtssensors.com

GERMANY
MTS Sensor Technologie
GmbH & Co. KG
Auf dem Schüffel 9
58513 Lüdenscheid, Germany
Tel. +49 2351 9587-0
Fax +49 2351 56491
info.de@mtssensors.com
www.mtssensor.de

JAPAN
MTS Sensors Technology Corp.
737 Aihara-machi,
Machida-shi,
Tokyo 194-0211, Japan
Tel. +81 42 775-3838
Fax +81 42 775-5512
info.jp@mtssensors.com
www.mtssensor.co.jp

FRANCE
MTS Systems SAS
Zone EUROPARC Bâtiment EXA 16
16/18, rue Eugène Dupuis
94046 Creteil, France
Tel. +33 1 58 4390-28
Fax +33 1 58 4390-03
info.fr@mtssensors.com
www.mtssensor.com

ITALY
MTS Systems Srl. Sensor Division
Via Diaz,4
25050 Provaglio d'Iseo (BS), Italy
Tel. +39 030 988 3819
Fax +39 030 982 3359
info.it@mtssensors.com
www.mtssensor.com

CHINA
MTS Sensors
Room 504, Huajing Commercial Center,
No. 188, North Qinzhou Road
200233 Shanghai, China
Tel. +86 21 6485 5800
Fax +86 21 6495 6329
info.cn@mtssensors.com
www.mtssensors.cn

LEGAL NOTICES

MTS, Temposonics and Level Plus are registered trademarks of MTS Systems Corporation. All other trademarks are the property of their respective owners. Printed in USA. Copyright © 2014 MTS Systems Corporation. All Rights Reserved in all media.

All specifications are subject to change. Contact MTS for specifications and engineering drawings that are critical to your application. Drawings contained in this document are for reference only. Go to <http://www.mtssensors.com> for the latest product information.