ABB MEASUREMENT & ANALYTICS | DATA SHEET

CoriolisMaster FCB400, FCH400

Coriolis mass flowmeter



Measurement made easy

High-precision measurement of mass and volume flow, density, temperature and concentration with just one device

Up to five modular I/Os

- Optional plug-in cards
- Automatic firmware update
- Integrated solutions for filling operations and concentration measurement

SmartSensor

- All digital solution
- Measuring device intelligence located directly in the sensor
- Lower pressure loss

Integrated VeriMass device verification and diagnosis

- Predictive maintenance in the process
- Extended maintenance cycles
- Reduced maintenance effort

Overview – models

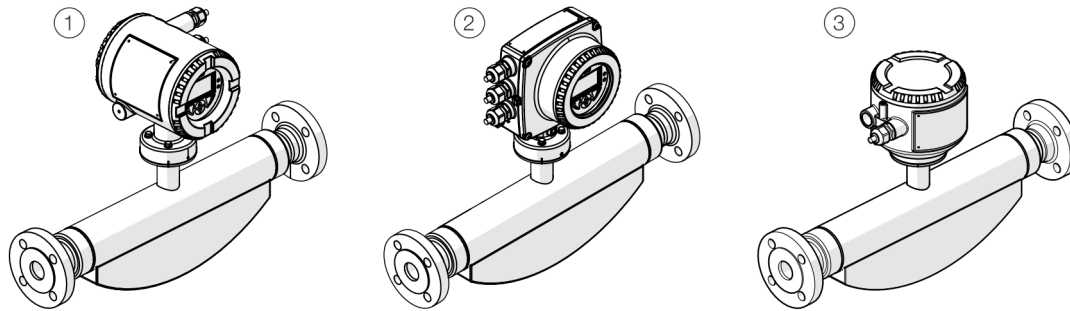

① Sensor (integral mount design, dual-compartment housing)

② Sensor (integral mount design, single-compartment housing)

③ Sensor (remote mount design)

Figure 1: Designs

Sensor				
Model	FCB400 standard design		FCH400 hygienic design	
Housing	Integral mount design, remote mount design			
Measuring accuracy for liquids	FCB430	FCB450	FCH430	FCH450
Mass flow*	0.4 %, 0.25 % and 0.2 %	0.1 % and 0.15 %	0.4 %, 0.25 % and 0.2 %	0.1 % and 0.15 %
Volume flow*	0.4 %, 0.25 % and 0.2 %	0.15 % and 0.11 %	0.4 %, 0.25 % and 0.2 %	0.15 % and 0.11 %
Density	0.01 kg/l	<ul style="list-style-type: none"> • 0.002 kg/l • 0.001 kg/l (optional) • 0.0005 kg/l 	0.01 kg/l	<ul style="list-style-type: none"> • 0.002 kg/l • 0.001 kg/l (optional) • 0.0005 kg/l
Temperature	1 K	0,5 K	1 K	0,5 K
Measuring accuracy for gases*	1 %	0,5 %	1 %	0,5 %
Permissible measuring medium temperature T_{medium}	-50 to 160 °C (-58 to 320 °F)	-50 to 205 °C (-58 to 400 °F)	-50 to 160 °C (-58 to 320 °F)	-50 to 205 °C (-58 to 400 °F)
Process connection				
Flange DIN 2501 / EN 1092-1	DN 10 to 200; PN 40 to PN 160		—	
Flange ASME B16.5	DN ½ to 8 in; CL150 to CL1500		—	
JIS flange	DN 10 to 200; JIS 10K to 20K		—	
Pipe fitting DIN 11851	DN 10 to 100 (¾ to 4 in)		DN 20 to 100 (½ to 4 in)	
Pipe fitting SMS 1145	DN 25 to 80 (1 to 3 in)		—	
Tri-clamp DIN 32676 (ISO 2852)	DN 15 to 100 (¼ to 4 in)		DN 20 to 100 (¼ to 4 in)	
Tri-clamp BPE	DN ¾ to 4 in		DN ¾ to 4 in	
Female thread DIN ISO 228 and ASME B 1.20.1	DN 15; PN 100		—	
Other connections	On request		On request	
Wetted material	Stainless steel 1.4435 or 1.4404 (AISI 316L), nickel-alloy C4 / C22 (optional)		Stainless steel, polished 1.4404 (AISI 316L) or 1.4435 (AISI 316L)	
IP rating	<ul style="list-style-type: none"> • Integral mount design: IP 65 / IP 67, NEMA 4X • Remote mount design: IP 65 / IP 67 / IP 68 (sensor only, immersion depth: 5 m), NEMA 4X 			
Approvals				
Explosion protection	ATEX / IECEx / cFMus		ATEX / IECEx / cFMus	
Hygiene approvals	—		EHEDG (optional), FDA compliant	
Legal metrology	Type-tested for legal metrology in accordance with MID / OIML R117 or API / AGA			
Further approvals	At www.abb.com/flow or upon request.			

* Indication of accuracy in % of the measured value

... Overview – models

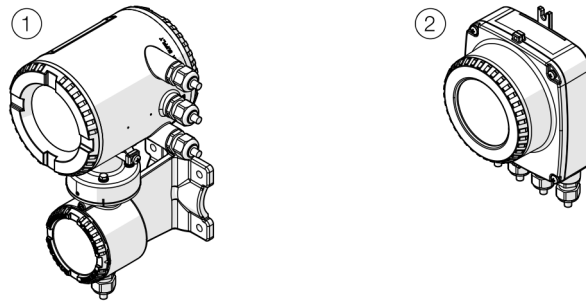

① Dual-compartment housing

② Single-compartment housing

Figure 2: Transmitter with remote mount design

Transmitter	
Chassis	Integral mount design (see Figure 1, pos. ① and ②), remote mount design.
IP rating	IP 65 / IP 67, NEMA 4X
Cable length	Maximum 200 m (656 ft), with remote mount design only
Power supply	100 to 240 V AC, 50 / 60 Hz 11 to 30 V DC, nominal voltage: 24 V DC
Outputs in basic version	Current output: 4 to 20 mA active or passive Digital output 1: passive, configurable as pulse, frequency or switch output Digital output 2: passive, configurable as pulse or switch output
Additional optional outputs	The transmitter has two slots in which plug-in cards can be inserted to provide additional inputs and outputs. The following plug-in cards are available: <ul style="list-style-type: none"> • Current output (maximum two plug-in cards simultaneously) • Digital output (maximum one plug-in card) • Digital input (maximum one plug-in card) • Modbus or PROFIBUS DP interface (maximum of one plug-in card) • 24 V DC loop power supply for active outputs (maximum one plug-in card)
External output zero return	Yes
External totalizer reset	Yes
Forward / reverse flow metering	Yes
Counter	Yes
Communication	HART® protocol 7.1, Modbus® or PROFIBUS DP® (using a plug-in card), EtherNet/IP™, Modbus® TCP, Webservice over Ethernet*
Empty pipe detection	Yes, via configurable density alarm
Self-monitoring and diagnosis	Yes
Local indicator	Yes
Field optimization for flow and density	Yes
Concentration measurement 'DensiMass'	Yes, optional on models FCB450 and FCH450
'FillMass' filling function	Yes, optional on models FCB450 and FCH450
'VeriMass' function	Yes, optional
'Enhanced Coriolis Control (ECC)' function	Yes, optional

* EtherNet/IP™, Modbus® TCP, Webservice over Ethernet only available with Single-compartment housing

General data

Device description

The CoriolisMaster FCB400, FCH400 is the cost-effective and easy ABB mass flowmeter with a new modular transmitter.

The CoriolisMaster FCB400, FCH400 operates in accordance with the Coriolis principle. The design offers the following benefits:

- Space-saving, robust design.
- Variety of process connections.
- Modular, flexible output concept.

Transmitter with digital signal processor (DSP)

The transmitter for the CoriolisMaster FCB400, FCH400 incorporates a digital signal processor (DSP) that enables high-precision mass flow and density measurements to be taken. The Coriolis sensor signals are immediately converted into digital data without any intermediate analog steps.

Excellent long-term stability and reliability together with fast signal processing are achieved with the new DSP transmitter.

Self-diagnostic functions for the flowmeter sensor and the transmitter, in combination with absolute zero stability, are benefits you can count on to ensure accurate measurements are taken.

The CoriolisMaster FCB400, FCH400 transmitter is particularly well suited for use in the following cases:

- When mass flow needs to be measured to the highest degree of accuracy,
- When the density of the measuring medium is determined,
- When the components of a recipe are mixed together,
- When measuring non-conductive fluids or for example, highly viscous, solid-loaded liquids,
- in filling processes.

SIL-functional safety

Term	Value
DeviceType	CoriolisMaster FCB430, FCB450, FCH430, FCH450 with option 'CS'
Type of Assessment	Verification in accordance with IEC 61508 2, route 1S/1H
SIL capability	SIL2 (Low demand mode)
HFT	0
Component Type	B

Failure Rates	Design	
	Integral mount design	Remote mount design
SFF	93.3 %	93.2 %
PFD _{AVG} after 1 year (MTTR 48 hours)	6,91E-04	7,28E-04
PFD _{AVG} after 2 years (MTTR 48 hours)	1,31E-03	1,38E-03
PFD _{AVG} after 4 years (MTTR 48 hours)	2,54E-03	2,68E-03
λ_S	435 FIT	435 FIT
λ_{Dd}	1529 FIT	1616 FIT
λ_{Du}	142 FIT	149 FIT

SAFETY INSTRUCTIONS

The listed failure rates λ_S , λ_{Dd} , λ_{Du} and PFD_{AVG} relate to the failure rates of the Siemens norm SN29500 at an average component temperature of 40 °C (104 °F).

This corresponds to an average ambient temperature of 30 °C (86 °F).

Devices for legal metrology in accordance with MID / OIML R117

The Coriolis mass flowmeters CoriolisMaster FCBx50 / FCHx50 are type-tested for legal metrology in accordance with MID / OIML R117 in accuracy class 0.3. Additional information can be found on the corresponding certificate. The certificate is available in the download area at www.abb.com/flow.

Please the optional order code 'CM1' when ordering.

Please observe the additional remarks in the operating and commissioning instruction.

Note

Use in accordance with API / AGA standards is also possible.

... General data

FillMass batch function

Only for FCB450 / FCH450

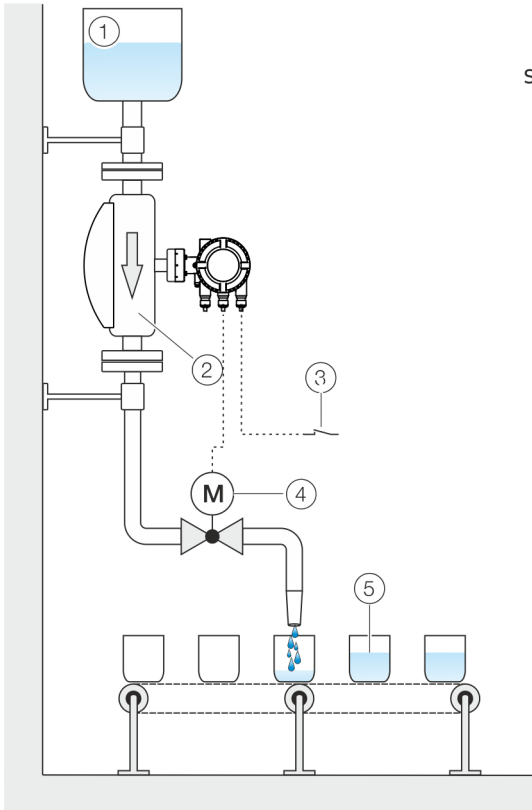

- ① Supply tank
- ② Sensor
- ③ Start / stop fill operation (digital input or field bus)
- ④ Fill valve
- ⑤ Filling tank

Figure 3: FillMass fill function

The integrated FillMass fill function allows filling processes with filling times of > 3 seconds. For this purpose, the filling quantity is given via an adjustable totalizer. The fill function is controlled via the HART interface or via the digital input.

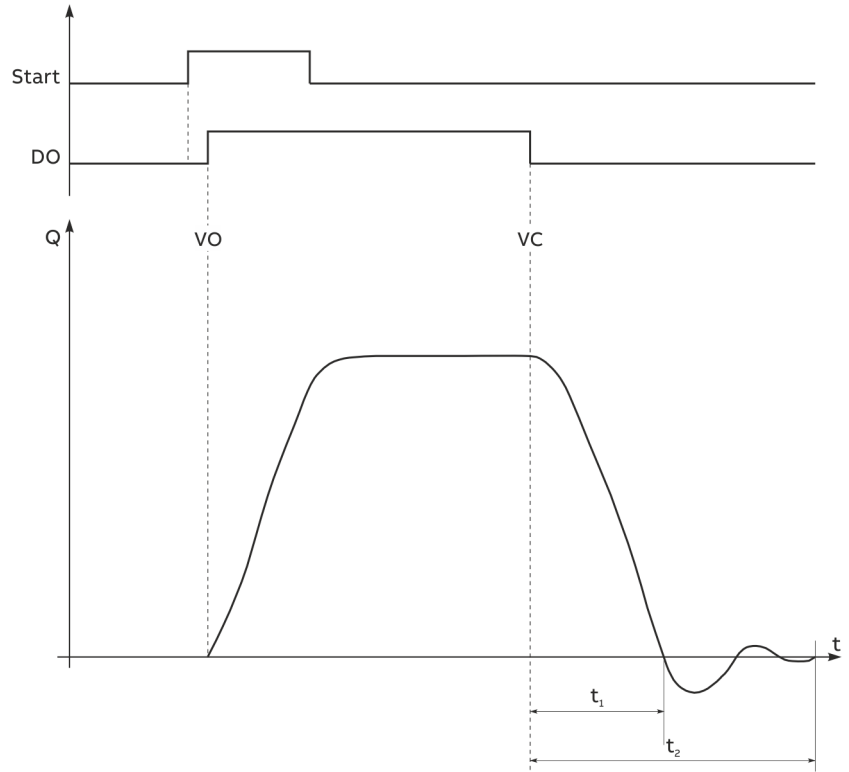

Start Start of the filling process via field bus or digital input

DO State of the digital output for the fill valve

Q Flow rate

VO Valve open (filling started)

VC Valve closed (fill quantity reached)

t_1 Valve closing time

t_2 Overrun time

The valve is triggered via one of the digital outputs and closed again once the preset filling quantity is reached. The transmitter measures the overrun quantity and calculates the overrun correction from this. Additionally, the low flow cut-off can be activated if required.

Concentration measurement DensiMass

Only for FCB450 / FCH450

The transmitter can calculate the current concentration from the measured density and temperature using concentration matrices.

The following concentration matrices are preconfigured in the transmitter as standard:

- Concentration of sodium hydroxide in water
- Concentration of alcohol in water
- Concentration of sugar in water
- Concentration of maize starch in water
- Concentration of wheat starch in water

In addition, the user can enter two user-defined matrices:

- Up to 100 values with one matrix
- Up to 50 values per matrix with two matrices

Calculating standard volumes and standard densities of liquids

If a suitable matrix is available, the DensiMass function also allows the measured volume to be corrected for any selected temperature.

The measured density can also be corrected for a given temperature.

However, this is only possible when measuring liquids and after entering an appropriate matrix.

This correction can also be performed using the default matrices (see above).

The calculated standard volumes and standard densities can also be issued for all other process variables.

The software 'DensiMatrix' is available for the easy input of the matrix.

Accuracy of the concentration measurement

The accuracy of the concentration measurement is determined in the first instance by the quality of the matrix data entered.

However, as the calculation is based on temperature and density (the input variables), the accuracy of the concentration measurement is ultimately determined by the measuring accuracy of the temperature and the density.

Example:

Density of 0 % alcohol in water at 20 °C (68 °F): 998.23 g/l

Density of 100 % alcohol in water at 20 °C (68 °F): 789.30 g/l

Concentration	Density
100 %	208.93 g/l
0.48 %	1 g/l
0.96 %	2 g/l
0.24 %	0.5 g/l

Thus, the accuracy class of the density measurement directly determines the accuracy of the concentration measurement.

... General data

Enhanced Coriolis Control (ECC)function

The Enhanced Coriolis Control (ECC)function has been specially developed for demanding applications, such as:

- Liquids with gas phase
- Liquids with rapidly changing densities
- Fill operations with surge phases at the beginning or end
- Liquids with high viscosity

After the ECC function is activated, the device applies a particularly quick control algorithm to control the oscillating tubes in the device and therefore provide significantly better behavior in the applications listed above.

In addition, the ECC function offers a special noise suppression filter for mass flow measurement and density measurement.

In the case of particularly demanding applications, disruptions can thus be actively filtered and the measurement can be implemented in a considerably more stable manner.

For the filters, a variety of time constants between 0.5 s and 8 s can be selected.

Since Coriolis mass flowmeters measure the mass flow and density separately, the CoriolisMaster features a separate filter each for mass flow measurement and density measurement.

Applications in accordance with API (American Petroleum Institute)

For applications in accordance with API Chapter 5.6, the CoriolisMaster FCB400, FCH400 provides special parameters:

- Calibration Pressure: Measuring medium pressure at which the device was calibrated at ABB.
- Calibration Temp.: Measuring medium temperature at which the device was calibrated at ABB.
- Pressure Level: Parameters for entry of the current operating pressure in the device by the user.
- Flow Compens. factor: Display / output of the current compensation factor for mass flow calculation.
- Density Comp. factor: Display / output of the current compensation factor for density calculation.
- P.Comp.Status (PECI): In accordance with API, the user can set the following states:
 - 1: CT: Compensation in the Coriolis flowmeter based on the current pressure entered in the 'Pressure Level' parameter.
 - 2: TD: Compensation in the Coriolis flowmeter switched off – compensation is performed externally (Tertiary Device)
 - 3: OS: Compensation in the Coriolis flowmeter switched off – compensation is not performed on site (Off Site)
 - 4: NA: Compensation in the Coriolis flowmeter switched off – compensation is not deemed to be necessary, since the device is operating at a pressure for which the device has been proved.

VeriMass erosion monitor

The integrated diagnosis function VeriMass allows the status of the meter tube to be monitored. This enables changes due to material erosion and the formation of deposits on the meter tube walls to be identified at an early stage.

If the set limit value is exceeded, an alarm is triggered, for example via the programmable digital output or HART, depending on the configuration.

The limit value for the erosion monitor can be set either automatically or manually.

Automatic adjustment

The transmitter monitors the sensor's driver current over a prolonged period and creates a 'fingerprint' for the relevant application. The transmitter generates a corresponding tolerance value for deviations in the driver current.

The transmitter compares the behavior of the driver current with the generated fingerprint and triggers the relevant error message in the event of prolonged deviations.

Manual adjustment

For applications where automatic adjustment of the erosion monitor does not provide a satisfactory result, the erosion monitor can be adjusted manually.

For more information, please contact ABB Service or the sales organization.

Flowmeter sensor

General installation conditions

Installation location and assembly

Note the following points when selecting the installation location and when mounting the sensor:

- The ambient conditions (IP rating, ambient temperature range T_{ambient}) of the device must be adhered to at the installation location.
- Sensors and transmitters must not be exposed to direct sunlight. If necessary, provide a suitable means of sun protection on site. The limit values for ambient temperature T_{ambient} must be adhered to.
- On flange devices, ensure that the counterflanges of the piping are aligned plane parallel. Only install flange devices with suitable gaskets.
- Prevent the sensor from coming into contact with other objects.
- The device is designed for industrial applications. No special EMC protective measures are required if the electromagnetic fields and interference at the installation location of the device comply with 'Best Practice' (in accordance with the standards listed in the declaration of conformity).
Maintain a suitable distance from electromagnetic fields and interference that extend beyond the usual dimensions.

Seals

Users are responsible for selecting and mounting suitable gaskets (material, shape).

Note the following points when selecting and mounting gaskets:

- Use gaskets made from a material that is compatible with the measuring medium and measuring medium temperature.
- Gaskets must not extend into the flow area, since possible turbulence may influence the accuracy of the device.

Calculating pressure loss

Pressure loss depends on the properties of the medium and the flow rate.

A good aid for pressure loss calculation is the Online ABB Product Selection Assistant (PSA) for flow at

www.abb.com/flow-selector.

... Flowmeter sensor

Brackets and supports

No special supports or damping are required for the device when the device is used and installed as intended. In systems designed in accordance with 'Best Practice', the forces acting on the device are already sufficiently absorbed. This is also true of devices installed in series or in parallel. For heavier devices, it is advisable to use additional supports / brackets on site. Doing this prevents damage to the process connections and piping from lateral forces. Please observe the following points:

- Mount two supports or brackets symmetrically in the immediate vicinity of the process connections.
- Do not fasten any supports or brackets to the housing of the flowmeter sensor.

Note

For increased vibration load, such as for example on ships, the use of the 'CL1' marine design is recommended.

Inlet section

The sensor does not require any inlet section. The devices can be installed directly before/after manifolds, valves or other equipment, provided that no cavitation is caused by this equipment.

Mounting position

The flowmeter operates in any mounting position. Depending on the measuring medium (liquid or gas) and the measuring medium temperature, certain mounting positions are preferable to others. For this purpose, consider the following examples. The preferred flow direction is indicated by the arrow on the sensor. The flow will be displayed as positive. The specified measuring accuracy can be achieved only in the calibrated flow direction (for forward flow calibration, this is only in the direction of the arrow; for the optional forward flow and reverse flow calibration, this can be in both flow directions).

Liquid measuring media

Observe the following points to avoid measuring errors:

- The meter tubes must always be completely filled with the measuring medium.
- The gases dissolved in the measuring medium must not leak out. To safeguard this, a minimum back pressure of 0.2 bar (2.9 psi) is recommended.
- The minimum vapor pressure of the measuring medium must be maintained when there is negative pressure in the meter tube or when liquids are gently simmering.
- During operation, there must be no phase transitions in the measuring medium.

Vertical installation

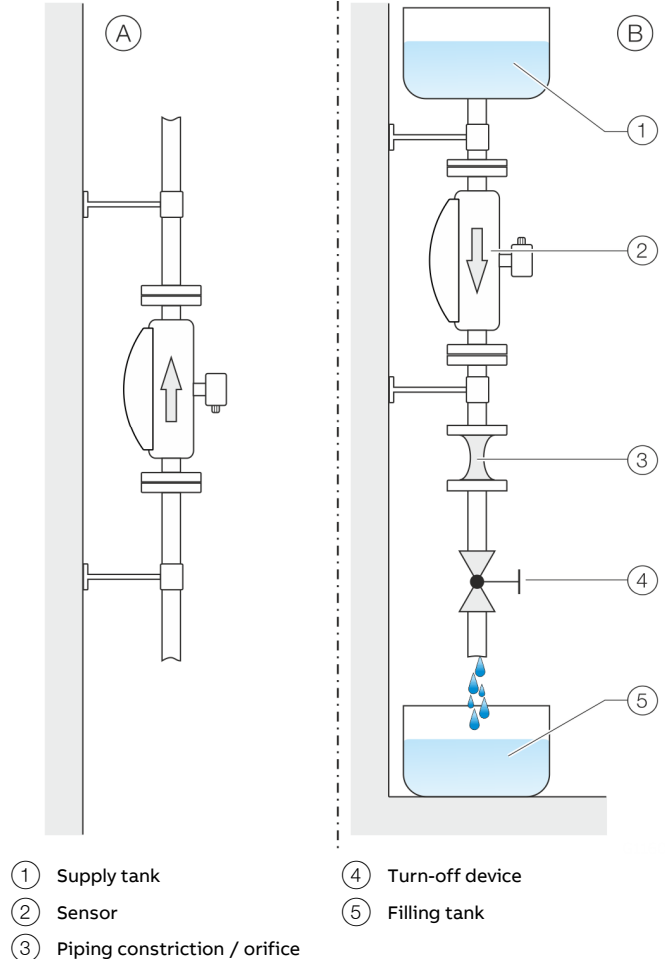

- ① Supply tank
- ② Sensor
- ③ Piping constriction / orifice
- ④ Turn-off device
- ⑤ Filling tank

Figure 4: Vertical installation

- (A) For vertical installation in a riser, no special measures are required.
- (B) For vertical installation in a downpipe, a piping constriction or an orifice must be installed below the sensor. Doing this prevents the sensor from draining during the measurement.

Horizontal installation

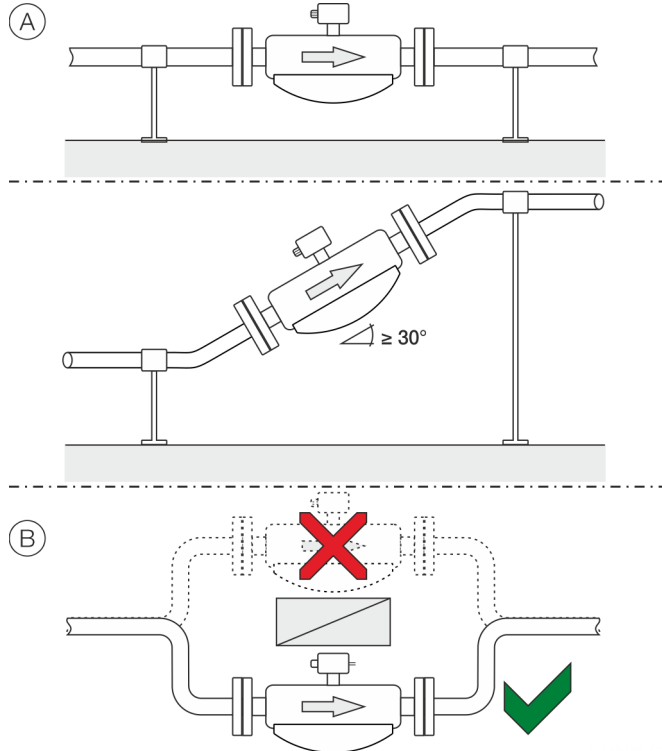

Figure 5: Horizontal installation

- (A) For liquid measuring media and horizontal installation, the transmitter and terminal box must point upward. If a self-draining installation is required, the sensor must be mounted at an incline of $\geq 30^\circ$.
- (B) Installing the sensor at the highest point of the piping leads to an increased number of measuring errors due to the accumulation of air or the formation of gas bubbles in the meter tube.

Gaseous measuring media

Observe the following points to avoid measuring errors:

- Gases must be dry and free of liquids and condensates.
- Avoid the accumulation of liquids and the formation of condensate in the meter tube.
- During operation, there must be no phase transitions in the measuring medium.

If there is a risk of condensate formation when using gaseous measuring media, note the following:

Ensure that condensates cannot accumulate in front of the sensor.

If this cannot be avoided, we recommend that the sensor is installed vertically with a downward flow direction.

Vertical installation

For vertical installation, no special measures are required.

Horizontal installation

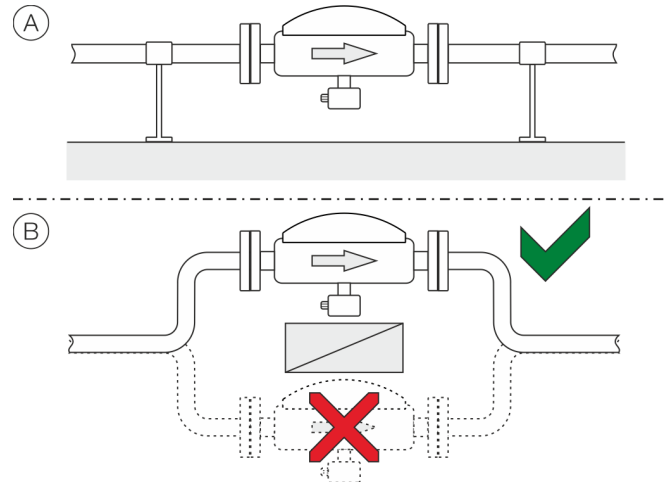
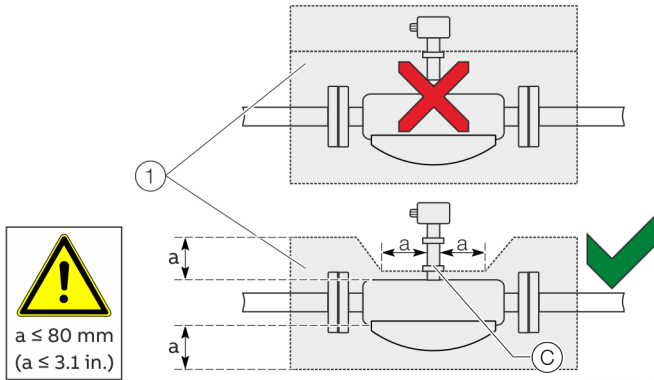

Figure 6: Horizontal installation

- (A) For gaseous measuring media and horizontal installation, the transmitter and terminal box must point downward.
- (B) Installing the sensor at the lowest point of the piping leads to an increased number of measuring errors due to the accumulation of liquid or the formation of condensates in the meter tube.

... Flowmeter sensor

Sensor insulation



① Insulation

Figure 7: Installation at $T_{\text{medium}} -50^{\circ}\text{ to }205^{\circ}\text{ C } (-58 \text{ to } 400^{\circ}\text{ F})$

The sensor may only be insulated in conjunction with the option TE1 'Extended tower length for sensor insulation' or TE2 'Extended tower length – insulation capacity with dual gasket,' as shown in Figure 7.

Heat tracing of the sensor

When operating the sensor in conjunction with heat tracing, the temperature at point ③ (Figure 7) $100^{\circ}\text{ C } (212^{\circ}\text{ F})$ may not be exceeded at any time!

Turn-off devices for the zero point adjustment

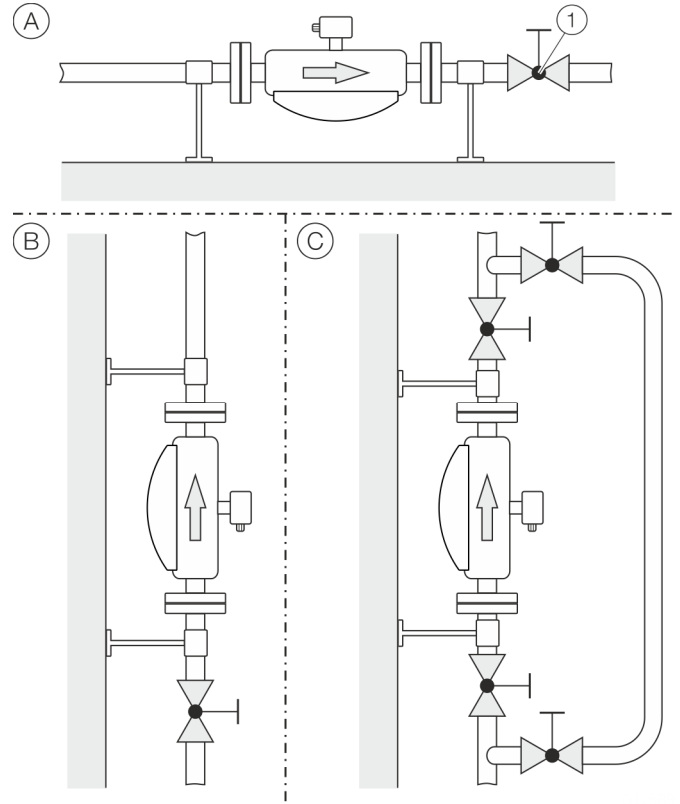

① Turn-off device

Figure 8: Mounting options for turn-off devices (example)

To guarantee the conditions for zero point balancing under operating conditions, turn-off devices are required in the piping:

- ① (A) At least on the outlet side when the transmitter is mounted in horizontal position
- ① (B) At least on the inlet side when the transmitter is mounted in vertical position.
- ① (C) In order to perform balancing during an ongoing process, it is advisable to mount a bypass pipe.

... Flowmeter sensor

Installation in EHEDG-compliant installations

- The required self-draining functionality of the sensor can only be guaranteed when the vertical mounting position or horizontal mounting position at a 30° incline is used. Refer to **Liquid measuring media** on page 10.
- The combination of process connections and gaskets selected by the operator may comprise only EHEDG-compliant components. Please note the information in the latest version of the EHEDG Position Paper: 'Hygienic Process connections to use with hygienic components and equipment' in this regard.
- The pipe fitting in accordance with DIN 11851 is approved for use in conjunction with an EHEDG-compliant gasket.

Devices for legal metrology in accordance with MID / OIML R117

The Coriolis mass flowmeters CoriolisMaster FCBx50 / FCHx50 are type-tested for legal metrology in accordance with MID / OIML R117 in accuracy class 0.3. Additional information can be found on the corresponding certificate. The certificate is available in the download area at www.abb.com/flow.

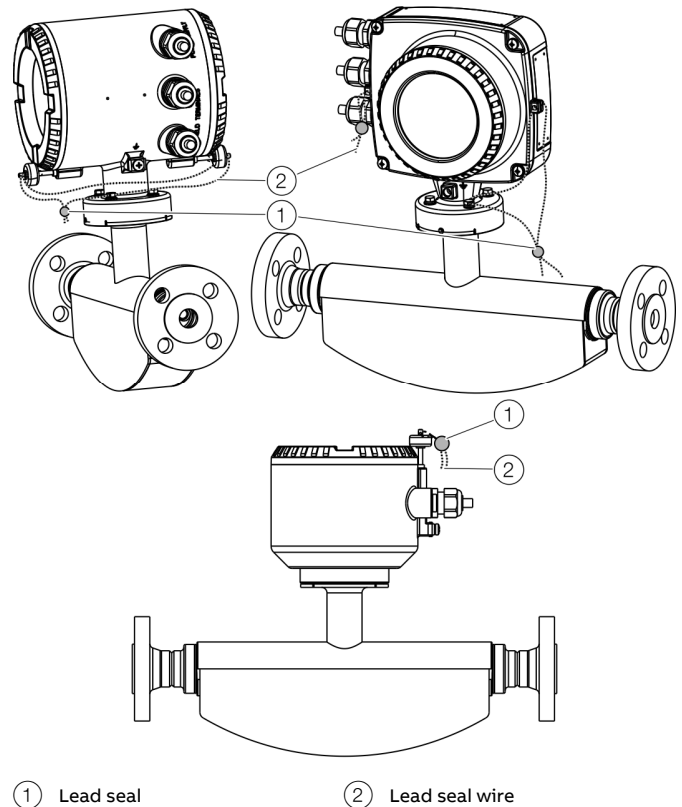

Figure 9: Sealing in accordance with MID / OIML R117 (example)

On devices for legal metrology in accordance with MID / OIML R117, the hardware write protection must be activated after commissioning.

This prevents a change in the parameterization of the devices.

To prevent deactivation of the hardware write protection or other manipulations during operation, the transmitter housing and the sensor housing connection box (with remote mount design) must be sealed.

For this purpose, a seal kit is available at ABB.

For the assembly of the seal, please observe the separate 'IN/FCX100/FCX400/MID/OIML-XA' instructions.

... Flowmeter sensor

Designs

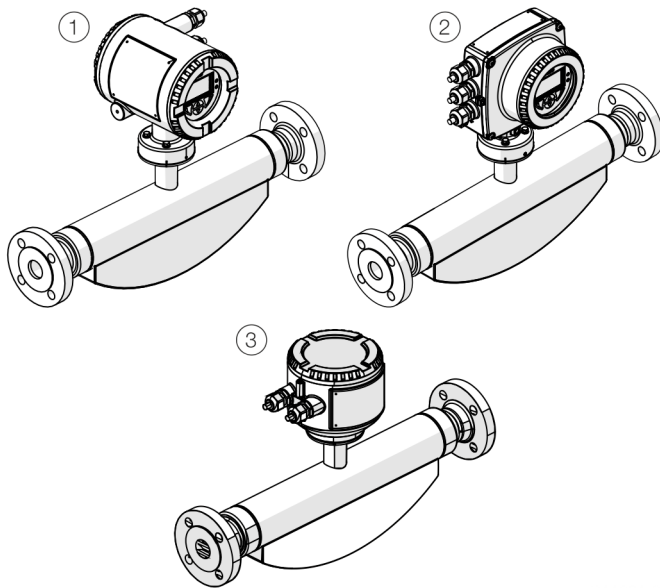

- ① Integral mount design with dual-compartment transmitter housing
- ② Integral mount design with single-compartment transmitter housing
- ③ Remote mount design (without transmitter)

Figure 10: Sensor FCB4xx / FCH4xx

Note

For additional information on dependencies and restrictions, and for help on product selection, please refer to the Online Product Selection Assistant (PSA) at www.abb.us/flow-selector.

Nominal diameter and measuring range

Nominal diameter	Q_{max} in kg/h (lb/h)
DN 15 (½ in)	0 to 8,000 (0 to 17,637)
DN 25 (1 in)	0 to 35,000 (0 to 77,162)
DN 50 (2 in)	0 to 90,000 (0 to 198,416)
DN 80 (3 in)	0 to 250,000 (0 to 551,156)
DN 100 (4 in)	0 to 520,000 (0 to 1,146,404)
DN 150 (6 in)	0 to 860,000 (0 to 1,895,975)

Recommended flow range

Fluids:

- The recommended flow range is 5 to 100 % of Q_{max} .
- Flow rates < 1 % of Q_{max} should be avoided.

Gases:

- The flow velocity of gases in the meter tube should not up-scale 0.3 mach [approx. 100 m/s (328 ft/s)].
- Increased deviation in repeatability should be expected from a flow velocity of approx. 80 m/s (262 ft/s).
- The maximum flow range of gases depends on the operating density. Appropriate dimensioning guidelines are available at www.abb.com/flow.

Measuring accuracy

Reference conditions

Calibration fluid	Water <ul style="list-style-type: none"> • Temperature: 25 °C (77 °F) ± 5 K • Pressure: 2 to 4 bar (29 to 58 psi)
Ambient temperature	25 °C (77 °F) +10 K / -5 K
Power supply	Line voltage in accordance with name plate $U_N \pm 1\%$
Warm-up phase	30 min
Installation	<ul style="list-style-type: none"> • Installation in accordance with Assembly Notes and Mounting positions • No visible gas phase • No external mechanical or hydraulic disturbances, particularly no cavitation
Output calibration	Pulse output

Measured error and repeatability

The measured error and repeatability are calculated as follows for the flow:

Scenario 1:

If

$$\text{Flow rate} \geq \frac{\text{Zero stability}}{(\text{base accuracy} / 100)}$$

Then:

- Maximum measured error: ± base accuracy as % of measured value.
- Repeatability: ± ½ × base accuracy as % of measured value.

Scenario 2:

If

$$\text{Flow rate} < \frac{\text{Zero stability}}{(\text{base accuracy} / 100)}$$

Then:

- Maximum measured error: ± (zero point stability / measured value) × 100 % of measured value
- Repeatability: ± ½ × (zero point stability / measured value) × 100% of measured value.

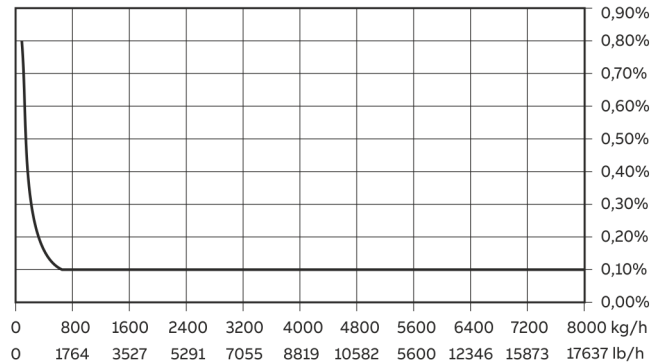

Figure 11: Measured error FCB450 DN 15 (Example)

FCx450			
Measurement	Flow rate	Measured error*	Repeatability*
dynamic			
100:1	80 kg/h (176.4 lb/h)	≤ 0.8 %	0.4 %
50:1	160 kg/h (352.7 lb/h)	≤ 0.4 %	0.2 %
10:1	800 kg/h (1763.7 lb/h)	≤ 0.1 %	0.05 %
2:1	4000 kg/h (8818.5 lb/h)	≤ 0.1 %	0.05 %
1:1	8000 kg/h (17,637 lb/h)	≤ 0.1 %	0.05 %

FCx450 – high accuracy			
Measurement	Flow rate	Measured error*	Repeatability*
dynamic			
100:1	80 kg/h (176.4 lb/h)	≤ 0.5 %	0.25 %
50:1	160 kg/h (352.7 lb/h)	≤ 0.25 %	0.122 %
10:1	800 kg/h (1763.7 lb/h)	≤ 0.1 %	0.05 %
2:1	4000 kg/h (8818.5 lb/h)	≤ 0.1 %	0.05 %
1:1	8000 kg/h (17,637 lb/h)	≤ 0.1 %	0.05 %

* Enter measured error and repeatability as % of measured value

... Flowmeter sensor

Measured error and base accuracy for liquids

	FCx430	FCx450	FCx450 – high accuracy
Order code flow calibration	A, B, E, J, K, N	C, D, L, M	D, M
Order code density calibration	1	3, 4	5
Mass flow*	±0.4 % ±0.25 % ±0.2 %	±0.15 % ±0.1 %	±0.1 %
Volume flow*	±0.4 % ±0.25 % ±0.2 %	±0.15 %	±0.11 %
Density	0.010 kg/l**	0.002 kg/l** 0.001 kg/l**	0.0005 kg/l**
Repeatability for flow rate	Refer to Measured error and repeatability on page 15.		
Repeatability for density	0.002 kg/l**	0.002 kg/l** 0.001 kg/l**	0.00025 kg/l**
Temperature	1 K	0.5 K	0.2 K

Measured error and base accuracy for gases

	FCx430	FCx450	FCx450 – high accuracy
Order code flow calibration	A, B, E, J, K, N	C, D, L, M	D, M
Order code density calibration	1	3, 4	5
Mass flow*	±1 %	±0.5 %	±0.5 %
Temperature	1 K	0.5 K	0.2 K

* Enter measured error and base accuracy as % of measured value

** For the density range from 0.5 to 1.8 kg/dm³

Zero point stability

Nominal diameter	FCx430	FCx450	FCx450 – high accuracy
Order code flow calibration	A, B, E, J, K, N	C, D, L, M	D, M
Order code density calibration	1	3, 4	5
DN 15 (½ in.)	0.64 kg/h (1.41 lb/h)	0.4 kg/h (0.88 lb/h)	
DN 25 (1 in.)	2.16 kg/h (4.76 lb/h)	1.35 kg/h (2.98 lb/h)	
DN 50 (2 in.)	7.20 kg/h (15.87 lb/h)	4.5 kg/h (9.92 lb/h)	
DN 80 (3 in.)	20 kg/h (44 lb/h)	20 kg/h (44 lb/h)	
DN 100 (4 in.)	41.6 kg/h (91.7 lb/h)	41.6 kg/h (91.7 lb/h)	
DN 150 (6 in.)	68.8 kg/h (151.68 lb/h)	68.8 kg/h (151.68 lb/h)	

Effect of the medium temperature

	FCx430	FCx450	FCx450 – high accuracy
Order code flow calibration	A, B, E, J, K, N	C, D, L, M	D, M
Order code density calibration	1	3, 4	5
On flow rate	< ±0.0015 % of Q _{max} / 1 K (1.8 °F)	< ±0.0015 % of Q _{max} / 1 K (1.8 °F)	< ±0.0004 % of Q _{max} / 1 K (1.8 °F)
On density	< 0.0001 kg/dm ³ per 1 K (1.8 °F)		< 0.0001 kg/dm ³ per 1 K (1.8 °F)

Effect of the operating pressure

Nominal diameter	Flow*	Density [kg/dm ³ / bar]
DN 15 (½ in.)	-0.002 %	No effect
DN 25 (1 in.)	-0.013 %	0.00035
DN 50 (2 in.)	-0.010 %	0.00027
DN 80 (3 in.)	-0.006 %	0.00019
DN 100 (4 in.)	-0.009 %	0.00024
DN 150 (6 in.)	-0.035 %	0.00045

* Influence of operating pressure as % of measured value per bar (1 bar = 14.5 psi)

Specifications

Pressure loss

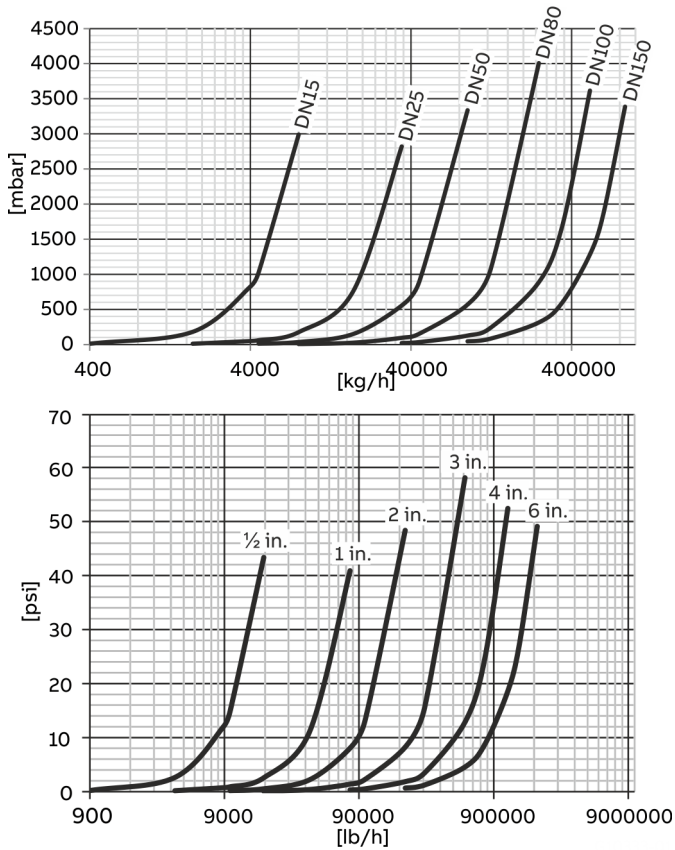

Figure 12: Pressure loss curve (measured with water, viscosity: 1 mPas)

Viscosity range

For dynamic viscosities ≥ 1 Pas (1000 mPas = 1000 cP), please consult ABB.

Temperature limits °C (°F)

Note

When using the device in potentially explosive atmospheres, note the additional temperature data in **Temperature data** on page 90!

Measuring medium temperature T_{medium}

- FCx430: -50 to 160 °C (-58 to 320 °F)
- FCx450: -50 to 205 °C (-58 to 401 °F)

In devices with order code 'Extended tower length – TE3', the measuring medium temperature must be limited to a maximum of 140 °C (284 °F) from an ambient temperature of ≥ 65 °C (149 °F).

Ambient temperature T_{amb} .

- Standard: -20 to 70 °C (-4 to 158 °F)
- Optional: -40 to 70 °C (-40 to 158 °F)

Process connections

For an overview of available process connection versions, see **Overview – models** on page 3.

Pressure ratings

The maximum permissible operating pressure is determined by the respective process connection, the temperature of the medium to be measured, the screws, and the gasket material. For an overview of available pressure ratings, see **Overview – models** on page 3.

Housing as a protective device (optional)

Order code PR5

Maximum burst pressure 60 bar (870 psi)

Optional order code PR6 and PR7 on request

- Increased burst pressures up to 100 bar (1450 psi), possible for nominal diameters DN 15 to 100 ($\frac{1}{2}$ to 4 in.).
- Increased burst pressures up to 150 bar (2175 psi), possible for nominal diameters DN 15 to 80 ($\frac{1}{2}$ to 3 in.).
- Purge connections are available on request.

Pressure Equipment Directive

Conformity assessment in accordance with Category III, fluid group 1, gas

Note the corrosion resistance of the meter tube materials in relation to the measuring medium.

CRN approval

Certain device versions and connection options have CRN approval under number 'CRN 0F15656.5'.

Please contact ABB for more information.

... Flowmeter sensor

Installation lengths in accordance with NAMUR standards

The CoriolisMaster FCB400, FCH400 is the ideal device for use in accordance with NAMUR standards.

While also conforming to other standards, the device can be ordered with installation lengths in accordance with NAMUR standards.

The exact lengths can be found in the tables in **Devices DN 15 to 150 in NAMUR standard installation lengths (order option S5, S7)** on page 32 (for integral mount design) and **Devices DN 15 to 150 in NAMUR standard installation lengths (order option S5, S7)** on page 47 (for remote mount design).

Meter tube inside diameter

Inside diameter of the meter tube of the Coriolis mass flowmeter CoriolisMaster FCB400, FCH400.

Nominal diameter	Meter tube inside diameter
DN 15 (½ in)	2 × 8 mm (2 × 0.31 in)
DN 25 (1 in)	2 × 16 mm (2 × 0.63 in)
DN 50 (2 in)	2 × 23.7 mm (2 × 0.93 in)
DN 80 (3 in)	2 × 36.62 mm (2 × 1.44 in)
DN 100 (4 in)	2 × 52.51 mm (2 × 2.07 in)
DN 150 (6 in)	2 × 68.9 mm (2 × 2.71 in)

IP rating

In accordance with EN60529: IP 65 / IP 67, NEMA 4X

Note

The sensor in remote mount design is approved for an immersion depth up to 5 m (16.4 ft) in accordance with IP rating IP 68.

Materials for the transmitter terminal box

Integral mount design

Material	Cast aluminum or stainless steel 1.4409 (ASTM CF3M)
Paint	Paint coat ≥ 80 µm thick, RAL 9002 (light gray)
Cable gland**	Polyamide or stainless steel*

Remote mount design

Material	Cast aluminum
Paint	Mid-section: Paint coat ≥ 80 µm thick, RAL 7012 (basalt gray) Front cover / rear cover: RAL 9002 (light gray)
Cable gland**	Polyamide

* In the case of explosion-proof design for -40 °C (-40 °F) ambient temperature)

** Cable gland with M20 x 1.5 or NPT thread, to be selected via the order number.

Materials for the sensor

Wetted components

FCB400	FCH400
Stainless steel 1.4435 or 1.4404 (AISI 316L)	Stainless steel 1.4435 or 1.4404 (AISI 316L)
C4* nickel alloy (2.4610) or C22 nickel alloy (2.4602) –	
Optional: Manufacture in accordance with NACE MR0175 and MR0103 (ISO 15156)	

Sensor housing**

Stainless steel 1.4404 (AISI 316L), 1.4301 (AISI 304), 1.4308 (ASTM CF8)

* Hastelloy C is a registered trademark of Haynes International. C4 and C22 nickel alloys are equivalent to Hastelloy C4 and Hastelloy C22.

** If the wetted parts of the sensor are made from nickel alloy then parts of the sensor housing (splitter) are also manufactured from nickel alloy. However, the prevailing parts remain manufactured from the specified material.

Roughness for flanges in accordance with EN 1092-1, ASME and JIS

	EN 1092-1 B1	EN 1092-1 B2	
Pressure rating	≤ PN 40	≥ PN 63	
Mean roughness value Ra	3.2 to 12.5 µm	0.8 to 3.2 µm	
Roughness depth Rz	12.5 to 50.0 µm	3.2 to 12.5 µm	
	ASME B 16.5	JIS B 2220	JIS 10K
Mean roughness value Ra	0.8 to 3.2 µm	3.2 to 6.3 µm	3.2 to 6.3 µm
Roughness depth Rz	3.2 to 12.5 µm	12.5 to 25 µm	12.5 to 25 µm

Material load for process connections

Note

You can reference the availability of the different process connections in the Online ABB Product Selection Assistant (PSA) for flow www.abb.com/flow-selector.

- Not all connections shown here are available in all the devices and designs.
- The permissible material load of the device can additionally differ from the material load of the connection. The permissible limit values (pressure rating / measuring medium temperature T_{medium}) can be found on the name plate.

Design	Nominal diameter	PS _{max}	TS _{max}	TS _{min}
Pipe fitting (DIN 11851)	DN 15 to DN 40 (½ to 1½ in)	40 bar (290 psi) (580 psi)	140 °C (284 °F)	-40 °C (-40 °F)
	DN 50 to DN 100 (2 to 4 in)	25 bar (290 psi) (363 psi)	140 °C (284 °F)	-40 °C (-40 °F)
Pipe fitting (SMS 1145)	DN 25 to DN 80 (1 to 3 in)	6 bar (290 psi) (87 psi)	140 °C (284 °F)	-40 °C (-40 °F)
Tri-Clamp (DIN 32676)	DN 15 to DN 50 (½ to 2 in)	16 bar (290 psi) (232 psi)	120 °C (248 °F)	-40 °C (-40 °F)
	DN 65 to DN 100 (2½ to 4 in)	10 bar (290 psi) (145 psi)	120 °C (248 °F)	-40 °C (-40 °F)
ASME BPE Clamp	< DN 80 (< 3 in)	17.1 bar (290 psi) (248 psi)	121 °C (249.8 °F)	-40 °C (-40 °F)
	DN 80 (< 3 in)	15.5 bar (290 psi) (224.8 psi)	121 °C (249.8 °F)	-40 °C (-40 °F)
	DN 100 (< 4 in)	12.9 bar (290 psi) (187.1 psi)	121 °C (249.8 °F)	-40 °C (-40 °F)

Material load curves for flange devices

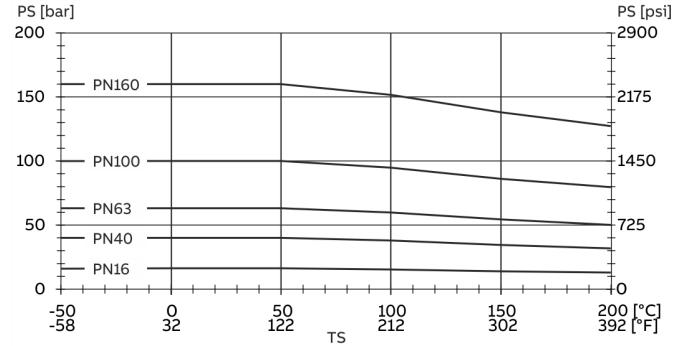

Figure 13: Stainless steel DIN flange 1.4571 / 1.4404 (316Ti / 316L) to DN 200 (8 in)

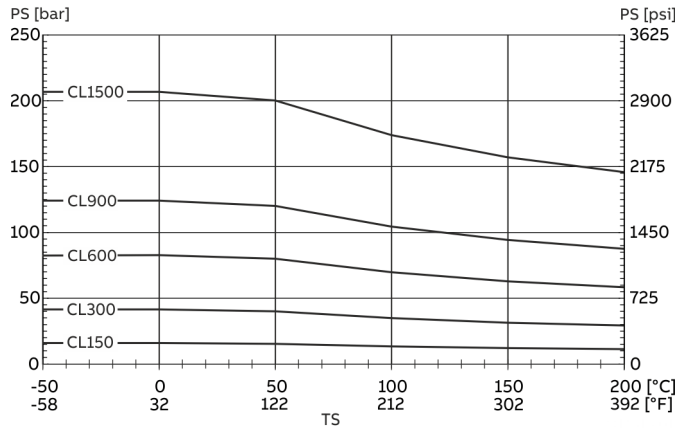

Figure 14: Stainless steel ASME flange 1.4571 / 1.4404 (316Ti / 316L) up to DN 200 (8 in.)

... Flowmeter sensor

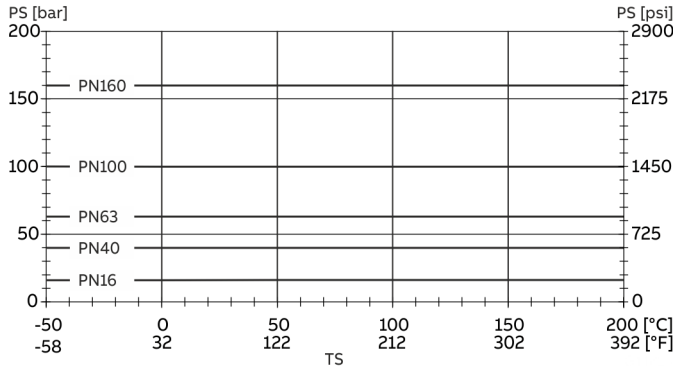

Figure 15: Nickel alloy DIN flange C4 (2.4610) or nickel alloy C22 (2.4602) up to DN 200 (8 in.)

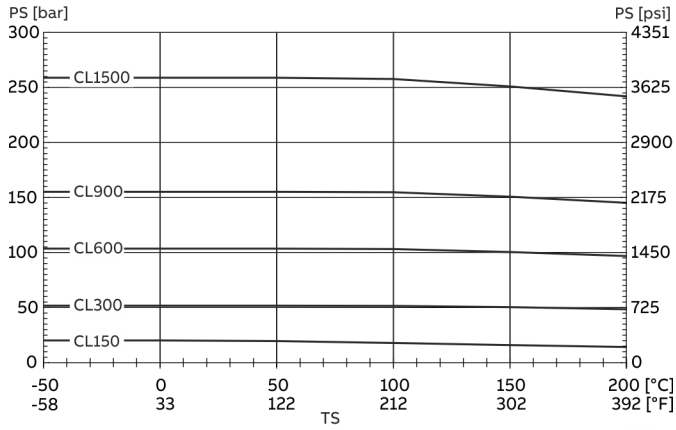

Figure 16: Nickel alloy ASME flange C4 (2.4610) or nickel alloy C22 (2.4602) up to DN 200 (in.)

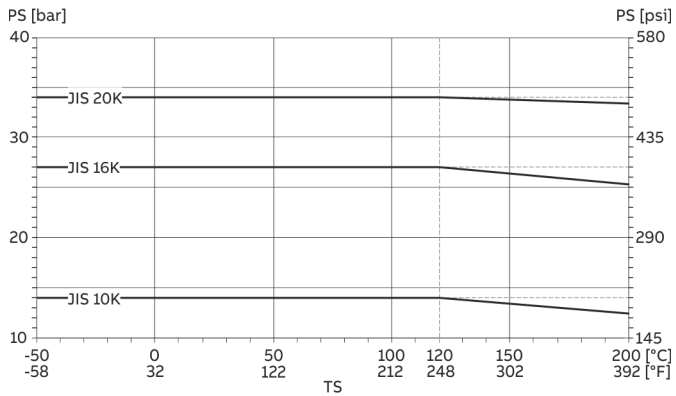

Figure 17: Stainless steel JIS B2220 flange 1.4435 or 1.4404 (AISI 316L), nickel alloy C4 (2.4610) or nickel alloy C22 (2.4602)

Dimensions for devices with integral mount design

Devices with single-compartment transmitter housing

In integral mount design devices, the height (E / E1) and the dimensions provided in Figure 18 differ from the dimensions of the devices with dual-compartment transmitter housings.

- To the height (E / E1), 13 mm (0.51 in.) must be added.
- All other dimensions and the weight are unchanged.

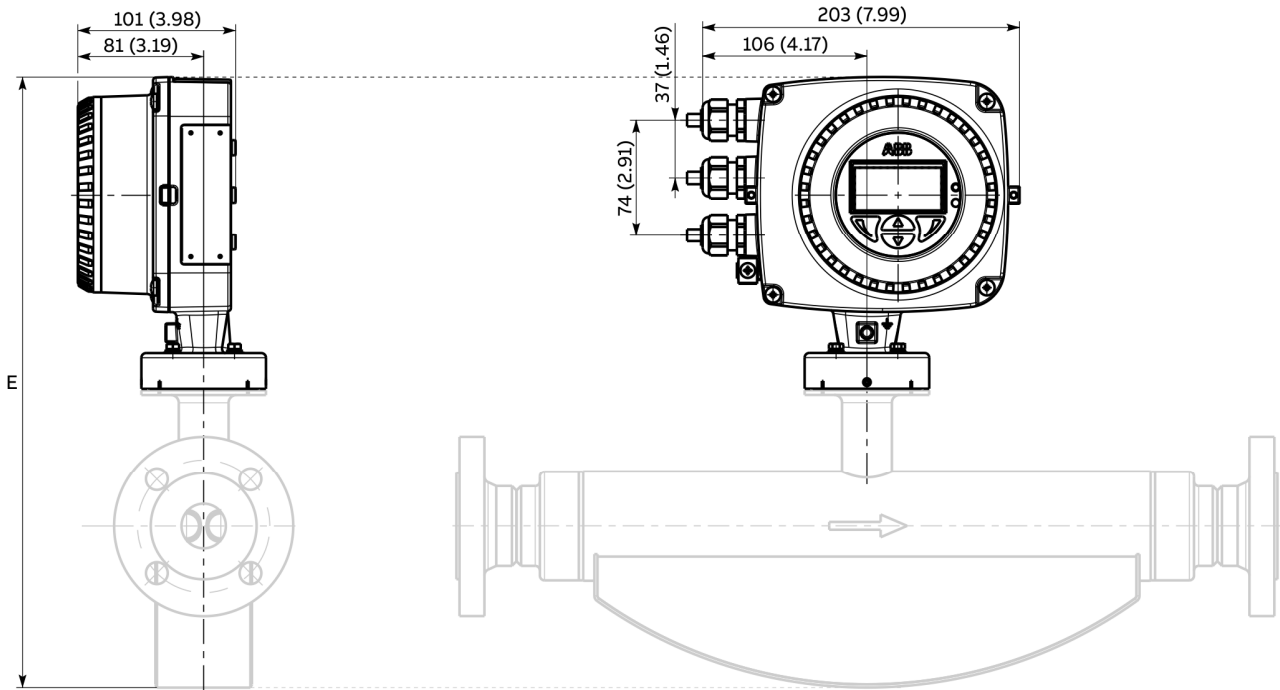

Figure 18: Integral mount design with single-compartment transmitter housing

... Flowmeter sensor

Devices with meter tube nominal diameter DN 15 to 50 and flange DN 10 to 65

Sensor with wetted parts made from stainless steel.

All dimensions and weights are specified in mm (in) or kg (lb).

Standard Version

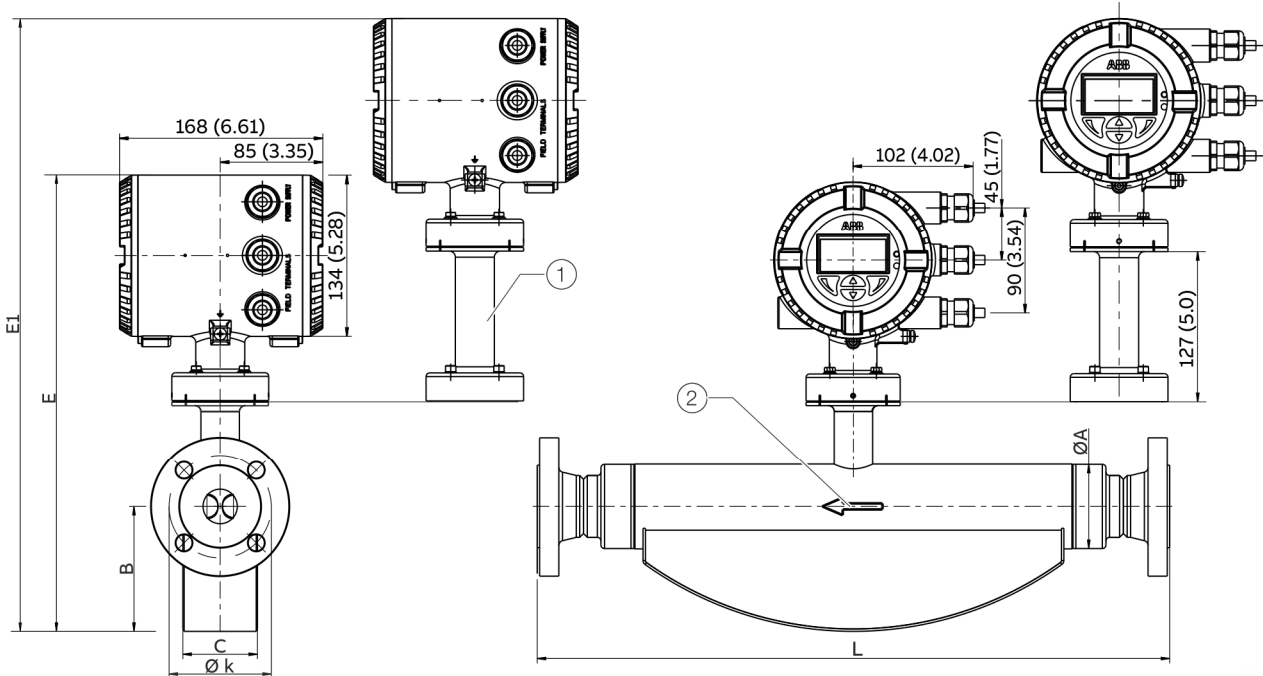

Marine version – CL1

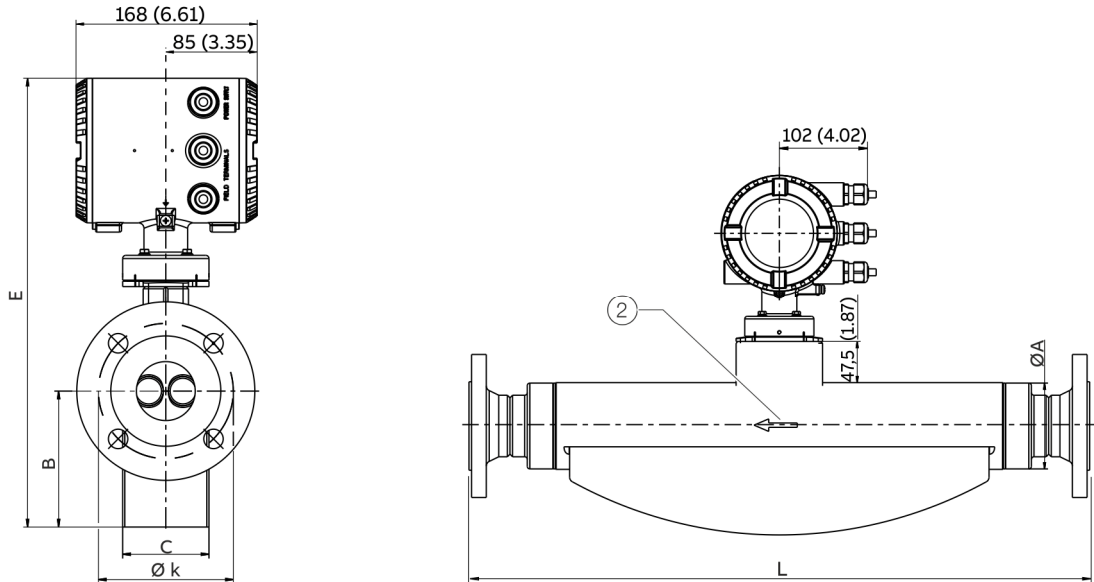

- ① 'Extended tower length – TE1, TE2' option or 'Pressure rating of sensor secondary housing – PR5, PR6, PR7' option
- ② Flow direction

Figure 1: Integral mount design with dual-compartment transmitter housing

Meter tube nominal diameter DN 15 (½ in)									
DN / process connection		L	Ø k	Ø A	B	C	E	E1*	Weight max.
10 (¾)	PN 40 (EN 1092-1 B1)	385 (15.2)	60 (2.4)	44.5 (1.8)	80 (3.2)	49 (1.9)	345 (13.58)	472 (18.58)	13 (28.7)
	JIS 10K	385 (15.2)	65 (2.6)						
	JIS 16K	385 (15.2)	65 (2.6)						
	JIS 20K	385 (15.2)	65 (2.6)						
15 (½)	PN 40 (EN 1092-1 B1)	385 (15.2)	65 (2.6)						
	PN 63 (EN 1092-1 B2)	403 (15.9)	75 (3.0)						
	PN 100 (EN 1092-1 B2)								
	CL150 (ASME B16.5)	435 (17.13)	60.5 (2.4)						
	CL300 (ASME B16.5)	421 (16.6)	66.5 (2.6)						
	CL600 (ASME B16.5)								
	CL900 (ASME B16.5)		82.6 (3.3)						
	CL1500 (ASME B16.5)								
	JIS 10K	385 (15.2)	70 (2.8)						
	JIS 16K	385 (15.2)	70 (2.8)						
	JIS 20K	385 (15.2)	70 (2.8)						
20 (¾)	PN 40 (EN 1092-1 B1)	421 (16.6)	75 (3.0)						
	CL150 (ASME B16.5)	421 (16.6)	69.9 (2.8)						
	JIS 10K	421 (16.6)	75 (3.0)						
	JIS 16K	385 (15.2)	75 (3.0)						
	JIS 20K	385 (15.2)	75 (3.0)						

* Standard version: devices with 'Extended tower length – TE1, TE2' or 'pressure rating of sensor secondary housing'.

Tolerance for dimension L: +0 / -3 mm (+0 / -0.018 in)

... Flowmeter sensor

Meter tube nominal diameter DN 25 (1 in)									
DN / process connection		L	Ø k	Ø A	B	C	E	E1*	Weight max.
20 (¾)	PN 40 (EN 1092-1 B1)	576 (22.7)	75 (3.0)	69.5 (2.74)	103 (4.06)	62 (2.44)	386 (15.2)	513 (20.20)	15 (33.1)
	CL150 (ASME B16.5)	575 (22.6)	69.9 (2.8)						
	JIS 10K	576 (22.7)	75 (3.0)						
	JIS 16K	576 (22.7)	75 (3.0)						
	JIS 20K	576 (22.7)	75 (3.0)						
25 (1)	PN 40 (EN 1092-1 B1)	525 (20.7)	85 (3.3)						
	PN 63 (EN 1092-1 B2)	564 (22.2)	100 (3.9)						
	PN 100 (EN 1092-1 B2)								
	CL150 (ASME B16.5)	575 (22.6)	79.2 (3.1)						
	CL300 (ASME B16.5)	576 (22.7)	88.9 (3.5)						
	CL600 (ASME B16.5)								
	CL900 (ASME B16.5)	576 (22.7)	101.6 (4.0)						
	CL1500 (ASME B16.5)								
	JIS 10K	525 (20.7)	90 (3.54)						
	JIS 16K	525 (20.7)	90 (3.54)						
JIS 20K	525 (20.7)	90 (3.54)							
40 (1½)	PN 40 (EN 1092-1 B1)	576 (22.7)	110 (4.33)						
	PN 63 (EN 1092-1 B2)	572 (22.5)	125 (4.92)						
	PN 100 (EN 1092-1 B2)								
	CL150 (ASME B16.5)	576 (22.7)	98.6 (3.88)						
	CL300 (ASME B16.5)	576 (22.7)	114.3 (45.0)						
	CL600 (ASME B16.5)								
	JIS 10K	576 (22.7)	105 (4.13)						
	JIS 16K	576 (22.7)	105 (4.13)						
JIS 20K	576 (22.7)	105 (4.13)							

* Standard version: devices with 'Extended tower length – TE1, TE2' or 'pressure rating of sensor secondary housing'.

Tolerance for dimension L: +0 / -3 mm (+0 / -0.018 in)

Meter tube nominal diameter DN 50 (2 in)									
DN / process connection		L	Ø k	Ø A	B	C	E	E1*	Weight max.
40 (1½)	PN 40 (EN 1092-1 B1)	763 (30)	110 (4.33)	99 (3.9)	126 (4.96)	80 (3.15)	416 (16.38)	543 (21.38)	31 (68.3)
	PN 63 (EN 1092-1 B2)	745 (29.33)	125 (4.92)						
	PN 100 (EN 1092-1 B2)								
	CL150 (ASME B16.5)	763 (30)	98.6 (3.88)						
	CL300 (ASME B16.5)	756 (29.76)	114.3 (4.5)						
	CL600 (ASME B16.5)								
	CL900 (ASME B16.5)	780 (30.71)	124 (4.88)						
	CL1500 (ASME B16.5)								
	JIS 10K	763 (30)	105 (4.13)						
	JIS 16K	763 (30)	105 (4.13)						
JIS 20K	763 (30)	105 (4.13)							
50 (2)	PN 40 (EN 1092-1 B1)	715 (28.15)	125 (4.92)						
	PN 63 (EN 1092-1 B2)	745 (29.33)	135 (5.31)						
	PN 100 (EN 1092-1 B2)	757 (29.80)	145 (5.71)						
	CL150 (ASME B16.5)	715 (28.15)	120.7 (4.75)						
	CL300 (ASME B16.5)	763 (30)	127 (5.0)						
	CL600 (ASME B16.5)	773 (30.43)	127 (5.0)						
	CL900 (ASME B16.5)	790 (31.1)	165.1 (6.5)						
	CL1500 (ASME B16.5)								
	JIS 10K	715 (28.15)	120 (4.72)						
	JIS 16K	715 (28.15)	120 (4.72)						
JIS 20K	715 (28.15)	120 (4.72)							
65 (2½)	PN 40 (EN 1092-1 B1)	763 (30)	145 (5.71)						
	CL150 (ASME B16.5)	763 (30)	139.7 (5.5)						
	CL900 (ASME B16.5)	800 (31.5)	190.5 (7.5)						
	CL1500 (ASME B16.5)								
	JIS 10K	763 (30)	140 (5.51)						
	JIS 16K	763 (30)	140 (5.51)						
JIS 20K	763 (30)	140 (5.51)							

* Standard version: devices with 'Extended tower length – TE1, TE2' or 'pressure rating of sensor secondary housing'.

Tolerance for dimension L: +0 / -3 mm (+0 / -0.018 in)

... Flowmeter sensor

Devices with meter tube nominal diameter DN 80 and flange DN 65 to 100

Sensor with wetted parts made from stainless steel.

All dimensions and weights are specified in mm (in) or kg (lb).

Standard Version

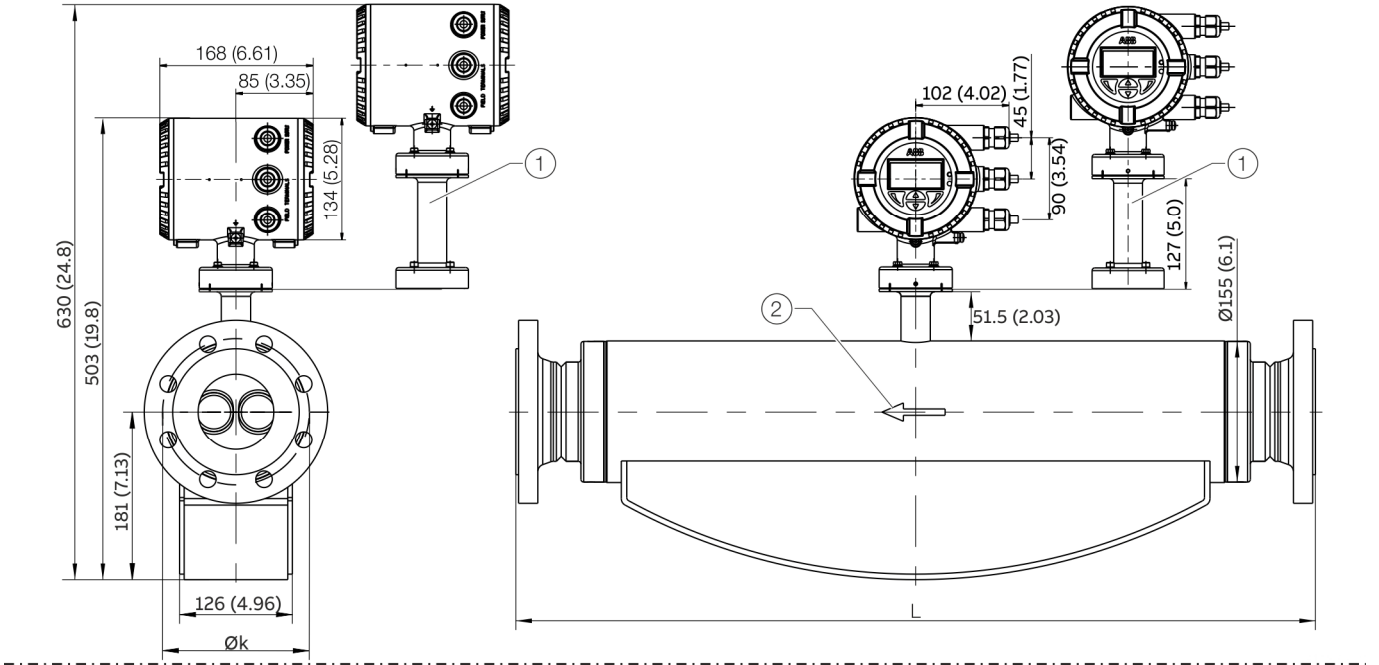

Marine version – CL1

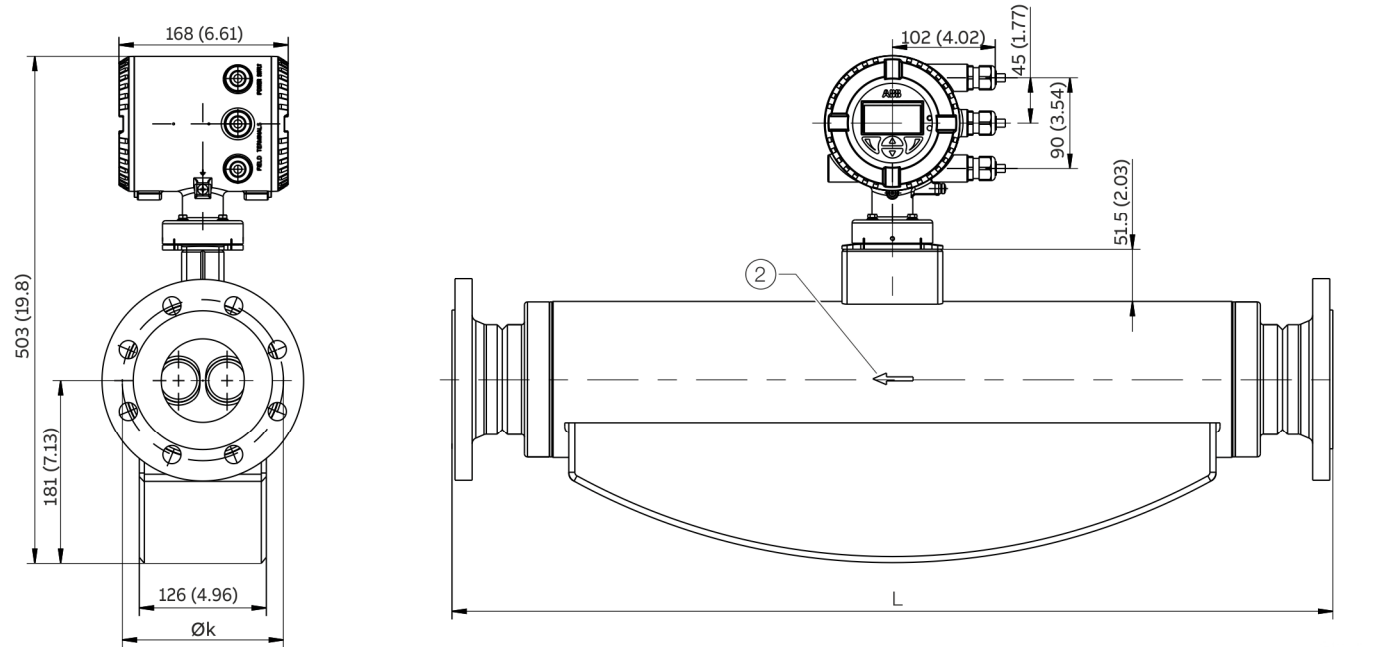

① 'Extended tower length – TE1, TE2' option or 'Pressure rating of sensor secondary housing – PR5, PR6, PR7' option

② Flow direction

Figure 2: Integral mount design with dual-compartment transmitter housing

Meter tube nominal diameter DN 80 (3 in)				
DN / process connection	L	Ø k	Weight max.	
65 (2½ in)	PN 16 (EN 1092-1 B1)	—*	—*	
	PN 40 (EN 1092-1 B1)	910 (35.83)	145 (5.71)	74 (163.1)
	PN 63 (EN 1092-1 B2)		160 (6.30)	78 (172.0)
	PN 100 (EN 1092-1 B2)		170 (6.69)	82 (180.8)
	CL150 (ASME B16.5)	—*	—*	—*
	CL300 (ASME B16.5)	920 (36.22)	149.4 (5.88)	76 (167.6)
	CL600 (ASME B16.5)			77 (169.8)
	CL900 (ASME B16.5)	965 (37.99)	190.5 (7.50)	94 (207.23)
	CL1500 (ASME B16.5)			
	JIS 10K	910 (35.83)	140 (5.5)	74 (163.1)
	JIS 16K	910 (35,83)	140 (5,5)	74 (163.1)
	JIS 20K	920 (36.22)	140 (5.5)	74 (163.1)
80 (3 in)	PN 16 (EN 1092-1 B1)	870 (34.25)	160 (6.30)	74 (163.1)
	PN 40 (EN 1092-1 B1)			75 (165.4)
	PN 63 (EN 1092-1 B2)	910 (35.83)	170 (6.69)	79 (174.2)
	PN 100 (EN 1092-1 B2)		180 (7.09)	85 (187.4)
	CL150 (ASME B16.5)	880 (34.65)	152.4 (6.00)	75 (165.4)
	CL300 (ASME B16.5)	895 (35.24)	168.1 (6.62)	79 (174.2)
	CL600 (ASME B16.5)	920 (36.22)		82 (180.8)
	CL900 (ASME B16.5)	1100 (43.31)	190.5 (7.50)	94 (207.23)
	CL1500 (ASME B16.5)	1300 (51.18)	203.2 (8.00)	106 (233.7)
	JIS 10K	870 (34.25)	150 (5.91)	75 (165.4)
	JIS 16K	870 (34.25)	150 (5.91)	75 (165.4)
	JIS 20K	910 (35.83)	150 (5.91)	75 (165.4)
100 (4 in)	PN 16 (EN 1092-1 B1)	875 (34.45)	180 (7.09)	75 (165.3)
	PN 40 (EN 1092-1 B1)		190 (7.48)	77 (170)
	PN 63 (EN 1092-1 B2)	1060 (41.73)	200 (7.87)	86 (189.6)
	PN 100 (EN 1092-1 B2)	1080 (42.52)	210 (8.27)	94 (207.23)
	CL150 (ASME B16.5)	880 (34.65)	190.5 (7.50)	77 (169.8)
	CL300 (ASME B16.5)	1075 (42.32)	200.2 (7.88)	91 (200.6)
	CL600 (ASME B16.5)	1100 (43.31)	215.9 (8.50)	101 (222.7)
	CL900 (ASME B16.5)	1130 (44.49)	234.9 (9.25)	111 (244.7)
	CL1500 (ASME B16.5)	1150 (45.28)	241.3 (9.50)	126 (277.8)
	JIS 10K	1060 (41.73)	175 (6.86)	85 (187.4)
	JIS 16K	1060 (41.73)	175 (6.86)	85 (187.4)
	JIS 20K	1060 (41.73)	175 (6.86)	85 (187.4)

* On request

Tolerance for dimension L: +0 / -3 mm (+0 / -0.018 in)

... Flowmeter sensor

Devices with meter tube nominal diameter DN 100 and flange DN 80 to 150

Sensor with wetted parts made from stainless steel.

All dimensions and weights are specified in mm (in) or kg (lb).

Standard Version

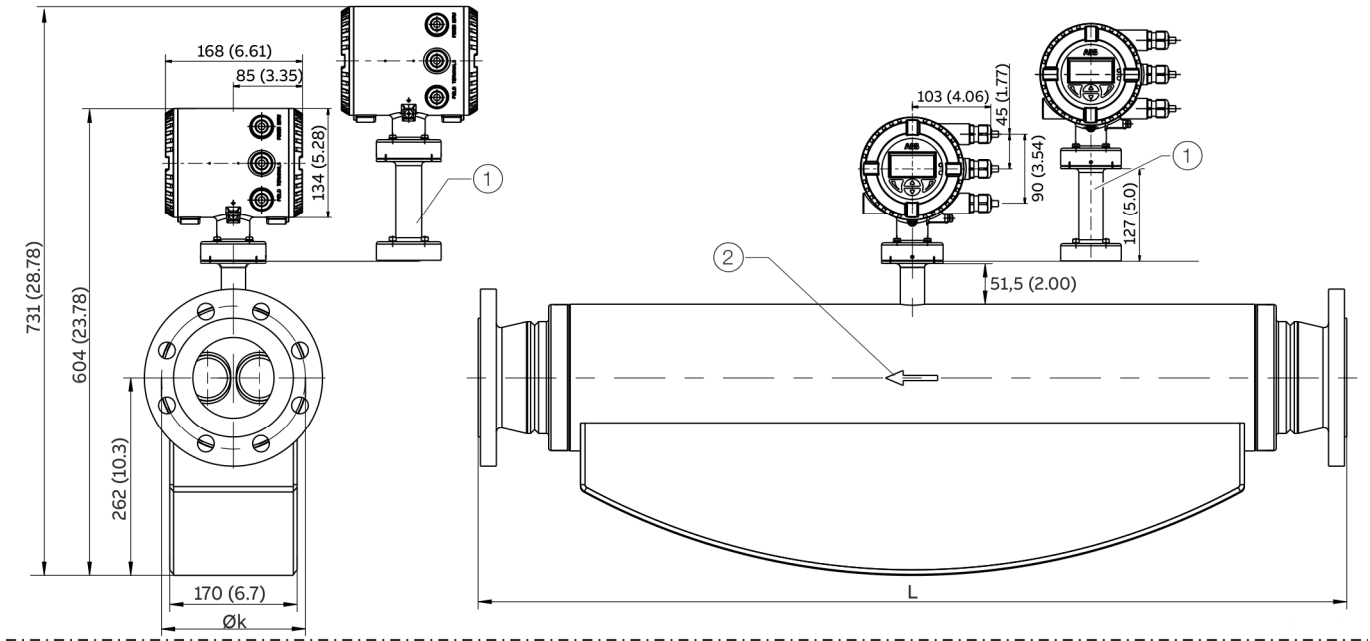

Marine version – CL1

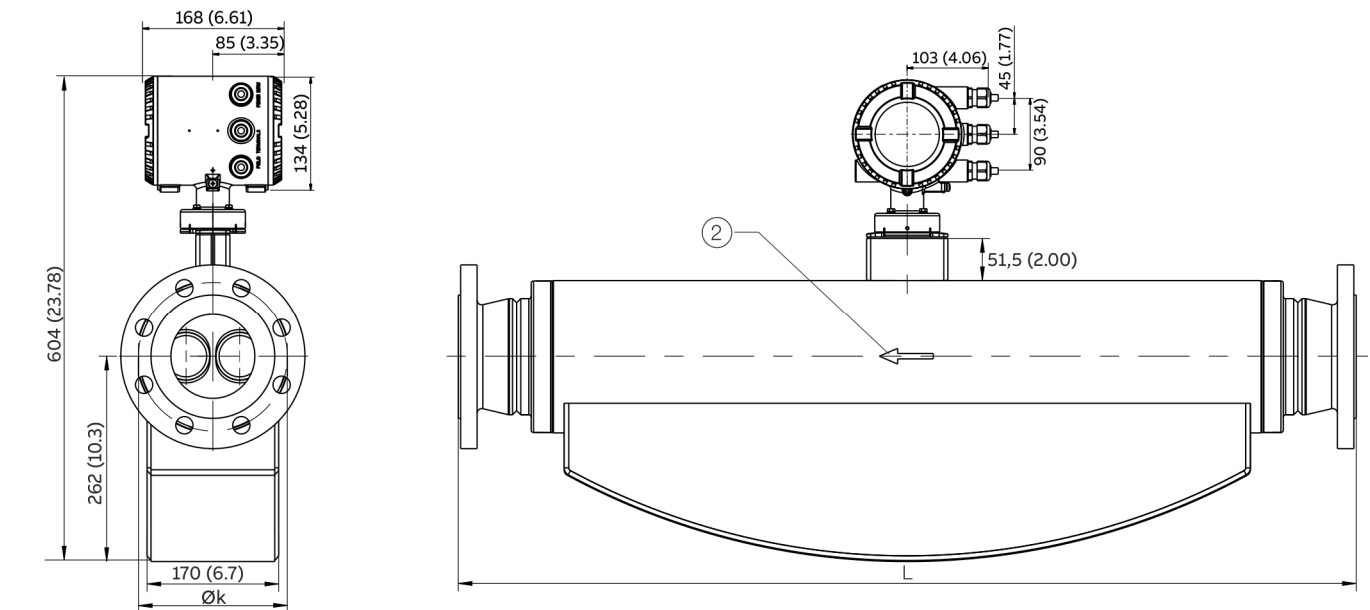

① 'Extended tower length – TE1, TE2' option or 'Pressure rating of sensor secondary housing – PR5, PR6, PR7' option

② Flow direction

Figure 3: Integral mount design with dual-compartment transmitter housing

Meter tube nominal diameter DN 100 (4 in)				
DN / process connection		L	Ø k	Weight max.
80 (3 in)	PN 16 (EN 1092-1 B1)	1222 (48.11)	160 (6.30)	126 (278)
	PN 40 (EN 1092-1 B1)			
	PN 63 (EN 1092-1 B2)	1234 (48.58)	170 (6.69)	130 (287)
	PN 100 (EN 1092-1 B2)		180 (7.09)	132 (291)
	CL150 (ASME B16.5)	1244 (48.98)	152.4 (6.00)	127 (280)
	CL300 (ASME B16.5)		168.1 (6.62)	135 (298)
	CL600 (ASME B16.5)		168.1 (6.62)	138 (304)
	CL900 (ASME B16.5)	1470 (57.87)	190.5 (7.50)	141 (311)
	CL1500 (ASME B16.5)	1500 (59.05)	203.2 (8.00)	153 (337)
	JIS 10K	1275 (50.20)	150 (5.91)	123 (271)
	JIS 16K	1275 (50,20)	150 (5,91)	123 (271)
	JIS 20K	1275 (50,20)	150 (5,91)	123 (271)
100 (4 in)	PN 16 (EN 1092-1 B1)	1122 (44.17)	180 (7.09)	123 (271)
	PN 40 (EN 1092-1 B1)	1144 (45.04)	190 (7.48)	126 (278)
	PN 63 (EN 1092-1 B2)	1304 (51.34)	138 (5.43)	133 (293)
	PN 100 (EN 1092-1 B2)	1334 (52.52)	150 (5.91)	141 (311)
	CL150 (ASME B16.5)	1144 (45.04)	190.5 (7.50)	127 (280)
	CL300 (ASME B16.5)	1324 (52.13)	200.2 (7.88)	139 (306)
	CL600 (ASME B16.5)	1354 (53.31)	215.9 (8.50)	141 (311)
	CL900 (ASME B16.5)	1380 (54.33)	234.9 (9.25)	160 (353)
	CL1500 (ASME B16.5)	1400 (55.12)	241.3 (9.50)	174 (384)
	JIS 10K	1150 (45.28)	175 (6.89)	126 (278)
	JIS 16K	1150 (45,28)	175 (6,89)	126 (278)
	JIS 20K	1150 (45,28)	175 (6,89)	126 (278)
150 (6 in)	PN 16 (EN 1092-1 B1)	1300 (51.18)	240 (9.44)	131 (289)
	PN 40 (EN 1092-1 B1)		250 (9.84)	139 (306)
	CL150 (ASME B16.5)	1330 (52.36)	241.3 (9.50)	137 (302)
	CL600 (ASME B16.5)	1435 (56.50)	-	-
	JIS 10K	1300 (51.18)	240 (9.44)	130 (287)
	JIS 16K	1300 (51,18)	240 (9,44)	130 (287)
	JIS 20K	1308 (51,50)	240 (9,44)	130 (287)

Tolerance for dimension L: +0 / -3 mm (+0 / -0.018 in)

... Flowmeter sensor

Devices with meter tube nominal diameter DN 150 and flange DN 100 to DN 200

Sensor with wetted parts made from stainless steel.

All dimensions and weights are specified in mm (in) or kg (lb).

Standard Version

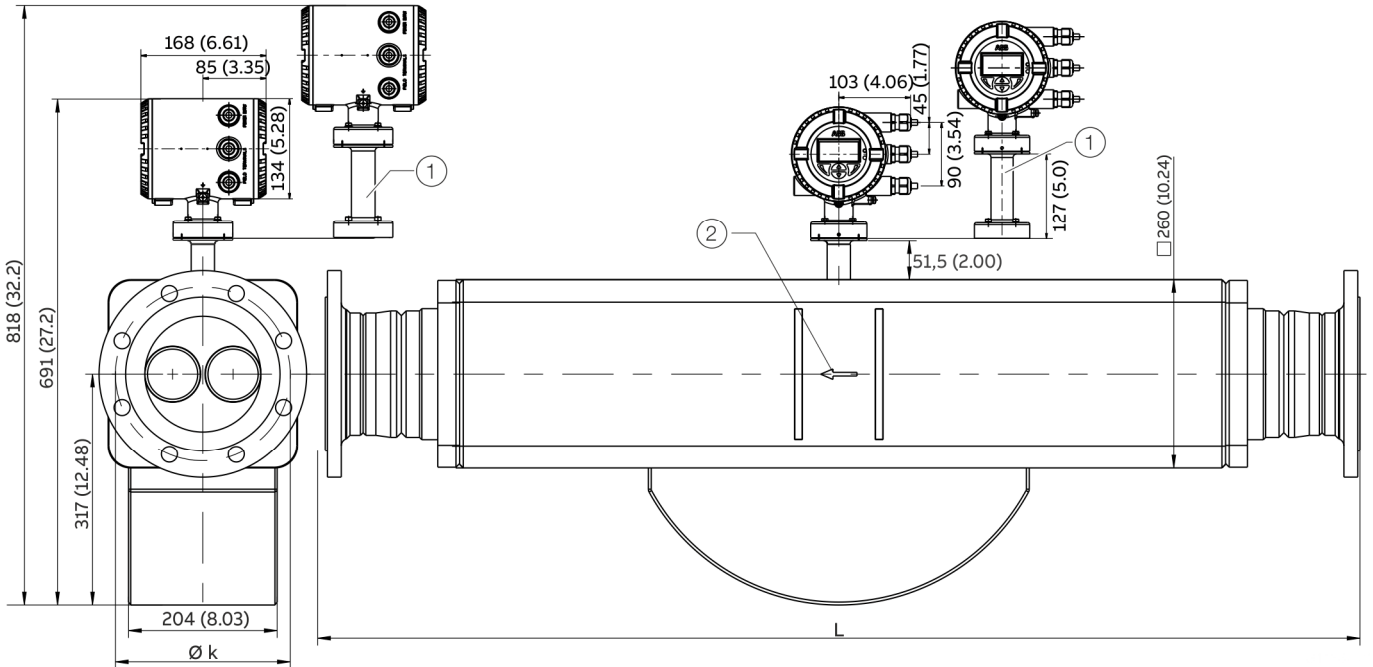

Marine version – CL1

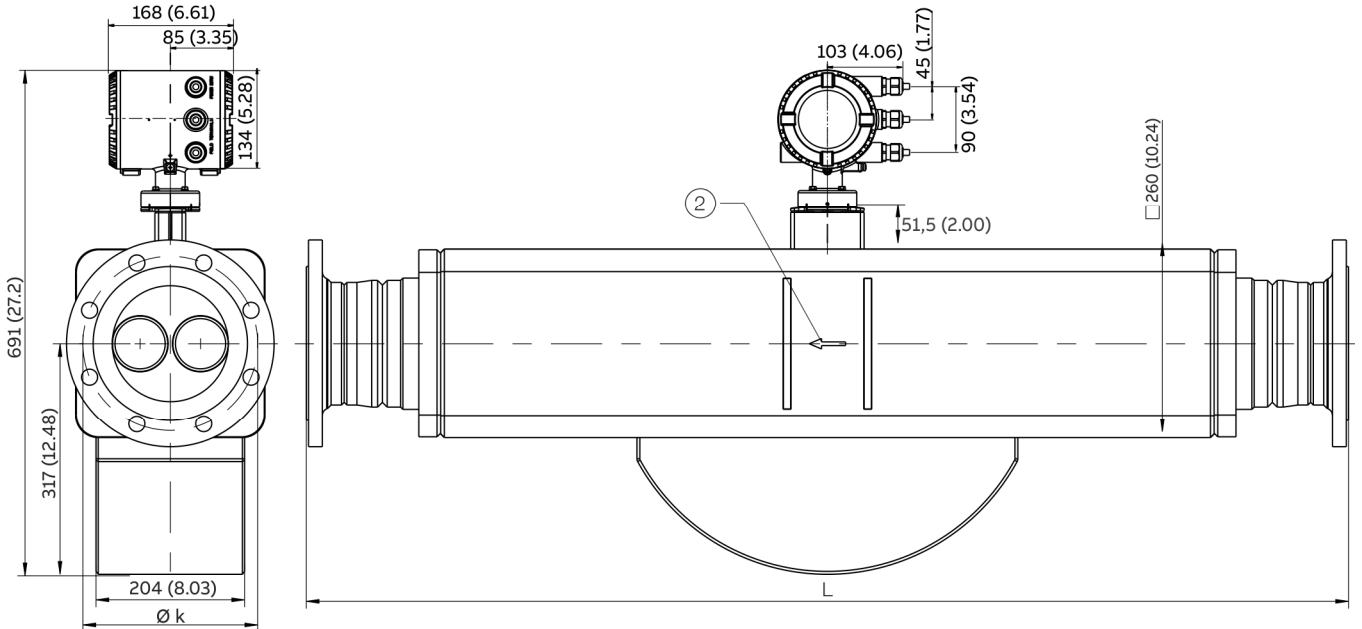

① 'Extended tower length – TE1, TE2' option or 'Pressure rating of sensor secondary housing – PR5, PR6, PR7' option

② Flow direction

Figure 4: Integral mount design with dual-compartment transmitter housing

Meter tube nominal diameter DN 150 (6 in)				
DN / process connection		L	Ø k	Weight max.
100 (4 in)	PN 16 (EN 1092-1 B1)	1569 (61.77)	180 (7.09)	175 (386)
	PN 40 (EN 1092-1 B1)	1599 (62.95)	190 (7.48)	179 (395)
	CL150 (ASME B16.5)	1630 (64.17)	190.5 (7.50)	182 (401)
	CL300 (ASME B16.5)	1650 (64.96)	200.2 (7.88)	188 (414)
	CL600 (ASME B16.5)	1675 (65.94)	215.9 (8.50)	198 (437)
	CL900 (ASME B16.5)	1705 (67.13)	234.9 (9.25)	208 (459)
	CL1500 (ASME B16.5)	1725 (67.91)	241.3 (9.50)	223 (492)
	JIS 10K	1485 (58.46)	175 (6.89)	179 (395)
	JIS 16K	1485 (58.46)	185 (7.28)	181 (399)
	JIS 20K	1485 (58.46)	185 (7.28)	181 (399)
150 (6 in)	PN 16 (EN 1092-1 B1)	1421 (55.94)	240 (9.45)	178 (392)
	PN 40 (EN 1092-1 B1)	1461 (57.52)	250 (9.84)	186 (410)
	CL150 (ASME B16.5)	1485 (58.46)	241.3 (9.50)	185 (408)
	CL300 (ASME B16.5)	1505 (59.25)	269.7 (10.62)	203 (448)
	CL600 (ASME B16.5)	1555 (61.22)	292.1 (11.50)	225 (496)
	CL900 (ASME B16.5)	1605 (63.19)	317.5 (12.5)	249 (549)
	CL1500 (ASME B16.5)	1665 (65.55)		291 (642)
	JIS 10K	1425 (56.10)	240 (9.45)	186 (410)
	JIS 16K	1456 (57.32)	260 (6.30)	187 (412)
	JIS 20K	1464 (57.64)	260 (6.30)	187 (412)
200 (8 in)	PN 40 (EN 1092-1 B1)	1637 (64.45)	320 (12.6)	209 (461)
	CL150 (ASME B16.5)	1650 (64.96)	298.5 (11.75)	204 (450)
	CL300 (ASME B16.5)	1670 (65.75)	330.2 (13.0)	229 (505)
	CL600 (ASME B16.5)	1730 (68.11)	-	-
	JIS10K	1585 (62.4)	290 (11.42)	209 (461)
	JIS 16K	1615 (63.58)	305 (12.01)	210 (463)
	JIS 20K	1623 (63.90)	305 (12.01)	210 (463)

Tolerance for dimension L: +0 / -3 mm (+0 / -0.018 in)

... Flowmeter sensor

Devices DN 15 to 150 in NAMUR standard installation lengths (order option S5, S7)

Sensor with wetted parts made from stainless steel.

Dimensions and weights are in mm (in.) and kg (lb).

Standard Version

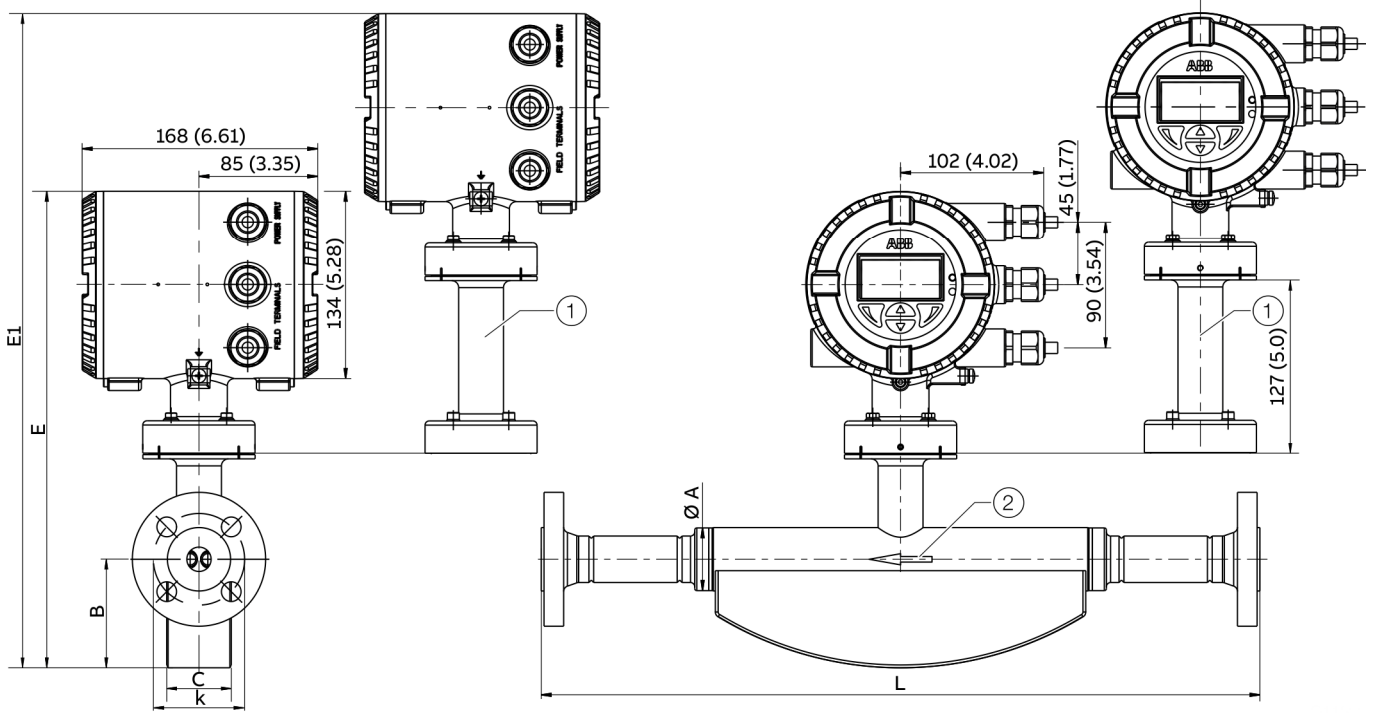

Marine version – CL1

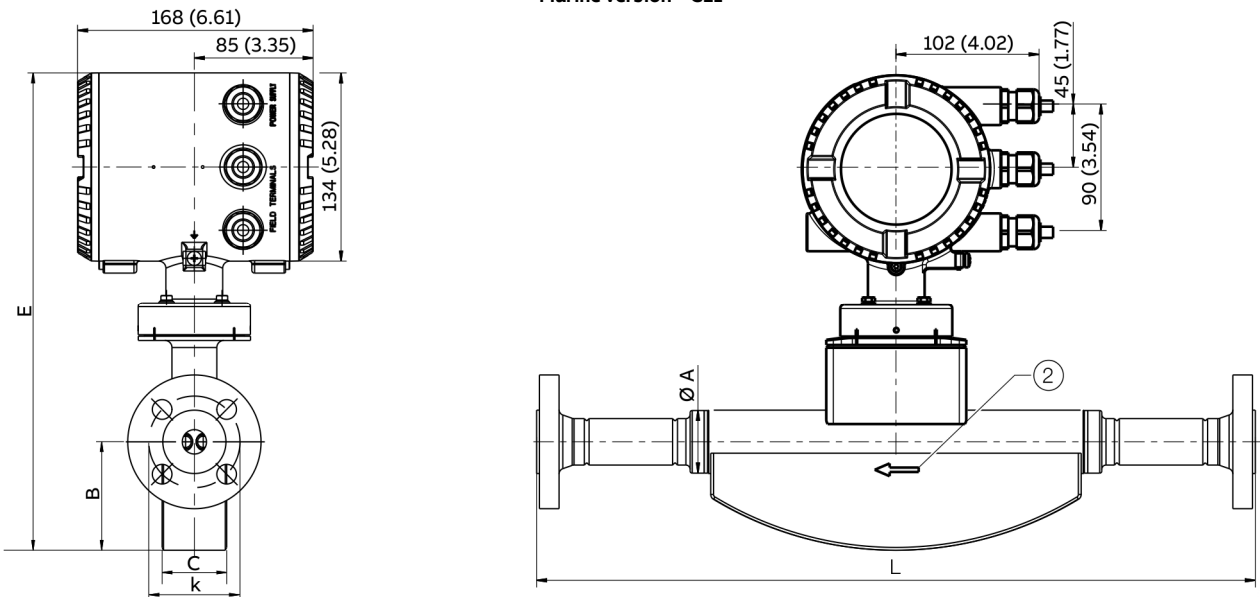

① 'Extended tower length – TE1, TE2' option or 'Pressure rating of sensor secondary housing – PR5, PR6, PR7' option

② Flow direction

Figure 5: Devices with integral mount design

Tolerance for dimension L: +0 / -3 mm (+0 / -0.018 in)

Devices DN 15 to 150 in NAMUR standard installation lengths

Meter tube	Process connection	L	Ø k	Ø A	B	C	E	E1*	Weight max.
EN 1092-1 B1									
DN 15 (½ in)	DN 15 (½ in) / PN 40	510 (20.08)	60 (2.4)	44.5 (1.8)	77 (3.0)	46 (1.8)	340 (13.39)	467 (18.39)	13.5 (29.8)
DN 25 (1 in)	DN 25 (1 in) / PN 40	600 (23.62)	75 (3.0)	69.5 (2.74)	103 (4.06)	62 (2.44)	379 (14.92)	506 (19.92)	15 (33.1)
DN 50 (1 in)	DN 50 (1 in) / PN 40	715 (28.15)	125 (4.92)	99 (3.9)	125 (4.92)	80 (3.15)	416 (16.38)	543 (21.38)	31 (68.3)
DN 80 (3 in)	DN 80 (3 in) / PN 40	915 (36.02)	160 (6.30)	155 (6.1)	183 (7.2)	123 (4.84)	505 (19.88)	632 (24.88)	74 (163)
DN 100 (4 in)	DN 100 (4 in) / PN 16	1400 (55.12)	180 (7.09)	195 (7.68)	261 (10.28)	168 (6.61)	603 (23.74)	730 (28.74)	123 (271)
DN 150 (6 in)	DN 150 (6 in) / PN 16	1700 (66.93)	240 (9.45)	260 (10.24)	320 (12.6)	205 (8.07)	691 (27.2)	818 (32.2)	178 (392)

* Standard version: devices with 'Extended tower length – TE1, TE2' or 'pressure rating of sensor secondary housing'.

Process connection in accordance with DIN 11851 meter tube nominal diameter DN 15 to 80 (½ to 3 in.)

Meter tube DN	Process connection		L	Ø DA	Ø Di	Ø A	B	C	E	Approximate weight									
	DN	PN								Aluminum*	Stainless steel**								
15 (½ in)	10 (⅜ in)	40	413 (16.3)	RD 28x⅝ in	10 (0.39)	44.5	77 (3.03)	46 (1.81)	340 / 467***	9 / 10***	12 / 13***								
	15 (½ in)			RD 34x⅝ in	16 (0.63)							(1.75)	(13.39 / 18.39***)	(20 / 22***)	(27 / 29***)				
	20 (¾ in)			RD 44x⅝ in	20 (0.79)														
25 (1 in)	20 (¾ in)	590 (23.2)	RD 44x⅝ in	20 (0.79)	69.5	103	62	379 / 506***	11 / 12***	14 / 15***									
	25 (1 in)			RD 52x⅝ in							26 (1.02)	(2.74)	(4.06)	(2.44)	(14.92 / 19.92***)	(24 / 27***)	(31 / 33***)		
	40 (1 ½ in)			RD 65x⅝ in							38 (1.5)								
50 (2 in)	40 (1 ½ in)	763 (30.0)	RD 65x⅝ in	38 (1.5)	99	125	80	416 / 543***	27 / 28***	30 / 31***									
	50 (2 in)			25							740 (29.1)	RD 78x⅝ in	50 (1.97)	(3.46)	(4.92)	(3.15)	(16.38 / 21.38***)	(60 / 62***)	(66 / 68***)
	65 (2 ½ in)			RD 95x⅝ in							66 (2.6)								
80 (3 in)	65 (2 ½ in)	990 (39.0)	RD 95x⅝ in	66 (2.6)	155	183	123	505 / 632***	68 / 69***	71 / 72***									
	80 (3 in)			940 (37.0)							RD 110x¾ in	81 (3.19)	(6.10)	(7.20)	(4.84)	(19.88 / 24.88***)	(150 / 152***)	(157 / 159***)	
	100 (4 in)			RD 130x¾ in							100 (3.94)								

Process connection in accordance with DIN 32676 meter tube nominal diameter DN 15 to 80 (½ to 3 in.)

Meter tube DN	Process connection		L	Ø DA	Ø Di	Ø A	B	C	E	Approximate weight									
	DN	PN								Aluminum*	Stainless steel**								
15 (½ in)	10 (⅜ in)	40	413 (16.3)	34 (1.34)	10 (0.39)	44.5	77 (3.03)	46 (1.81)	340 / 467***	9 / 10***	12 / 13***								
	15 (½ in)			16 (0.63)	(1.75)							(13.39 / 18.39***)	(20 / 22***)	(27 / 29***)					
	20 (¾ in)			20 (0.79)															
25 (1 in)	20 (¾ in)	590 (23.2)	RD 44x⅝ in	20 (0.79)	69.5	103	62	379 / 506***	11 / 12***	14 / 15***									
	25 (1 in)			50.5 (1.99)							26 (1.02)	(2.74)	(4.06)	(2.44)	(14.92 / 19.92***)	(24 / 27***)	(31 / 33***)		
	40 (1 ½ in)			38 (1.5)															
50 (2 in)	40 (1 ½ in)	763 (30.0)	RD 65x⅝ in	38 (1.5)	99	125	80	416 / 543***	27 / 28***	30 / 31***									
	50 (2 in)			25							740 (29.1)	64 (2.52)	50 (1.97)	(3.46)	(4.92)	(3.15)	(16.38 / 21.38***)	(60 / 62***)	(66 / 68***)
	65 (2 ½ in)			91 (3.58)							66 (2.6)								
80 (3 in)	65 (2 ½ in)	10	950 (37.4)	66 (2.6)	155	183	123	505 / 632***	68 / 69***	71 / 72***									
	80 (3 in)			910 (35.83)							106 (4.17)	81 (3.19)	(6.10)	(7.20)	(4.84)	(19.88 / 24.88***)	(150 / 152***)	(157 / 159***)	
	100 (4 in)			119 (4.69)							100 (3.94)								

* Devices with terminal boxes made from aluminum.

** Devices with terminal boxes made from stainless steel.

*** Devices with 'Extended tower length' option or 'Pressure rating of sensor secondary housing' option.

Tolerance for dimension L: +0 / -3 mm (+0 / -0.018 in)

... Flowmeter sensor

Process connection in accordance with ASME BPE, meter tube nominal diameter DN 15 to 80 (½ to 3 in.)												
Meter tube DN	Process connection		L	Ø DA	Ø Di	Ø A	B	C	E	Approximate weight		
	DN	PN								Aluminum ¹	Stainless steel ²	
15 (½ in)	¾ in Type A	10	–	–	–	44.5	77	46	340 / 467 ³	9 / 10 ³	12 / 13 ³	
	½ in Type A	433 (17.05)	25 (0.98)	9.4 (0.37)		(1.75)	(3.03)	(1.81)	(13.39 / 18.39 ³)	(20 / 22 ³)	(27 / 29 ³)	
	¾ in Type A		–	–	–							
25 (1 in)	¾ in Type A		–	–	–	69.5	103	62	379 / 506 ³	11 / 12 ³	14 / 15 ³	
	1 in Type B	590 (23.23)	50.4 (1.98)	22.1 (0.87)		(2.74)	(4.06)	(2.44)	(14.92 / 19.92 ³)	(24 / 27 ³)	(31 / 33 ³)	
	1½ in Type B	590 (23.23)	50.4 (1.98)	34.8 (1.37)								
50 (2 in)	1½ in Type B		–	–	–	99	125	80	416 / 543 ³	27 / 28 ³	30 / 31 ³	
	2 in Type B	740 (29.13)	63.9 (2.52)	47.5 (1.87)		(3.46)	(4.92)	(3.15)	(16.38 / 21.38 ³)	(60 / 62 ³)	(66 / 68 ³)	
	2½ in Type B		–	–	–							
80 (3 in)	2½ in Type B	950 (37.40)	77.4 (3.05)	60.2 (2.37)		155	183	183	505 / 632 ³	68 / 69 ³	71 / 72 ³	
	3 in Type B	910 (35.83)	90.9 (3.19)	72.9 (2.87)		(6.10)	(7.20)	(7.20)	(19.88 / 24.88 ³)	(150 / 152 ³)	(157 / 159 ³)	
	4 in Type B	910 (35.83)	118.9 (4.68)	97.4 (3.83)								

Process connection in accordance with DIN ISO 228 and ASME B 1.20.1, meter tube nominal diameter DN 15 to 80 (½ to 3 in)												
Meter tube DN	Process connection		L	GL	WS ⁴	SWL	Ø A	B	C	E	Approximate weight	
	DN / G	PN									Aluminum ¹	Stainless steel ²
15 (½ in)	8 (¼ in) / G ¼ in	100	450	10 (0.39)	19	10 (0.39)	44.5	77 (3.03)	46 (1.81)	340 / 467 ³	9 / 10 ³	12 / 13 ³
			(17.72)				(1.75)			(13.39 / 18.39 ³)	(20 / 22 ³)	(27 / 29 ³)
	15 (½ in) / G ½ in.			13.5 (0.53)	27	15 (0.59)						
		25 (1 in) / G 1 in		490	17 (0.67)	50	20 (0.79)					
			(19.29)									
	15 (½ in.) / ½ in NPT		450	15.6 (0.61)	27	15 (0.59)						
			(17.72)									

¹ Devices with terminal boxes made from aluminum.

² Devices with terminal boxes made from stainless steel.

³ Devices with 'Extended tower length' option or 'Pressure rating of sensor secondary housing' option.

⁴ Dimension WS: Width across flats specified in mm.

Tolerance for dimension L: +0 / –3 mm (+0 / –0.018 in)

Dimensions for devices with remote mount design

Devices with meter tube nominal diameter DN 15 to 50 and flange DN 10 to 65

Sensor with wetted parts made from stainless steel.

All dimensions and weights are specified in mm (in) or kg (lb).

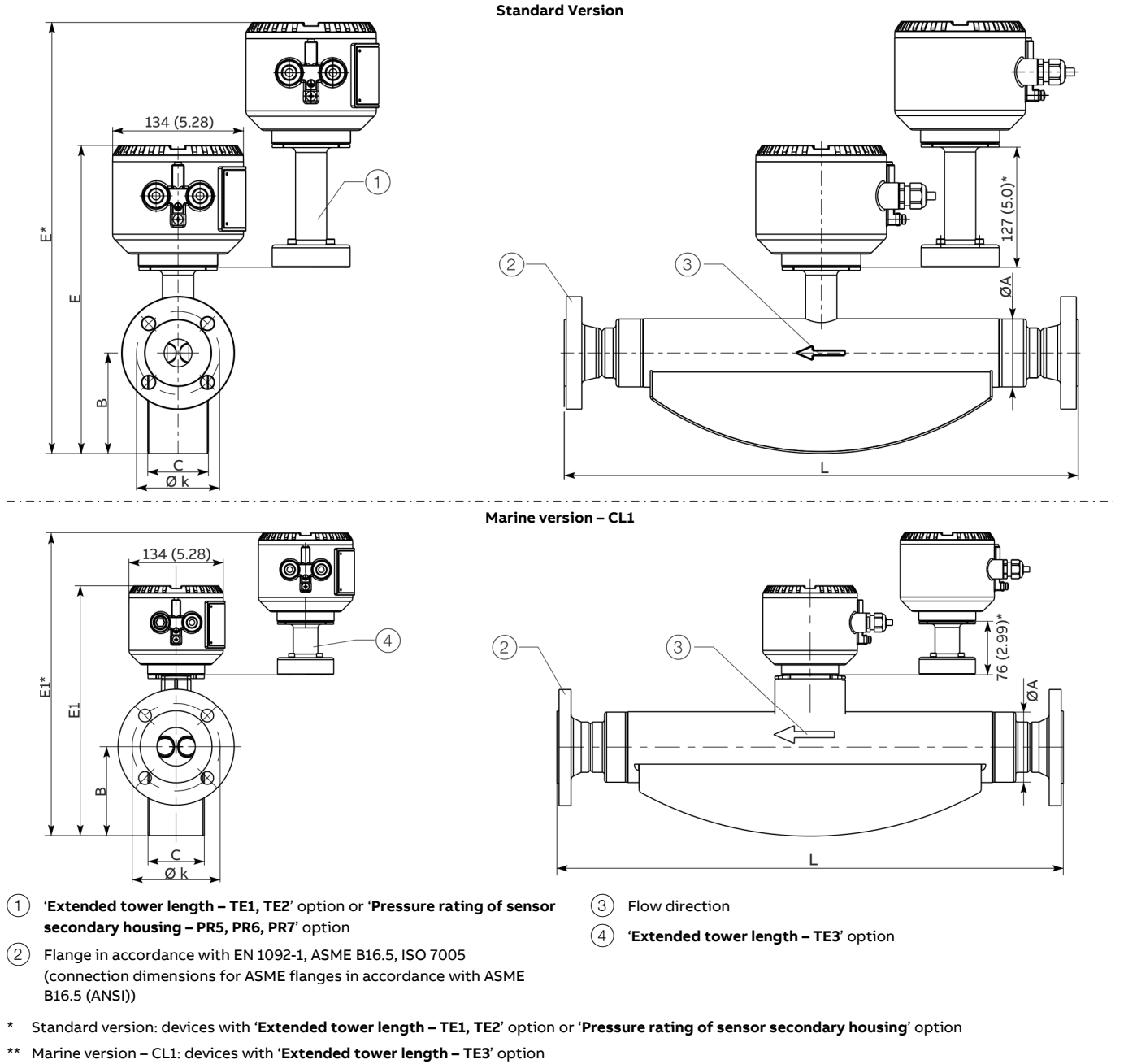

Figure 6: Remote mount design

... Flowmeter sensor

Meter tube nominal diameter DN 15 (½ in)										
DN / process connection		L	Ø k	Ø A	B	C	E	E1	Weight max.	
10 (¾ in)	PN 40 (EN 1092-1 B1)	385 (15.2)	60 (2.4)	44.5 (1.8)	80 (3.2)	49 (1.93)	283 (11.1)	410*	283 (11.1)	13 (28.7)
	JIS 10K	385 (15.2)	65 (2.6)				(16.1*)	357** (14.1**)		
	JIS 16K	385 (15.2)	65 (2.6)							
	JIS 20K	385 (15.2)	65 (2.6)							
15 (½ in)	PN 40 (EN 1092-1 B1)	385 (15.2)	65 (2.6)							
	PN 63 (EN 1092-1 B2)	403 (15.9)	75 (3.0)							
	PN 100 (EN 1092-1 B2)									
	CL150 (ASME B16.5)	435 (17.1)	60.5 (2.4)							
	CL300 (ASME B16.5)	421 (16.6)	66.5 (2.6)							
	CL600 (ASME B16.5)									
	CL900 (ASME B16.5)	421 (16.6)	82.6 (3.3)							
	CL1500 (ASME B16.5)									
	JIS 10K	385 (15.2)	70 (2.8)							
	JIS 16K	385 (15.2)	70 (2.8)							
JIS 20K	385 (15.2)	70 (2.8)								
20 (¾ in)	PN 40 (EN 1092-1 B1)	421 (16.6)	75 (3.0)							
	CL150 (ASME B16.5)	421 (16.6)	69.9 (2.8)							
	JIS 10K	421 (16.6)	75 (3.0)							
	JIS 16K	385 (15.2)	75 (3.0)							
	JIS 20K	385 (15.2)	75 (3.0)							

Meter tube nominal diameter DN 25 (1 in)									
DN / process connection		L	Ø k	Ø A	B	C	E	E1	Weight max.
20 (¾ in)	PN 40 (EN 1092-1 B1)	576 (22.7)	75 (3.0)	69.5 (2.74)	103 (4.06)	62 (2.44)	324 (12.8)	324 (12.8)	15 (33.1)
	CL150 (ASME B16.5)	575 (22.6)	69.9 (2.8)				451* (17.8*)	398** (15.7**)	
	JIS 10K	576 (22.7)	75 (3.0)						
	JIS 16K	576 (22.7)	75 (3.0)						
	JIS 20K	576 (22.7)	75 (3.0)						
25 (1 in)	PN 40 (EN 1092-1 B1)	525 (20.7)	85 (3.3)						
	PN 63 (EN 1092-1 B2)	564 (22.2)	100 (3.9)						
	PN 100 (EN 1092-1 B2)								
	CL150 (ASME B16.5)	575 (22.6)	79.2 (3.1)						
	CL300 (ASME B16.5)	576 (22.7)	88.9 (3.5)						
	CL600 (ASME B16.5)								
	CL900 (ASME B16.5)	576 (22.7)	101.6 (4.0)						
	CL1500 (ASME B16.5)								
	JIS 10K	525 (20.7)	90 (3.54)						
	JIS 16K	525 (20.7)	90 (3.54)						
JIS 20K	525 (20.7)	90 (3.54)							
40 (1½ in)	PN 40 (EN 1092-1 B1)	576 (22.7)	110 (4.33)						
	PN 63 (EN 1092-1 B2)	572 (22.5)	125 (4.92)						
	PN 100 (EN 1092-1 B2)								
	CL150 (ASME B16.5)	576 (22.7)	98.6 (3.88)						
	CL300 (ASME B16.5)	576 (22.7)	114.3 (45.0)						
	CL600 (ASME B16.5)								
	JIS 10K	576 (22.7)	105 (4.13)						
	JIS 16K	576 (22.7)	105 (4.13)						
JIS 20K	576 (22.7)	105 (4.13)							

* Standard version: devices with 'Extended tower length – TE1, TE2' option or 'Pressure rating of sensor secondary housing' option

** Marine version – CL1: devices with 'Extended tower length – TE3' option

Tolerance for dimension L: +0 / -3 mm (+0 / -0.018 in)

... Flowmeter sensor

Meter tube nominal diameter DN 50 (2 in)									
DN / process connection		L	Ø k	Ø A	B	C	E	E1	Weight max.
40 (1½ in)	PN 40 (EN 1092-1 B1)	763 (30)	110 (4.33)	99 (3.9)	126 (4.96)	80 (3.15)	354 (13.9)	354 (13.9)	31 (68.3)
	PN 63 (EN 1092-1 B2)	745 (29.33)	125 (4.92)				481* (18.94*)	428** (16.9**)	
	PN 100 (EN 1092-1 B2)								
	CL150 (ASME B16.5)	763 (30)	98.6 (3.88)						
	CL300 (ASME B16.5)	756 (29.76)	114.3 (4.5)						
	CL600 (ASME B16.5)								
	CL900 (ASME B16.5)	780 (30.71)	124 (4.88)						
	CL1500 (ASME B16.5)								
	JIS 10K	763 (30)	105 (4.13)						
	JIS 16K	763 (30)	105 (4.13)						
	JIS 20K	763 (30)	105 (4.13)						
	50 (2 in)	PN 40 (EN 1092-1 B1)	715 (28.15)	125 (4.92)					
PN 63 (EN 1092-1 B2)		745 (29.3)	135 (5.31)						
PN 100 (EN 1092-1 B2)		757 (29.80)	145 (5.71)						
CL150 (ASME B16.5)		715 (28.15)	120.7 (4.75)						
CL300 (ASME B16.5)		763 (30)	127 (5.0)						
CL600 (ASME B16.5)		773 (30.43)	127 (5.0)						
CL900 (ASME B16.5)		790 (31.1)	165.1 (6.5)						
CL1500 (ASME B16.5)									
JIS 10K		715 (28.15)	120 (4.72)						
JIS 16K		715 (28,15)	120 (4.72)						
JIS 20K		715 (28,15)	120 (4.72)						
65 (2½ in)		PN 40 (EN 1092-1 B1)	763 (30)	145 (5.71)					
	CL150 (ASME B16.5)	756 (29.8)	139.7 (5.5)						
	CL900 (ASME B16.5)	800 (31.5)	190.5 (7.5)						
	CL1500 (ASME B16.5)								
	JIS 10K	763 (30)	140 (5.51)						
	JIS 16K	763 (30)	140 (5.51)						
JIS 20K	763 (30)	140 (5.51)							

* Standard version: devices with 'Extended tower length – TE1, TE2' option or 'Pressure rating of sensor secondary housing' option

** Marine version – CL1: devices with 'Extended tower length – TE3' option

Tolerance for dimension L: +0 / -3 mm (+0 / -0.018 in)

Devices with meter tube nominal diameter DN 80 and flange DN 65 to 100

Sensor with wetted parts made from stainless steel.

All dimensions and weights are specified in mm (in) or kg (lb).

Standard Version

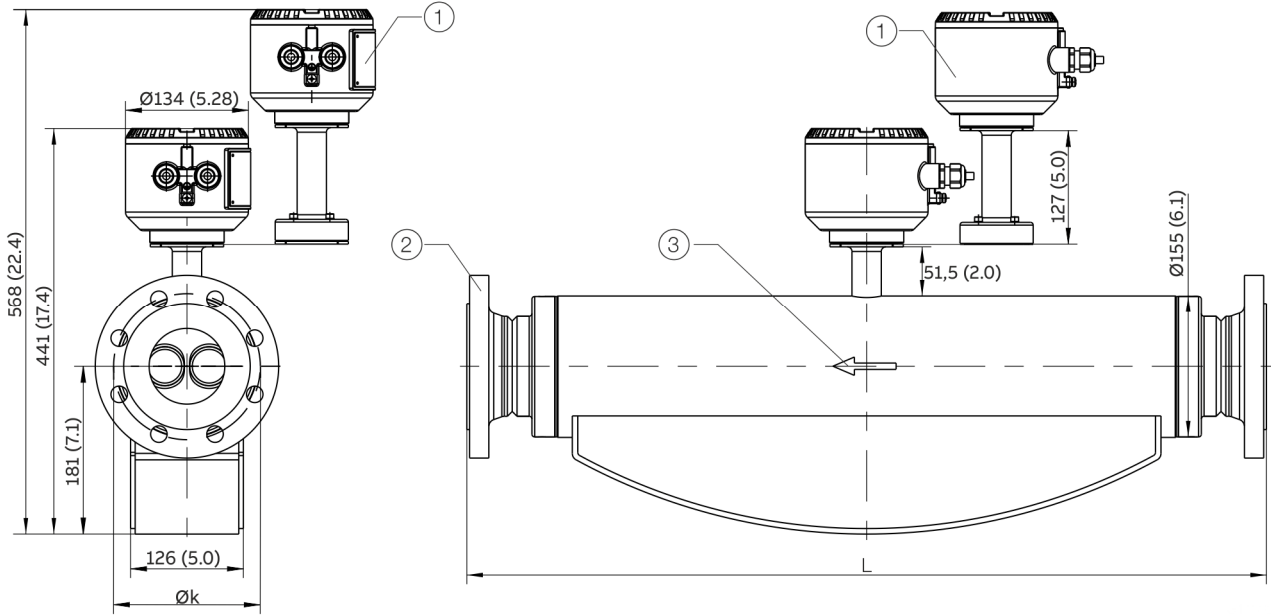

Marine version – CL1

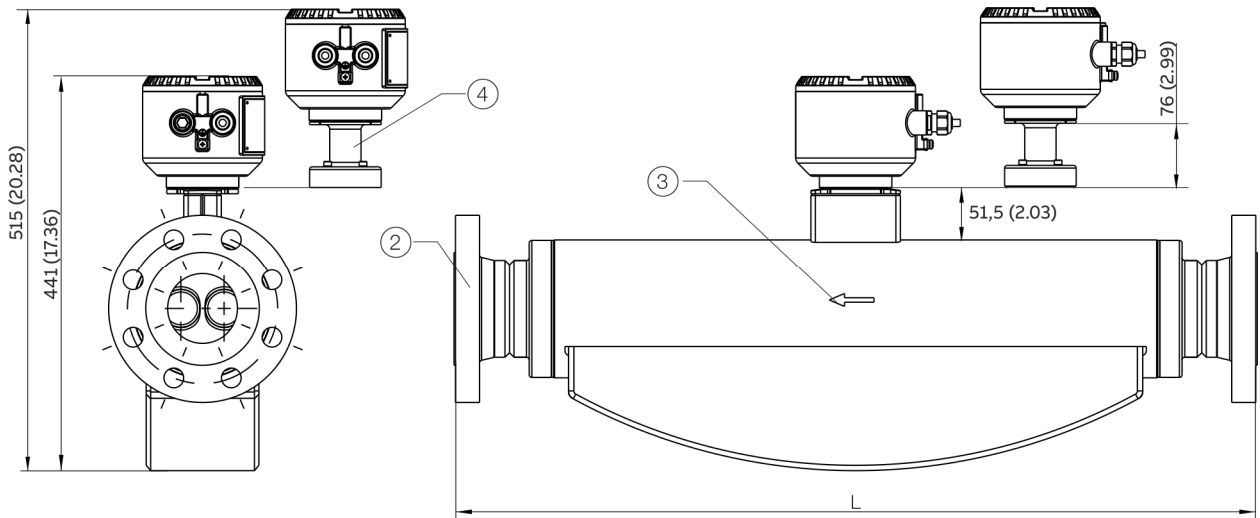

- ① 'Extended tower length – TE1, TE2' option or 'Pressure rating of sensor secondary housing – PR5, PR6, PR7' option
- ② Flange in accordance with EN 1092-1, ASME B16.5, ISO 7005 (connection dimensions for ASME flanges in accordance with ASME B16.5 (ANSI))
- ③ Flow direction
- ④ 'Extended tower length – TE3' option

Figure 7: Remote mount design

... Flowmeter sensor

Meter tube nominal diameter DN 80 (3 in)				
DN / process connection		L	Ø k	Weight max.
65 (2½ in)	PN 16 (EN 1092-1 B1)	—*	—*	—*
	PN 40 (EN 1092-1 B1)	910 (35.83)	145 (5.71)	74 (163.1)
	PN 63 (EN 1092-1 B2)		160 (6.3)	78 (172.0)
	PN 100 (EN 1092-1 B2)		170 (6.69)	82 (180.8)
	CL150 (ASME B16.5)	920 (36.22)	—*	—*
	CL300 (ASME B16.5)	920 (36.22)	149.4 (5.88)	76 (167.6)
	CL600 (ASME B16.5)			77 (169.8)
	CL900 (ASME B16.5)	965 (37.99)	190.5 (7.5)	94 (207.2)
	CL1500 (ASME B16.5)			
	JIS 10K	910 (35.83)	140 (5.5)	74 (163.1)
JIS 16K	910 (35.83)	140 (5.5)	74 (163.1)	
JIS 20K	920 (36.22)	140 (5.5)	74 (163.1)	
80 (3 in)	PN 16 (EN 1092-1 B1)	870 (34.25)	160 (6.30)	74 (163.1)
	PN 40 (EN 1092-1 B1)			75 (165.4)
	PN 63 (EN 1092-1 B2)	910 (35.83)	170 (6.69)	79 (174.2)
	PN 100 (EN 1092-1 B2)		180 (7.09)	85 (187.4)
	CL150 (ASME B16.5)	880 (34.65)	152.4 (6.00)	76 (165.4)
	CL300 (ASME B16.5)	895 (35.24)	168.1 (6.62)	79 (174.2)
	CL600 (ASME B16.5)	920 (36.22)		82 (180.8)
	CL900 (ASME B16.5)	1100 (43.31)	190.5 (7.50)	94 (207.2)
	CL1500 (ASME B16.5)	1300 (51.18)	203.2 (8.00)	106 (233.7)
	JIS 10K	870 (34.25)	150 (5.91)	75 (165.4)
JIS 16K	870 (34.25)	150 (5.91)	75 (165.4)	
JIS 20K	910 (35.83)	150 (5.91)	75 (165.4)	
100 (4 in)	PN 16 (EN 1092-1 B1)	875 (34.45)	180 (7.09)	75 (165.4)
	PN 40 (EN 1092-1 B1)		190 (7.48)	76 (167.5)
	PN 63 (EN 1092-1 B2)	1060 (41.73)	200 (7.87)	86 (189.6)
	PN 100 (EN 1092-1 B2)	1080 (42.52)	210 (8.27)	94 (207.2)
	CL150 (ASME B16.5)	880 (34.65)	190.5 (7.50)	77 (169.8)
	CL300 (ASME B16.5)	1075 (42.32)	200.2 (7.88)	91 (200.6)
	CL600 (ASME B16.5)	1100 (43.31)	215.9 (8.50)	101 (222.7)
	CL900 (ASME B16.5)	1130 (44.49)	234.9 (9.25)	111 (244.7)
	CL1500 (ASME B16.5)	1150 (45.28)	241.3 (9.50)	126 (277.8)
	JIS 10K	1060 (41.73)	175 (6.86)	86 (189.6)
JIS 16K	1060 (41.73)	175 (6.86)	85 (187.4)	
JIS 20K	1060 (41.73)	175 (6.86)	85 (187.4)	

* On request

Tolerance for dimension L: +0 / -3 mm (+0 / -0.018 in)

Devices with meter tube nominal diameter DN 100 and flange DN 80 to 100

Sensor with wetted parts made from stainless steel.

All dimensions and weights are specified in mm (in) or kg (lb).

Standard Version

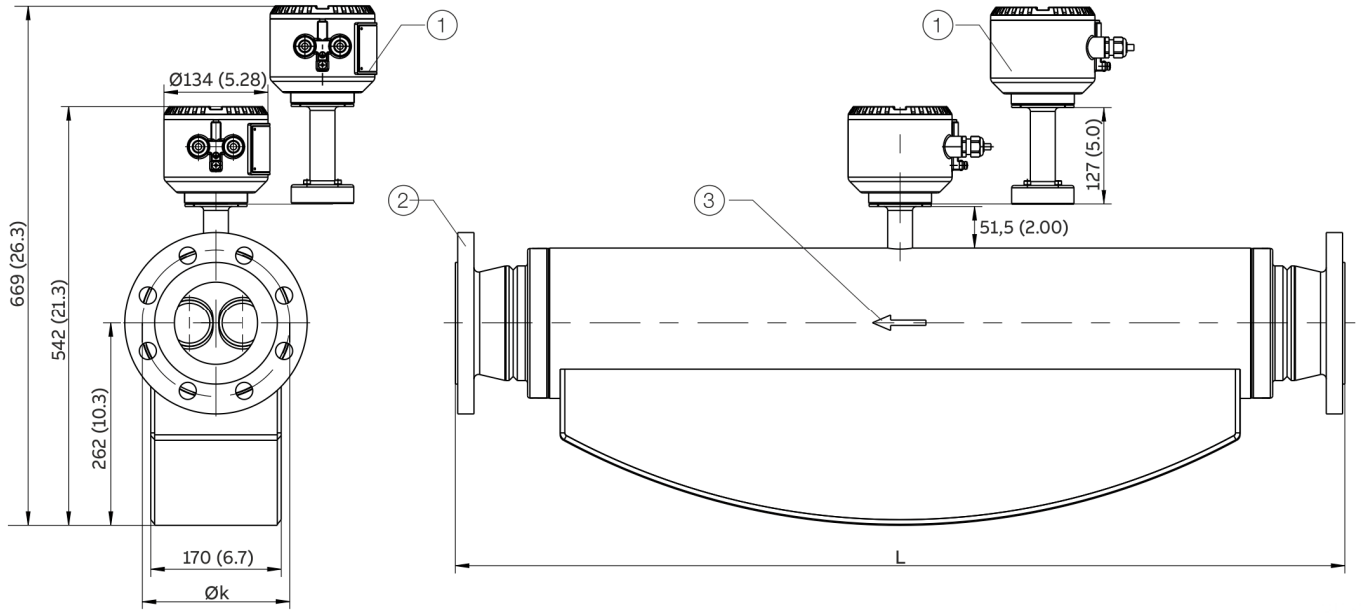

Marine version – CL1

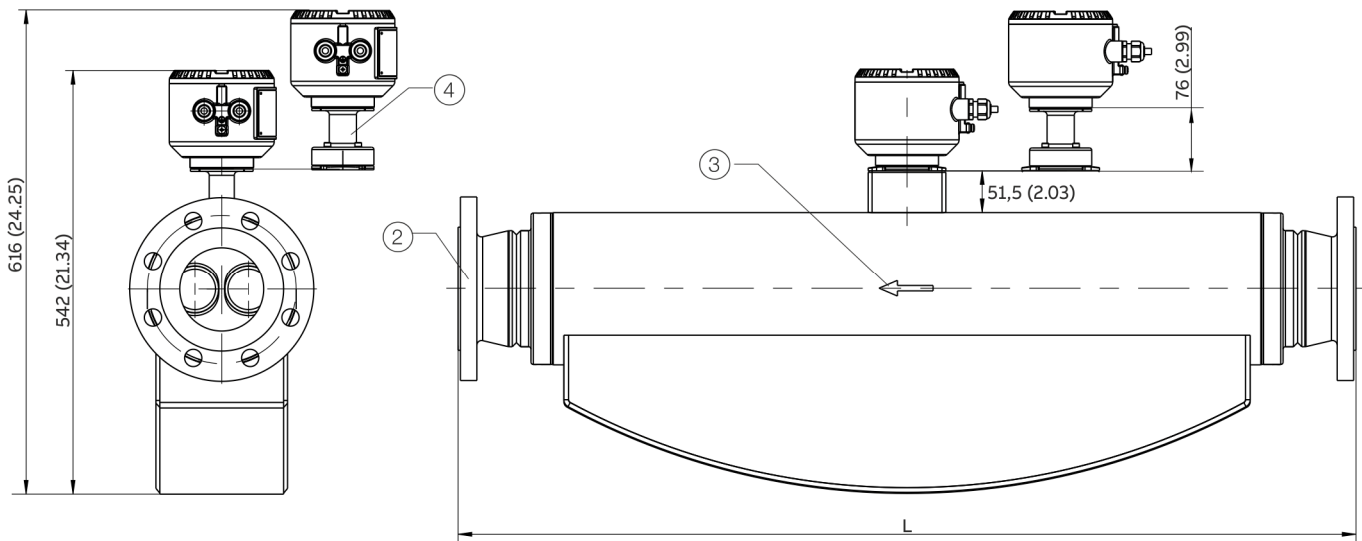

- ① 'Extended tower length – TE1, TE2' option or 'Pressure rating of sensor secondary housing – PR5, PR6, PR7' option
- ② Flange in accordance with EN 1092-1, ASME B16.5, ISO 7005 (connection dimensions for ASME flanges in accordance with ASME B16.5 (ANSI))
- ③ Flow direction
- ④ 'Extended tower length – TE3' option

Figure 8: Remote mount design

... Flowmeter sensor

Meter tube nominal diameter DN 100 (4 in)				
DN / process connection		L	Ø k	Weight max.
80 (3 in)	PN 16 (EN 1092-1 B1)	1222 (48.11)	160 (6.30)	126 (278)
	PN 40 (EN 1092-1 B1)			126 (278)
	PN 63 (EN 1092-1 B2)	1234 (48.58)	170 (6.69)	130 (287)
	PN 100 (EN 1092-1 B2)		180 (7.09)	132 (291)
	CL150 (ASME B16.5)	1244 (48.98)	152.4 (6.00)	127 (280)
	CL300 (ASME B16.5)		168.1 (6.62)	135 (298)
	CL600 (ASME B16.5)		168.1 (6.62)	138 (304)
	CL900 (ASME B16.5)	1470 (57.87)	190.5 (7.50)	141 (311)
	CL1500 (ASME B16.5)	1500 (59.05)	203.2 (8.00)	153 (337)
	JIS 10K	1275 (50.20)	150 (5.91)	123 (271)
	JIS 16K	1275 (50.20)	150 (5.91)	123 (271)
	JIS 20K	1275 (50.20)	150 (5.91)	123 (271)
100 (4 in)	PN 16 (EN 1092-1 B1)	1122 (44.17)	180 (7.09)	123 (271)
	PN 40 (EN 1092-1 B1)	1144 (45.04)	190 (7.48)	126 (278)
	PN 63 (EN 1092-1 B2)	1304 (51.34)	138 (5.43)	133 (293)
	PN 100 (EN 1092-1 B2)	1334 (52.52)	150 (5.91)	141 (311)
	CL150 (ASME B16.5)	1144 (45.04)	190.5 (7.50)	127 (280)
	CL300 (ASME B16.5)	1324 (52.13)	200.2 (7.88)	139 (306)
	CL600 (ASME B16.5)	1354 (53.31)	215.9 (8.50)	141 (311)
	CL900 (ASME B16.5)	1380 (54.33)	234.9 (9.25)	160 (353)
	CL1500 (ASME B16.5)	1400 (55.12)	241.3 (9.50)	174 (384)
	JIS 10K	1150 (45.28)	175 (6.89)	126 (278)
	JIS 16K	1150 (45.28)	175 (6.89)	126 (278)
	JIS 20K	1150 (45.28)	175 (6.89)	126 (278)
150 (6 in)	PN 16 (EN 1092-1 B1)	1300 (51.18)	240 (9.44)	131 (289)
	PN 40 (EN 1092-1 B1)	1330 (52.36)	250 (9.84)	139 (306)
	CL150 (ASME B16.5)		241.3 (9.50)	137 (302)
	CL600 (ASME B16.5)	1435 (56.50)	-	-
	JIS 10K	1300 (51.18)	240 (9,44)	130 (287)
	JIS 16K	1300 (51.18)	240 (9,44)	130 (287)
	JIS 20K	1308 (51.50)	240 (9,44)	130 (287)

Tolerance for dimension L: +0 / -3 mm (+0 / -0.018 in)

Devices with meter tube nominal diameter DN 150 and flange DN 100 to DN 200

Sensor with wetted parts made from stainless steel.

All dimensions and weights are specified in mm (in) or kg (lb).

Standard Version

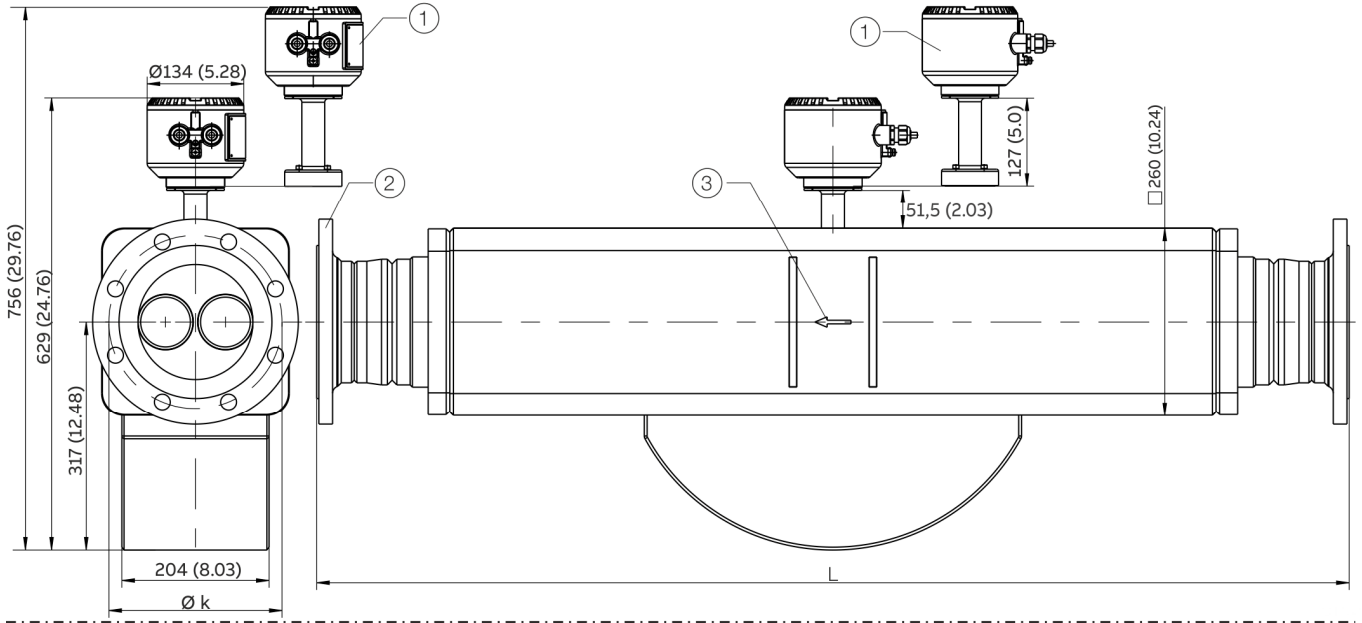

Marine version – CL1

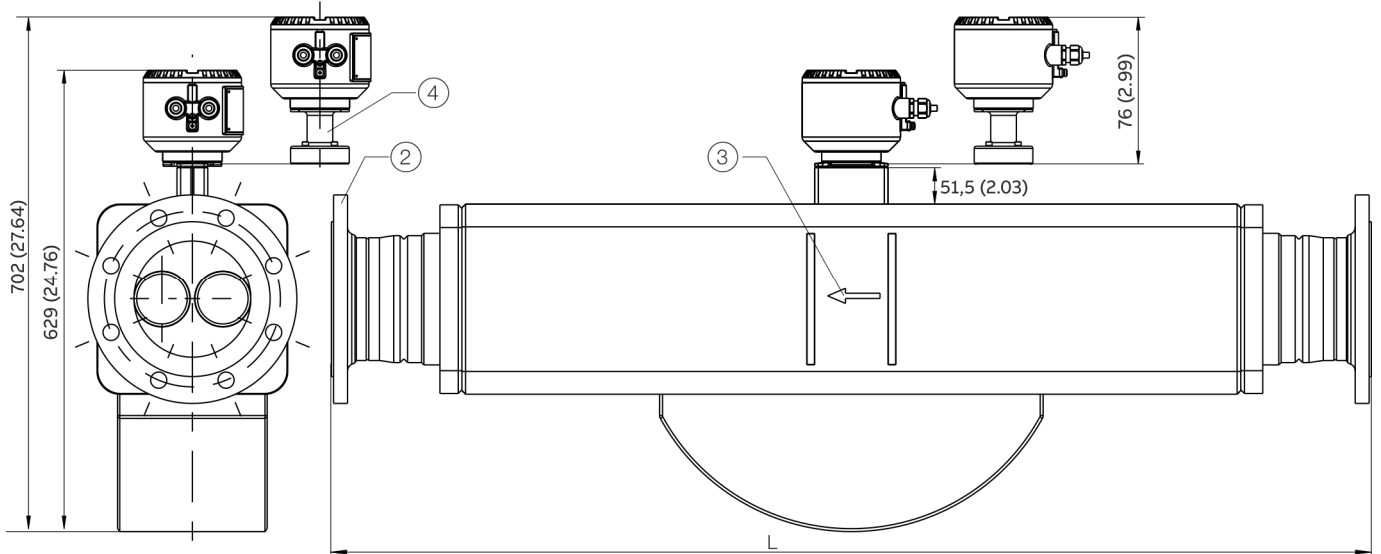

- ① 'Extended tower length – TE1, TE2' option or 'Pressure rating of sensor secondary housing – PR5, PR6, PR7' option
- ② Flange in accordance with EN 1092-1, ASME B16.5, ISO 7005 (connection dimensions for ASME flanges in accordance with ASME B16.5 (ANSI))
- ③ Flow direction
- ④ 'Extended tower length – TE3' option

Figure 9: Remote mount design

... Flowmeter sensor

Meter tube nominal diameter DN 150 (6 in)				
DN / process connection		L	Ø k	Weight max.
100 (4 in)	PN 16 (EN 1092-1 B1)	1569 (61.77)	180 (7.09)	175 (386)
	PN 40 (EN 1092-1 B1)	1599 (62.95)	190 (7.48)	179 (395)
	CL150 (ASME B16.5)	1630 (64.17)	190.5 (7.50)	182 (401)
	CL300 (ASME B16.5)	1650 (64.96)	200.2 (7.88)	188 (414)
	CL600 (ASME B16.5)	1675 (65.94)	215.9 (8.50)	198 (437)
	CL900 (ASME B16.5)	1705 (67.13)	234.9 (9.25)	208 (459)
	CL1500 (ASME B16.5)	1725 (67.91)	241.3 (9.50)	223 (492)
	JIS 10K	1485 (58.46)	175 (6.89)	179 (395)
	JIS 16K	1485 (58.46)	185 (7.28)	181 (399)
	JIS 20K	1485 (58.46)	185 (7.28)	181 (399)
150 (6 in)	PN 16 (EN 1092-1 B1)	1421 (55.94)	240 (9.45)	178 (392)
	PN 40 (EN 1092-1 B1)	1461 (57.52)	250 (9.84)	186 (410)
	CL150 (ASME B16.5)	1485 (58.46)	241.3 (9.50)	185 (408)
	CL300 (ASME B16.5)	1505 (59.25)	269.7 (10.62)	203 (448)
	CL600 (ASME B16.5)	1555 (61.22)	292.1 (11.50)	225 (496)
	CL900 (ASME B16.5)	1605 (63.19)	317.5 (12.5)	249 (549)
	CL1500 (ASME B16.5)	1665 (65.55)		291 (642)
	JIS 10K	1425 (56.10)	240 (9.45)	186 (410)
	JIS 16K	1456 (57.32)	260 (6.30)	187 (412)
	JIS 20K	1464 (57.64)	260 (6.30)	187 (412)
200 (8 in)	PN 40 (EN 1092-1 B1)	1637 (64.45)	320 (12.6)	209 (461)
	CL150 (ASME B16.5)	1650 (64.96)	298.5 (11.75)	204 (450)
	CL300 (ASME B16.5)	1670 (65.75)	330.2 (13.0)	229 (505)
	CL600 (ASME B16.5)	1730 (68.11)	-	-
	JIS10K	1585 (62.4)	290 (11.42)	209 (461)
	JIS 16K	1615 (63.58)	305 (12.01)	210 (463)
	JIS 20K	1623 (63.90)	305 (12.01)	210 (463)

Tolerance for dimension L: +0 / -3 mm (+0 / -0.018 in)

Devices DN 15 to 150 in NAMUR standard installation lengths (order option S5, S7)

Sensor with wetted parts made from stainless steel.

All dimensions and weights are specified in mm (in) or kg (lb).

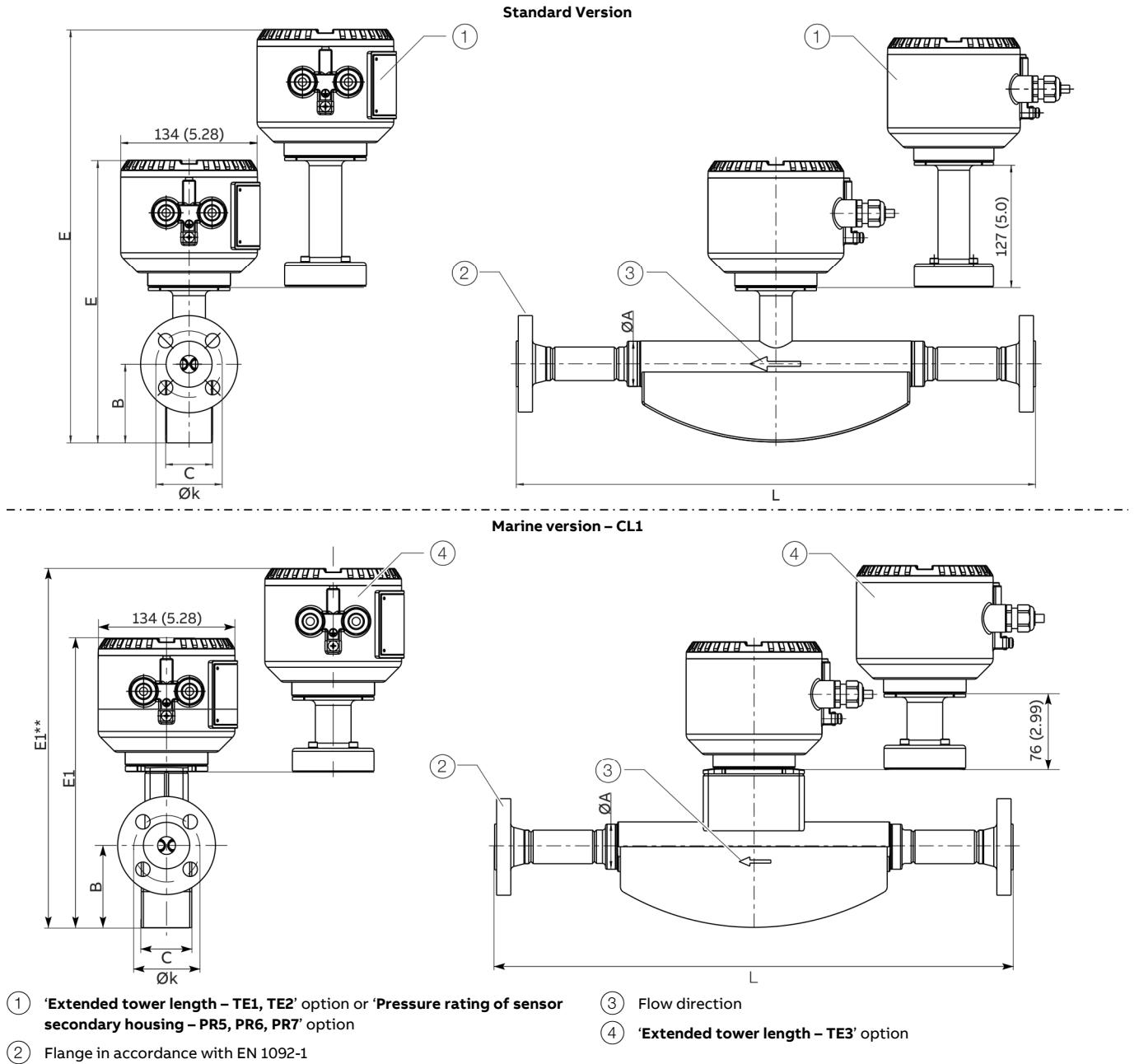

* Standard version: devices with 'Extended tower length – TE1, TE2' option or 'Pressure rating of sensor secondary housing' option

** Marine version – CL1: devices with 'Extended tower length – TE3' option

Figure 10: Remote mount design

... Flowmeter sensor

Devices DN 15 to 150 in NAMUR standard installation lengths									
Meter tube	Process connection	L	Ø k	Ø A	B	C	E	E1 Approximate weight	
EN 1092-1 B1									
DN 15 (½ in)	DN 15 (½ in) / PN 40	510 (20.08)	60 (2.4)	44.5 (1.8)	77 (3.0)	46 (1.8)	283 (11.1)	283 (11.1)	13.5 (29.8)
							410* (16.1*)	357** (14.1**)	
DN 25 (1 in)	DN 25 (1 in) / PN 40	600 (23.62)	75 (3.0)	69.5 (2.74)	103 (4.06)	62 (2.44)	324 (12.8)	324 (12.8)	15 (33.1)
							451* (17.8*)	398** (15.7**)	
DN 50 (1 in)	DN 50 (1 in) / PN 40	715 (28.15)	125 (4.92)	99 (3.9)	125 (4.92)	80 (3.15)	354 (13.9)	354 (13.9)	31 (68.3)
							481* (18.94*)	428** (16.9**)	
DN 80 (3 in)	DN 80 (3 in) / PN 40	915 (36.02)	160 (6.30)	155 (6.1)	183 (7.2)	123 (4.84)	445 (17.52)	–	74 (163)
							572* (22.52*)		
DN 100 (4 in)	DN 100 (4 in) / PN 16	1400 (55.12)	180 (7.09)	195 (7.68)	261 (10.28)	168 (6.61)	541 (21.3)	–	123 (271)
							668* (26.3*)		
DN 150 (6 in)	DN 150 (6 in) / PN 16	1700 (66.93)	240 (9.45)	260 (10.24)	320 (12.6)	205 (8.07)	630 (24.8)	–	178 (392)
							757* (29.8*)		

* Standard version: devices with 'Extended tower length – TE1, TE2' option or 'Pressure rating of sensor secondary housing' option

** Marine version – CL1: devices with 'Extended tower length – TE3' option

Tolerance for dimension L: +0 / –3 mm (+0 / –0.018 in)

Devices with meter tube nominal diameter DN 15 to 80 und connections in accordance with SMS 1145, DIN 11851, DIN 32676, DIN ISO 228, ASME BPE and ASME B 1.20.1

Sensor with wetted parts made from stainless steel.

All dimensions and weights are specified in mm (in) or kg (lb).

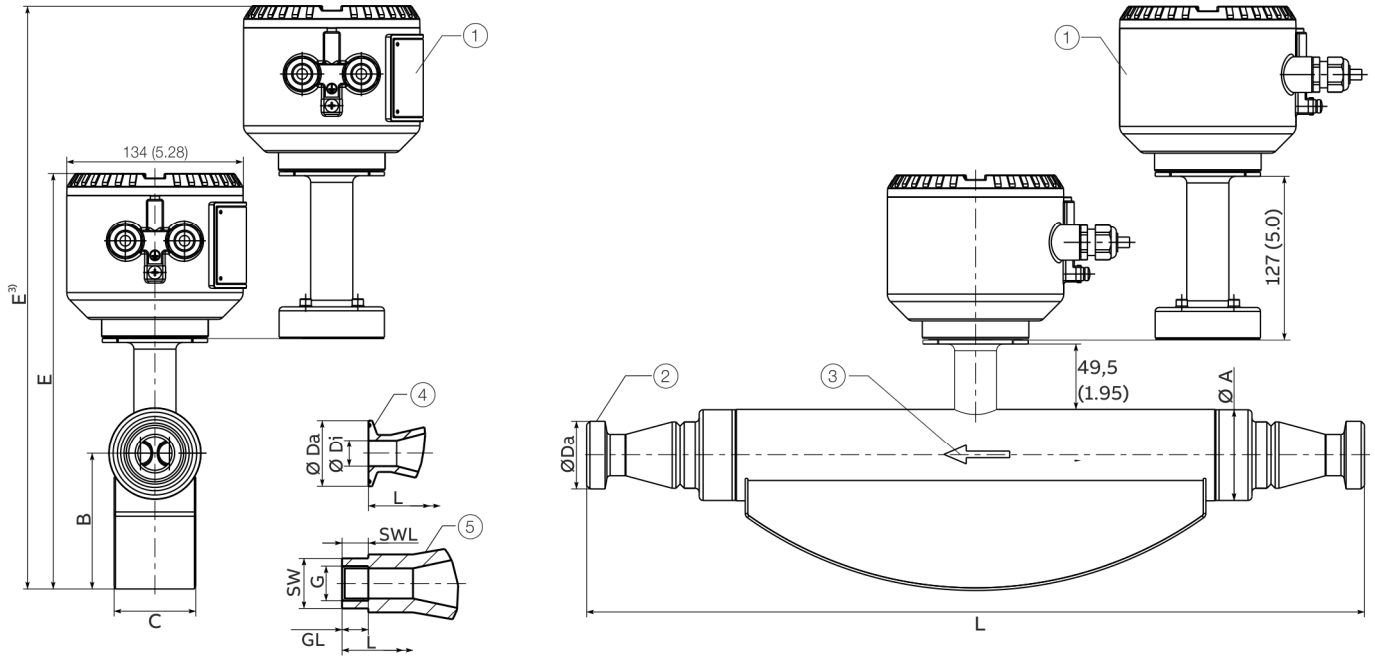

- ① 'Extended tower length – TE1, TE2' option or 'Pressure rating of sensor secondary housing – PR5, PR6, PR7' option
- ② Threaded spuds in accordance with DIN 11851 and SMS 1145
- ③ Flow direction
- ④ Clamping connection in accordance with DIN 32676 and ASME BPE
- ⑤ Female thread connection in accordance with DIN ISO 228 and ASME B 1.20.1

Figure 11: Remote mount design

Process connection in accordance with SMS 1145 meter tube nominal diameter DN 25 to 80 (1 to 3 in)											
Meter tube DN	Process connection		L	Ø DA	Ø Di	Ø A	B	C	E	Approximate weight	
	DN	PN								Aluminum*	Stainless steel**
25 (1 in)	25 (1 in)	6	590 (23.2)	RD 40x½ in	22.6 (0.89)	69.5	103	62	317 / 444***	11 / 12***	14 / 15***
	40 (1 ½ in)			RD 60x½ in	38 (1.50)	(2.74)	(4.06)	(2.44)	(12.48 / 17.48***)	(24 / 27***)	(31 / 33***)
50 (2 in)	40 (1 ½ in)	6	763 (30.0)	RD 60x½ in	35.5 (1.40)	99	125	80	354 / 481***	27 / 28***	30 / 31***
	50 (2 in)		740 (29.1)	RD 70x½ in	48.5 (1.91)	(3.46)	(4.92)	(3.15)	(13.94 / 18.94***)	(60 / 62***)	(66 / 68***)
	65 (2 ½ in)			RD 85x½ in	60.5 (2.38)						
80 (3 in)	65 (2 ½ in)		990 (39.0)	RD 85x½ in	60.5 (2.38)	155	183	123	445 / 572***	68 / 69***	71 / 72***
	80 (3 in)		940 (37.0)	RD 98x¼ in	72.6 (2.86)	(6.10)	(7.20)	(4.84)	(17.52 / 22.52***)	(150 / 152***)	(157 / 159***)

* Devices with terminal boxes made from aluminum.

** Devices with terminal boxes made from stainless steel.

*** Devices with 'Extended tower length' option or 'Pressure rating of sensor secondary housing' option.

... Flowmeter sensor

Process connection in accordance with DIN 11851 meter tube nominal diameter DN 15 to 80 (½ to 3 in.)

Meter tube DN	Process connection		L	Ø DA	Ø Di	Ø A	B	C	E	Approximate weight							
	DN	PN								Aluminum*	Stainless steel**						
15 (½ in)	10 (¾ in)	40	413 (16.3)	RD 28x⅛ in	10 (0.39)	44.5	77 (3.03)	46 (1.81)	278 / 405***	9 / 10***	12 / 13***						
	15 (½ in)			RD 34x⅛ in								16 (0.63)	(1.75)	(10.94 / 15.94***)	(20 / 22***)	(27 / 29***)	
	20 (¾ in)			RD 44x⅛ in								20 (0.79)					
25 (1 in)	20 (¾ in)	590 (23.2)	RD 44x⅛ in	20 (0.79)	69.5	103	62	317 / 444***	11 / 12***	14 / 15***							
	25 (1 in)			RD 52x⅛ in							26 (1.02)	(2.74)	(4.06)	(2.44)	(12.48 / 17.48***)	(24 / 27***)	(31 / 33***)
	40 (1 ½ in)			RD 65x⅛ in							38 (1.5)						
50 (2 in)	40 (1 ½ in)	763 (30.0)	RD 65x⅛ in	38 (1.5)	99 (3.46)	125	80	354 / 481***	27 / 28***	30 / 31***							
	50 (2 in)			RD 78x⅛ in							50 (1.97)	(4.92)	(3.15)	(13.94 / 18.94***)	(60 / 62***)	(66 / 68***)	
	65 (2 ½ in)			RD 95x⅛ in							66 (2.6)						
80 (3 in)	65 (2 ½ in)	990 (39.0)	RD 95x⅛ in	66 (2.6)	155	183	123	445 / 572***	68 / 69***	71 / 72***							
	80 (3 in)			RD 110x¼ in							81 (3.19)	(6.10)	(7.20)	(4.84)	(17.52 / 22.52***)	(150 / 152***)	(157 / 159***)
	100 (4 in)			RD 130x¼ in							100 (3.94)						

Process connection in accordance with DIN 32676 meter tube nominal diameter DN 15 to 80 (½ to 3 in.)

Meter tube DN	Process connection		L	Ø DA	Ø Di	Ø A	B	C	E	Approximate weight								
	DN	PN								Aluminum*	Stainless steel**							
15 (½ in)	10 (¾ in)	40	413 (16.3)	34 (1.34)	10 (0.39)	44.5	77 (3.03)	46 (1.81)	278 / 405***	9 / 10***	12 / 13***							
	15 (½ in)			16 (0.63)								(1.75)	(10.94 / 15.94***)	(20 / 22***)	(27 / 29***)			
	20 (¾ in)			20 (0.79)														
25 (1 in)	20 (¾ in)	590 (23.2)	RD 44x⅛ in	20 (0.79)	69.5	103	62	317 / 444***	11 / 12***	14 / 15***								
	25 (1 in)			50.5 (1.99)							26 (1.02)	(2.74)	(4.06)	(2.44)	(12.48 / 17.48***)	(24 / 27***)	(31 / 33***)	
	40 (1 ½ in)			38 (1.5)														
50 (2 in)	40 (1 ½ in)	763 (30.0)	RD 65x⅛ in	38 (1.5)	99 (3.46)	125	80	354 / 481***	27 / 28***	30 / 31***								
	50 (2 in)			25							740 (29.1)	64 (2.52)	50 (1.97)	(4.92)	(3.15)	(13.94 / 18.94***)	(60 / 62***)	(66 / 68***)
	65 (2 ½ in)			91 (3.58)							66 (2.6)							
80 (3 in)	65 (2 ½ in)	10	950 (37.4)	66 (2.6)	155	183	123	445 / 572***	68 / 69***	71 / 72***								
	80 (3 in)			910 (35.83)							106 (4.17)	81 (3.19)	(6.10)	(7.20)	(4.84)	(17.52 / 22.52***)	(150 / 152***)	(157 / 159***)
	100 (4 in)			119 (4.69)							100 (3.94)							

* Devices with terminal boxes made from aluminum.

** Devices with terminal boxes made from stainless steel.

*** Devices with 'Extended tower length' option or 'Pressure rating of sensor secondary housing' option.

Tolerance for dimension L: +0 / -3 mm (+0 / -0.018 in)

Dimensions for sensors featuring meter tubes with nominal diameter DN 15 to 80 (½ to 3 in.) and process connection in accordance with ASME BPE											
Meter tube DN	Process connection		L	Ø DA	Ø Di	Ø A	B	C	E	Approximate weight	
	DN	PN								Aluminum ¹	Stainless steel ²
15 (½ in)	¾ in Type A	10	–	–	–	44.5	77 (3.03)	46 (1.81)	278 / 405 ³	9 / 10 ³	12 / 13 ³
	½ in Type A		433 (17.05)	25 (0.98)	9.4 (0.37)	(1.75)			(10.94 / 15.94 ³)	(20 / 22 ³)	(27 / 29 ³)
	¾ in Type A		–	–	–						
25 (1 in)	¾ in Type A		–	–	–	69.5	103	62	317 / 444 ³	11 / 12 ³	14 / 15 ³
	1 in Type B		590 (23.23)	50.4 (1.98)	22.1 (0.87)	(2.74)	(4.06)	(2.44)	(12.48 / 17.48 ³)	(24 / 27 ³)	(31 / 33 ³)
	1 ½ in Type B		590 (23.23)	50.4 (1.98)	34.8 (1.37)						
50 (2 in)	1 ½ in Type B		–	–	–	99 (3.46)	125	80	354 / 481 ³	27 / 28 ³	30 / 31 ³
	2 in Type B		740 (29.13)	63.9 (2.52)	47.5 (1.87)		(4.92)	(3.15)	(13.94 / 18.94 ³)	(60 / 62 ³)	(66 / 68 ³)
	2 ½ in Type B		–	–	–						
80 (3 in)	2 ½ in Type B		950 (37.40)	77.4 (3.05)	60.2 (2.37)	155	183	183	445 / 572 ³	68 / 69 ³	71 / 72 ³
	3 in Type B		910 (35.83)	90.9 (3.19)	72.9 (2.87)	(6.10)	(7.20)	(7.20)	(17.52 / 22.52 ³)	(150 / 152 ³)	(157 / 159 ³)
	4 in Type B		910 (35.83)	118.9 (4.68)	97.4 (3.83)						

Process connection in accordance with DIN ISO 228 and ASME B 1.20.1, meter tube nominal diameter DN 15 to 80 (½ to 3 in)												
Meter tube DN	Process connection		L	GL ⁴	WS ⁵	SWL ⁵	Ø A	B	C	E	Approximate weight	
	DN / G	PN									Aluminum ¹	Stainless steel ²
15 (½ in)	8 (¼ in) / G ¼ in	100	450	10 (0.39)	19	10 (0.39)	44.5	77 (3.03)	46 (1.81)	278 / 405 ³	9 / 10 ³	12 / 13 ³
			(17.72)				(1.75)			(10.94 / 15.94 ³)	(20 / 22 ³)	(27 / 29 ³)
	15 (½ in) / G ½ in		13.5 (0.53)	27	15 (0.59)							
			25 (1 in) / G 1 in	490	17 (0.67)	50	20 (0.79)					
			(19.29)									
	15 (½ in) / ½ in NPT		450	15.6 (0.61)	27	15 (0.59)						
			(17.72)									

¹ Devices with terminal boxes made from aluminum.

² Devices with terminal boxes made from stainless steel.

³ Devices with 'Extended tower length' option or 'Pressure rating of sensor secondary housing' option.

⁴ Dimension GL: Provide thread length of female thread.

⁵ Dimension SW: Provide width across flats in mm, Dimension SWL: Provide length of wrench flats in mm.

Tolerance for dimension L: +0 / –3 mm (+0 / –0.018 in)

... Flowmeter sensor

Sensor with wetted parts made from C4 or C22 nickel alloy

For devices with wetted parts made from C4 or C22 nickel alloy, the installation length (L) is different from previous tables. All other dimensions and the weight are unchanged.

Dimensions in mm (in).

Dimensions for sensors with process connection in accordance with EN 1092-1 and ASME B16.5 (ANSI)									
Meter tube nominal diameter	Process connection	L		L		L		L	
		EN 1092-1 B1	EN 1092-1 B1	EN 1092-1 B2	EN 1092-1 B2	ASME	ASME	ASME	JIS 10K
		PN 16	PN 40	PN 63	PN 100	CL150	CL300	CL600	
DN 15 (½ in)	DN 10 (¼ in)	–	449 (17.7)	449 (17.7)	449 (17.7)	–	–	–	449 (17.7)
	DN 15 (½ in)	–	442 (17.4)	442 (17.4)	442 (17.4)	442 (17.4)	442 (17.4)	442 (17.4)	442 (17.4)
	DN 20 (¾ in)	–	428 (16.9)	428 (16.9)	428 (16.9)	428 (16.9)	428 (16.9)	428 (16.9)	428 (16.9)
DN 25 (1 in)	DN 20 (¾ in)	–	646 (25.4)	646 (25.4)	646 (25.4)	646 (25.4)	646 (25.4)	646 (25.4)	646 (25.4)
	DN 25 (1 in)	–	614 (24.2)	614 (24.2)	614 (24.2)	614 (24.2)	614 (24.2)	614 (24.2)	614 (24.2)
	DN 40 (1½ in)	–	576 (22.7)	576 (22.7)	576 (22.7)	576 (22.7)	576 (22.7)	576 (22.7)	576 (22.7)
DN 50 (2 in)	DN 40 (1½ in)	–	814 (32.0)	814 (32.0)	814 (32.0)	814 (32.0)	814 (32.0)	814 (32.0)	814 (32.0)
	DN 50 (2 in)	–	764 (30.1)	764 (30.1)	764 (30.1)	764 (30.1)	764 (30.1)	764 (30.1)	764 (30.1)
	DN 65 (2½ in)	–	819 (32.2)	819 (32.2)	819 (32.2)	792 (31.2)	792 (31.2)	792 (31.2)	819 (32.2)
DN 80 (3 in)	DN 65 (2½ in)	–	1021 (40.2)	1021 (40.2)	1021 (40.2)	1021 (40.2)	1021 (40.2)	1021 (40.2)	1021 (40.2)
	DN 80 (3 in)	–	971 (38.2)	–	971 (38.2)	971 (38.2)	971 (38.2)	971 (38.2)	971 (38.2)
	DN 100 (4 in)	971 (38.2)	971 (38.2)	971 (38.2)	971 (38.2)	971 (38.2)	971 (38.2)	971 (38.2)	971 (38.2)
DN 100 (4 in)	DN 80 (3 in)	1357 (53.4)	1357 (53.4)	1357 (53.4)	1357 (53.4)	1357 (53.4)	1357 (53.4)	1357 (53.4)	1357 (53.4)
	DN 100 (4 in)	1280 (50.4)	1280 (50.4)	1280 (50.4)	1280 (50.4)	1280 (50.4)	1280 (50.4)	1280 (50.4)	1280 (50.4)
	DN 150 (6 in)	1261 (49.6)	1261 (49.6)	1261 (49.6)	1261 (49.6)	1261 (49.6)	1261 (49.6)	1261 (49.6)	1261 (49.6)
DN 150 (6 in)	DN 100 (4 in)	1592 (62.7)	1592 (62.7)	1632 (64.3)	1632 (64.3)	1592 (62.7)	1632 (64.3)	1632 (64.3)	1592 (62.7)
	DN 150 (6 in)	1502 (59.1)	1502 (59.1)	1542 (60.7)	1542 (60.7)	1502 (59.1)	1542 (60.7)	1542 (60.7)	1502 (59.1)

L dimension tolerance:

- Meter tube nominal diameter DN 15 to 50 (½ to 2 in): +0 / –3 mm (+0 / –0.018 in)
- Meter tube nominal diameter DN 80 (3 in): +0 / –5 mm (+0 / –0.2 in)
- Meter tube nominal diameter DN 100 to 150 (4 to 6 in): +0 / –8 mm (+0 / –0.31 in)

Ordering information

Note

For additional information on dependencies and restrictions, and for help on product selection, please refer to the Online Product Selection Assistant (PSA) at www.abb.us/flow-selector.

CoriolisMaster FCB430, FCB450

Main ordering information												
CoriolisMaster FCB430 Coriolis Mass Flowmeter	FCB430	XX	XX	XXXXX	XX	XX	X	X	XX	XX	X	
CoriolisMaster FCB450 Coriolis Mass Flowmeter	FCB450	XX	XX	XXXXX	XX	XX	X	X	XX	XX	X	
Explosion Protection Certification												
General Purpose		Y0										
ATEX / IECEx (Zone 2 / 22)		A2										
ATEX / IECEx (Zone 1 / 21)		A1										
cFMus version Class 1 Div. 2 (Zone 2 / 21)		F2										
cFMus version Class 1 Div. 1 (Zone 1 / 21)		F1										
NEPSI (Zone 2 / 22)		S2										
NEPSI (Zone 1 / 21)		S1										
Connection Design / Connection Box Material / Cable Glands												
Integral, defined by Transmitter housing		Y0										
Remote / Aluminium / 1 x M20 x 1.5		U1										
Remote / Aluminium / 1 x NPT ½ in		U2										
Remote / Stainless Steel / 1 x M20 x 1.5		A1										
Remote / Stainless Steel / 1 x NPT ½ in		A2										
Meter Size / Connection Size												
DN 15 (½ in) / DN 10 (¾ in)				015E1								
DN 15 (½ in) / DN 15 (½ in)				015R0								
DN 15 (½ in) / DN 20 (¾ in)				015R1								
DN 25 (1 in) / DN 20 (¾ in)				025E1								
DN 25 (1 in) / DN 25 (1 in)				025R0								
DN 25 (1 in) / DN 40 (1½ in)				025R2								
DN 50 (2 in) / DN 40 (1½ in)				050E1								
DN 50 (2 in) / DN 50 (2 in)				050R0								
DN 50 (2 in) / DN 65 (2½ in)				050R1								
DN 80 (3 in) / DN 65 (2½ in)				080E1								
DN 80 (3 in) / DN 80 (3 in)				080R0								
DN 80 (3 in) / DN 100 (4 in)				080R1								
DN 100 (4 in) / DN 80 (3 in)				100E1								
DN 100 (4 in) / DN 100 (4 in)				100R0								
DN 100 (4 in) / DN 150 (6 in)				100R2								
DN 150 (6 in) / DN 100 (4 in)				150E2								
DN 150 (6 in) / DN 150 (6 in)				150R0								
DN 150 (6 in) / DN 200 (8 in)				150R2								

Continued see next page

... Flowmeter sensor

Main ordering information							
CoriolisMaster FCB430 Coriolis Mass Flowmeter	XX	XX	X	X	XX	XX	X
CoriolisMaster FCB450 Coriolis Mass Flowmeter	XX	XX	X	X	XX	XX	X
Process Connection Type							
Flanges DIN PN 16	D2						
Flanges DIN PN 40	D4						
Flanges DIN PN 63	D5						
Flanges DIN PN 100	D6						
Flanges EN 1092-1 PN 40, NAMUR length (DN 15, DN 25, DN 50)	S5						
Flanges with groove PN40 EN1092-10-D	S6						
Flanges EN 1092-1 PN 16, NAMUR length (DN 100, DN 150)	S7						
Flanges ANSI / ASME B16.5 Class 150	A1						
Flanges ANSI / ASME B16.5 Class 300	A3						
Flanges ANSI / ASME B16.5 Class 600	A6						
Flanges ANSI / ASME B16.5 Class 900 (p-t rating CI 600)	A7						
Flanges ANSI / ASME B16.5 Class 1500 (p-t rating CI 600)	A8						
Flanges JIS 10K	J1						
Flanges JIS 20K	J3						
Sanitary Couplings SMS1145 for pipes acc. DIN11866 Series A	K1						
Tri-Clamp acc. DIN 32676	T1						
Tri-Clamp acc. BPE	T3						
Food industry fittings acc. DIN 11851	F1						
Female NPT thread	N5						
Female G thread	M5						
Others	Z9						
Material of Wetted Parts							
Stainless steel		A1					
Ni-Alloy		C1*					
Flow Calibration							
Flow forward ± 0.40 % of flow rate, Gas 1 % of flow rate							A**
Flow forward ± 0.25 % of flow rate, Gas 1 % of flow rate							B**
Flow forward ± 0.2 % of flow rate, Gas 1 % of flow rate							E**
Forward ±0.15% of flow rate, Gas 0.5 % of flow rate							C***
Forward ±0.10% of flow rate, Gas 0.5 % of flow rate							D***
Flow forward / reverse ± 0.40 % of flow rate, Gas 1 % of flow rate							J**
Flow forward / reverse ± 0.25 % of flow rate, Gas 1 % of flow rate							K**
Flow forward / reverse ± 0.20 % of flow rate, Gas 1 % of flow rate							N**
Flow forward / reverse ± 0.15 % of flow rate, Gas 0.5 % of flow rate							L***
Flow forward / reverse ± 0.10 % of flow rate, Gas 0.5 % of flow rate							M***
Others							Z

* If the sensor wetted parts are Ni-Alloy based, parts of the sensor housing are Ni-Alloy based too.

** Only with CoriolisMaster FCB430

*** Only with CoriolisMaster FCB450

Continued see next page

Main ordering information				
CoriolisMaster FCB430 Coriolis Mass Flowmeter	X	XX	XX	X
CoriolisMaster FCB450 Coriolis Mass Flowmeter	X	XX	XX	X
Density Calibration				
Density 10 g/l	1 ¹			
Density 2 g/l	3 ²			
Density 1 g/l	4 ²			
Density 0.5 g/l	5 ²			
Others	9			
Connection Design / Transmitter Housing Type / Transmitter Housing Material / Cable Glands				
Integral / Dual compartment / Aluminum / 3 × M20 × 1.5			D1	
Integral / Dual compartment / Aluminum / 3 × NPT ½ in			D2	
Integral / Dual compartment / Aluminum / 3 × NPT ½ in (Exd, XP)			D5	
Integral / Dual compartment / Aluminum / 3 × M20 × 1.5 (Exd, XP)			D6	
Integral / Single-compartment / Aluminum / 3 × M20 × 1,5			S1	
Integral / Single-compartment / Aluminum / 3 × NPT ½ in			S2	
Remote / Not specified			Y0	
Others			Z9	
Outputs				
Current output 1 (active or passive), digital output 1 & 2 (passive), HART, PROFIBUS DP			D1	
Current output 1 (active or passive), digital output 1 & 2 (passive), HART, MODBUS			M1 ³	
Current output 1 (active or passive), digital output 1 & 2 (passive), HART			G0	
Current output 1 (active or passive), digital output 1 & 2 (passive), HART 1 Port Ethernet			E2 ⁴	
Current output 1 (active or passive), digital output 1 & 2 (passive), HART 2 Port Ethernet			E3 ⁴	
Current output 1 (active or passive), digital output 1 & 2 (passive), HART, 1 PortEthernet + POE			E4 ⁴	
Current output 1 (active or passive), digital output 1 & 2 (passive), 24 V DC transmitter loop power supply, HART			G1	
Current output 1 (active or passive), digital output 1 & 2 (passive), current output 2 (passive), HART			G2	
Current output 1 (active or passive), digital output 1 & 2 (passive), current output 2 (passive), current output 3 (passive), HART			G3	
Current output 1 (active or passive), digital output 1 & 2 (passive), current output 2 (passive), 24 V DC transmitter loop power supply, HART			G4	
Without			Y0	
Power Supply				
100 to 230 V AC				A
11 to 30 V DC				C
Without				Y

- 1 Only with CoriolisMaster FCB430
- 2 Only with CoriolisMaster FCB450
- 3 The M1 version is identical to the M5 version as it may be named elsewhere
- 4 Available with single compartment housing only, Non-Ex or Zone 2, Div. 2 only

Continued see next page

... Flowmeter sensor

Additional ordering information

Additional ordering information							
CoriolisMaster FCB430 Coriolis Mass Flowmeter	XX	XXX	XXX	XXX	XXX	XX	XX
CoriolisMaster FCB450 Coriolis Mass Flowmeter	XX	XXX	XXX	XXX	XXX	XX	XX
Certificates							
Test report 2.2 acc. EN 10204 confirmation of material	C1						
Material monitoring with inspection certificate 3.1 acc. EN 10204	C2						
Material monitoring with inspection certificate 3.2 acc. EN 10204	C3						
Material monitoring NACE MR 01-75 with inspection certificate 3.1 acc. EN 10204	CN						
Declaration of compliance with the order 2.1 acc. EN 10204	C4						
Inspection certificate 3.1 acc. EN 10204 for visual, dimensional and functional test	C6						
Inspection certificate 3.1 acc. EN 10204 for positive material identification PMI (confirmation only)	CA						
Pressure test acc. AD2000	CB						
Test package (pressure test, non-destructive test, welder & welding procedure certificate)	CT						
Inspection certificate 3.1 acc. EN 10204 for NDE of welds	C8						
Certificate of accuracy 2.1 acc. EN 10204	CM						
Inspection certificate 3.1 acc. EN 10204 for positive material identification PMI (inclusive heat analysis)	CR						
Others	CZ						
Ships Register Certifications							
DNVGL						CL1	
Bureau Veritas						CL4	
Custody Transfer Certification							
Custody transfer acc. MID (OIML)						CM1*	
Additional Output 1							
1 × Digital input						DRN	
1 × Digital output						DRG	
1 × Analog output passive (4 to 20 mA)						DRA	
24 V DC transmitter loop power supply						DRT	
MODBUS						DRM	
PROFIBUS DP						DRD	
2 port Ethernet (various protocols)						DR6**	
Additional Output 2							
1 × Digital input						DSN	
1 × Digital output						DSG	
1 × Analog output passive (4 to 20 mA)						DSA	
Modul Power over Ethernet / Modbus (for Single Comp Hsg)						DS8**	
Integrated Digital Display (LCD)							
No Display, with Blind Cover							L0
With capacitive sensorbuttons / Display (TTG) / Glass cover							L2
Functional Safety							
SIL2 certificate							CS

* Only with CoriolisMaster FCB450

** Available with single compartment housing only, Non-Ex or Zone 2, Div. 2 only

Continued see next page

Additional ordering information

CoriolisMaster FCB430 Coriolis Mass Flowmeter	XXX	XX	XX	XXX	XXX
CoriolisMaster FCB450 Coriolis Mass Flowmeter	XXX	XX	XX	XXX	XXX

Device Display Language

German	BM1				
English	BM5				
French	BM4				
Spanish	BM3				
Italien	BM2				
Portuguese	BMA				
Chinese	BM6				

Documentation Language

German		M1			
English		M5			
Language package Western Europe / Scandinavia (Languages: DA, ES, FR, IT, NL, PT, FI, SV)		MW			
Language package Eastern Europe (Languages: EL, CS, ET, LV, LT, HU, HR, PL, SK, SL, RO, BG)		ME			
Others		MZ			

Additional Software Features

Standard + DensiMass concentration measurement				N6*	
Standard + Filling application				N5*	
VeriMass - Meter verification				N7	
CoriolisControl (ECC)				N8	

Pressure Rating of Sensor Secondary Containment

Maximum burst pressure 6 MPa / 60 bar / 870 psi inclusive tower length extension					PR5
Maximum burst pressure 10 MPa / 100 bar / 1450 psi inclusive tower length extension					PR6
Maximum burst pressure 15 MPa / 150 bar / 2175 psi inclusive tower length extension					PR7

Signal Cable Length

Without signal cable					SC0
5 m (approx. 15 ft)					SC1
10 m (approx. 30 ft)					SC2
20 m (approx. 66 ft)					SC4
25 m (approx. 82 ft)					SC5
30 m (approx. 98 ft)					SC6
40 m (approx. 131 ft)					SC8
50 m (approx. 164 ft)					SCA
100 m (approx. 328 ft)					SCE
150 m (approx. 492 ft)					SCG
200 m (approx. 656 ft)					SCJ
Others					SCZ

* Only with CoriolisMaster FCB450

... Flowmeter sensor

Additional ordering information

CoriolisMaster FCB430 Coriolis Mass Flowmeter	XX	XXX	XXX
CoriolisMaster FCB450 Coriolis Mass Flowmeter	XX	XXX	XXX
Device Identification Plate			
Stainless steel plate with TAG no.	T1		
Others	TZ		
Ambient Temperature Range			
-40 to 70 °C (-40 to 158 °F)			TA9
Extended Tower Length			
Tower length extension - meter insulation capability			TE1
Tower length extension - meter insulation capability with double sealing			TE2
Tower length extension -short- insulation capability			TE3

CoriolisMaster FCH430, FCH450

Main ordering information												
CoriolisMaster FCH430 Coriolis Mass Flowmeter	FCH430	XX	XX	XXXXX	XX	XX	X	X	XX	XX	X	
CoriolisMaster FCH450 Coriolis Mass Flowmeter	FCH450	XX	XX	XXXXX	XX	XX	X	X	XX	XX	X	
Explosion Protection Certification												
General Purpose		Y0										
ATEX / IECEx (Zone 2 / 22)		A2										
ATEX / IECEx (Zone 1 / 21)		A1										
cFMus version Class 1 Div. 2 (Zone 2 / 21)		F2										
cFMus version Class 1 Div. 1 (Zone 1 / 21)		F1										
NEPSI (Zone 2 / 22)		S2										
NEPSI (Zone 1 / 21)		S1										
Connection Design / Connection Box Material / Cable Glands												
Integral, defined by Transmitter housing		Y0										
Remote / Aluminium / 1 x M20 x 1.5		U1										
Remote / Aluminium / 1 x NPT ½ in		U2										
Remote / Stainless Steel / 1 x M20 x 1.5		A1										
Remote / Stainless Steel / 1 x NPT ½ in		A2										
Meter Size / Connection Size												
DN 25 (1 in) / DN 20 (¾ in)					025E1							
DN 25 (1 in) / DN 25 (1 in)					025R0							
DN 25 (1 in) / DN 40 (1½ in)					025R2							
DN 50 (2 in) / DN 40 (1½ in)					050E1							
DN 50 (2 in) / DN 50 (2 in)					050R0							
DN 50 (2 in) / DN 65 (2½ in)					050R1							
DN 80 (3 in) / DN 65 (2½ in)					080E1							
DN 80 (3 in) / DN 80 (3 in)					080R0							
DN 80 (3 in) / DN 100 (4 in)					080R1							
Process Connection Type												
Tri-Clamp acc. DIN 32676											T1	
Tri-Clamp acc. BPE											T3	
Food industry fittings acc. DIN 11851											F1	
Others											Z9	

Continued see next page

... Flowmeter sensor

Main ordering information

CoriolisMaster FCH430 Coriolis Mass Flowmeter	XX	X	XX	XX	X
CoriolisMaster FCH450 Coriolis Mass Flowmeter	XX	X	XX	XX	X

Material of Wetted Parts

Stainless steel polished 316L (1.4404 / 1.4435)	H2				
---	----	--	--	--	--

Flow Calibration

Flow forward +/- 0.40 % of flow rate, Gas 1 % of flow rate	A**				
Flow forward +/- 0.25 % of flow rate, Gas 1 % of flow rate	B**				
Flow forward +/- 0.2 % of flow rate, Gas 1 % of flow rate	E**				
Forward +/-0.15% of flow rate, Gas 0.5 % of flow rate	C***				
Forward +/-0.10% of flow rate, Gas 0.5 % of flow rate	D***				
Flow forward / reverse +/- 0.40 % of flow rate, Gas 1 % of flow rate	J**				
Flow forward / reverse +/- 0.25 % of flow rate, Gas 1 % of flow rate	K**				
Flow forward / reverse +/- 0.20 % of flow rate, Gas 1 % of flow rate	N**				
Flow forward / reverse +/- 0.15 % of flow rate, Gas 0.5 % of flow rate	L***				
Flow forward / reverse +/- 0.10 % of flow rate, Gas 0.5 % of flow rate	M***				
Others	Z				

Density Calibration

Density 10 g/l				1*	
Density 2 g/l				3**	
Density 1 g/l				4**	
Density 0.5 g/l				5**	

Others

9

* If the wetted parts of the sensor are made from nickel alloy then parts of the sensor housing are also manufactured from nickel alloy.

** Only with CoriolisMaster FCH430

*** Only with CoriolisMaster FCH450

Continued see next page

Main ordering information			
CoriolisMaster FCH430 Coriolis Mass Flowmeter	XX	XX	X
CoriolisMaster FCH450 Coriolis Mass Flowmeter	XX	XX	X
Connection Design / Transmitter Housing Type / Transmitter Housing Material / Cable Glands			
Integral / Dual compartment / Aluminium / 3 x M20 x 1.5	D1		
Integral / Dual compartment / Aluminium / 3 x NPT 1/2 in	D2		
Integral / Dual compartment / Aluminium / 3 x NPT 1/2 in (Exd, XP)	D5		
Integral / Dual compartment / Aluminium / 3 x M20 x 1.5 (Exd, XP)	D6		
Remote / Not specified	Y0		
Others	Z9		
Outputs			
Current output 1 (active or passive), digital output 1 & 2 (passive), HART, PROFIBUS DP		D1	
Current output 1 (active or passive), digital output 1 & 2 (passive), HART, MODBUS		M1*	
Current output 1 (active or passive), digital output 1 & 2 (passive), HART		G0	
Current output 1 (active or passive), digital output 1 & 2 (passive), HART 1 Port Ethernet		E2**	
Current output 1 (active or passive), digital output 1 & 2 (passive), HART 2 Port Ethernet		E3**	
Current output 1 (active or passive), digital output 1 & 2 (passive), HART, 1 PortEthernet + POE		E4**	
Current output 1 (active or passive), digital output 1 & 2 (passive), 24 V DC transmitter loop power supply, HART		G1	
Current output 1 (active or passive), digital output 1 & 2 (passive), current output 2 (passive), HART		G2	
Current output 1 (active or passive), digital output 1 & 2 (passive), current output 2 (passive), current output 3 (passive), HART		G3	
Current output 1 (active or passive), digital output 1 & 2 (passive), current output 2 (passive), 24 V DC transmitter loop power supply, HART		G4	
Without		Y0	
Power Supply			
100 to 230 V AC			A
11 to 30 V DC			C
Without			Y

* The M1 version is identical to the M5 version as it may be named elsewhere

** Available with single compartment housing only, Non-Ex or Zone 2, Div. 2 only

Continued see next page

... Flowmeter sensor

Additional ordering information

Additional ordering information							
CoriolisMaster FCH430 Coriolis Mass Flowmeter	XX	XXX	XXX	XXX	XX	XXX	XX
CoriolisMaster FCH450 Coriolis Mass Flowmeter	XX	XXX	XXX	XXX	XX	XXX	XX
Certificates							
Test report 2.2 acc. EN 10204	C1						
Material monitoring with inspection certificate 3.1 acc. EN 10204	C2						
Material monitoring NACE MR 01-75 with inspection certificate 3.1 acc. EN 10204	CN						
Declaration of compliance with the order 2.1 acc. EN 10204	C4						
Inspection certificate 3.1 acc. EN 10204 for visual, dimensional and functional test	C6						
Inspection certificate 3.1 acc. EN 10204 for positive material identification PMI (confirmation only)	CA						
Pressure test acc. AD2000	CB						
Test package (pressure test, non-destructive test, welder & welding procedure certificate)	CT						
Certificate of compliance for calibration 2.1 acc. EN 10204	CM						
Inspection certificate 3.1 acc. EN 10204 for positive material identification PMI (inclusive heat analysis)	CR						
Others	CZ						
Custody Transfer Certification							
Custody transfer acc. MID (OIML)						CM1*	
Additional Output 1							
1 × Digital input						DRN	
1 × Digital output						DRG	
1 × Analog output passive (4 to 20 mA)						DRA	
24 V DC transmitter loop power supply						DRT	
MODBUS						DRM	
PROFIBUS DP						DRD	
2 port Ethernet (various protocols)						DR6***	
Additional Output 2							
1 × Digital input						DSN	
1 × Digital output						DSG	
1 × Analog output passive (4 to 20 mA)						DSA	
Modul Power over Ethernet / Modbus (for Single Comp Hsg)						DS8***	
Integrated Digital Display (LCD)							
No Display, with Blind Cover							L0
With capacitive sensorbuttons / Display (TTG) / Glass cover							L2
Hygienic Approval							
EHEDG							CWL**
Functional Safety							
SIL2 certificate							CS

* Only with CoriolisMaster FCH450

** EHEDG (optional), FDA conform

*** Available with single compartment housing only, Non-Ex or Zone 2, Div. 2 only

Continued see next page

Additional ordering information				
CoriolisMaster FCH430 Coriolis Mass Flowmeter	XXX	XX	XX	XXX
CoriolisMaster FCH450 Coriolis Mass Flowmeter	XXX	XX	XX	XXX
Device Display Language				
German	BM1			
English	BM5			
French	BM4			
Spanish	BM3			
Italien	BM2			
Portuguese	BMA			
Chinese	BM6			
Documentation Language				
German		M1		
English		M5		
Language package Western Europe / Scandinavia (Languages: DA, ES, FR, IT, NL, PT, FI, SV)		MW		
Language package Eastern Europe (Languages: EL, CS, ET, LV, LT, HU, HR, PL, SK, SL, RO, BG)		ME		
Others		MZ		
Additional Software Features				
Standard + DensiMass concentration measurement			N6*	
Standard + Filling application			N5*	
VeriMass - Meter verification			N7	
CoriolisControl (ECC)			N8	
Signal Cable Length				
Without signal cable				SC0
5 m (ca. 15 ft)				SC1
10 m (ca. 30 ft)				SC2
20 m (ca. 66 ft)				SC4
25 m (ca. 82 ft)				SC5
30 m (ca. 98 ft)				SC6
40 m (ca. 131 ft)				SC8
50 m (ca. 164 ft)				SCA
100 m (ca. 328 ft)				SCE
150 m (ca. 492 ft)				SCG
200 m (ca. 656 ft)				SCJ
Others				SCZ

* Only with CoriolisMaster FCH450

Continued see next page

... Flowmeter sensor

Additional ordering information

CoriolisMaster FCH430 Coriolis Mass Flowmeter

XX

XXX

XXX

CoriolisMaster FCH450 Coriolis Mass Flowmeter

XX

XXX

XXX

Device Identification Plate

Stainless steel plate with TAG no.

T1

Others

TZ

Ambient Temperature Range

-40 to 70 °C (-40 to 158 °F)

TA9

Extended Tower Length

Tower length extension - meter insulation capability

TE1

Tower length extension - meter insulation capability with double sealing

TE2

Transmitter

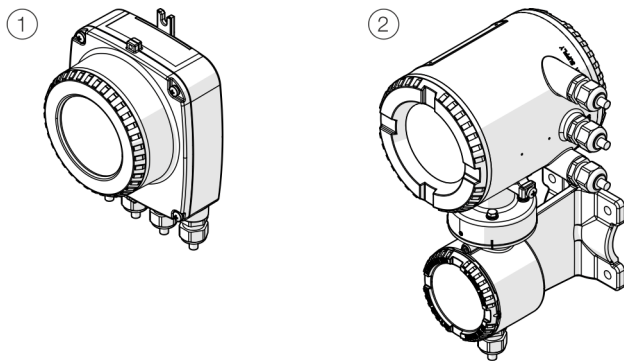

① Single-compartment housing ② Dual-compartment housing

Figure 20: Transmitter FCT4xx in field mount housing (remote mount design)

Features

- 4 to 20 mA current / HART 7.1 output.
- In the event of an alarm, current output can be adjusted to 21 to 23 mA (NAMUR NE43).
- Measuring range: can be adjusted between 0.1 to $1 \times Q_{\max} \text{ DN}$.
- Programmable digital output. Can be configured as a frequency, pulse or binary output.
- Two slots for optional plug-in cards for retrofitting additional current / digital outputs or a digital input.
- Parameterization by means of HART communication.
- Response time $\geq 1 \text{ s}$, as step function 0 to 99 % (corresponds to 5τ)
- Damping: can be adjusted 0.2 to 100 s (1τ).
- Low flow cut-off: 0 to 5 % for current and pulse output.
- Measuring medium parameters can be changed at any time (pressure and temperature influence, density, units, etc.).
- Simulation of current and binary output (manual process execution).

LCD indicator (option)

- Indicator for all measured values of CoriolisMaster (for example mass flow, volume flow rate, density, temperature and many others).
- Application-specific visualizations which the user can select. Four operator pages can be configured to display multiple values in parallel.
- Plain text fault diagnostics
- Menu-guided parameterization with four buttons.
- Easy Set-up function for fast commissioning.
- Operation through the front glass via capacitive buttons.

Diagnostic functions (option)

- VeriMass erosion monitor
- Monitoring function for current output 31 / 32 (analysis and read back of the output value).

For detailed information on optional diagnostic functions, consult the associated operating instruction OI/FCB400/FCH400.

... Transmitter

Optional plug-in cards

The transmitter has two slots (OC1, OC2) into which plug-in cards can be inserted to provide additional inputs and outputs.

The slots are located on the transmitter motherboard and can be accessed after removing the front housing cover.

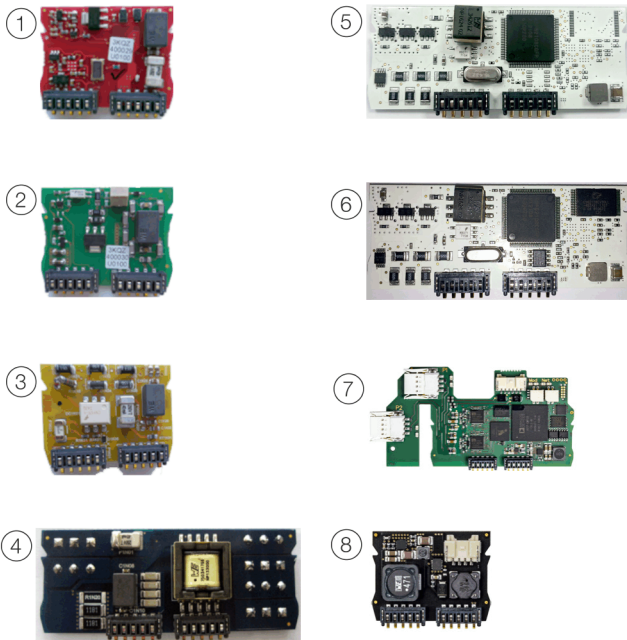

Figure 21: Plug-in cards

Plug-in card	Quantity
① Current output, 4 to 20 mA passive (red) Order no.: 3KQZ400029U0100	2
② Passive digital output (green) Order no.: 3KQZ400030U0100	1
③ Passive digital input (yellow) Order no.: 3KQZ400032U0100	1
④ 24 V DC voltage supply (blue) Order no.: 3KQZ400031U0100	1
⑤ Modbus RTU® RS485 (white) Order no.: 3KQZ400028U0100	1
⑥ PROFIBUS DP® (white) Order no.: 3KQZ400027U0100	1
⑦ Ethernet (various protocols) Order no.: 3KQZ400037U0100	1
⑧ Power-over-Ethernet (POE) Order no.: 3KQZ400039U0100	1

* The 'Number' column indicates the maximum number of plug-in cards of the same type that can be used.

Note

For an overview of the possible plug-in card combinations, refer to **Possible plug-in card combinations** on page 81.

IP rating

In accordance with EN60529: IP 65 / IP 67, NEMA 4X

Vibration

In accordance with EN 60068-2-6

- In the 10 to 58 Hz range, maximum deflection* 0.15 mm (0.006 in.)
 - In the range of 58 to 150 Hz, maximum acceleration 1 g*
- * Single peak load: 2 g

Approved relative humidity

In accordance with EN 60068-2-30

Temperature data

	Standard	Optional
Ambient temperature	-20 to 70 °C (-4 to 158 °F)	-40 to 70 °C (-40 to 158 °F)
Storage temperature	-20 to 70 °C (-4 to 158 °F)	—

Note

When operating below -20 °C (-4 °F), the LCD display can no longer be read and the electronics should be operated with as few vibrations as possible.

Full functionality is assured at temperatures above -20 °C (-4 °F).

Housing design

Integral mount design

Housing	Cast aluminum, painted
Paint	≥ 80 µm thick, RAL 9002 (gray white)
Cable gland	Polyamide, M20 x 1.5 or ½ in. NPT Stainless steel*, M20 x 1.5 or ½ in. NPT

Remote mount design

Housing	Cast aluminum, painted
Paint	≥ 80 µm thick, mid-section RAL 7012 (basalt gray), front cover / rear cover RAL 9002 (gray white)
Cable gland	Polyamide, M20 x 1.5 or ½ in. NPT Stainless steel*, M20 x 1.5 or ½ in. NPT
Weight	4.5 kg (9.92 lb)

* in the case of explosion-proof design for -40 °C (-40 °F) ambient temperature)

Signal cables

The signal cable used for the connection of the transmitter and sensor must fulfill at least the following technical specifications.

Cable specification	
Impedance	100 to 120 Ω
Withstand voltage	120 V
Outer diameter	6 to 12 mm (0.24 to 0.47 in)
Cable design	Two wire pairs as a star-quad cable
Conductor cross-section	Length-dependent
Shield	Copper braid with approximately 85 % coverage
Temperature range	Application-dependent, for use in potentially explosive atmospheres, observe the information in Temperature resistance for the connecting cable on page 90!

Maximum signal cable length	
0.25 mm ² (AWG 24)	50 m (164 ft)
0.34 mm ² (AWG 22)	100 m (328 ft)
0.5 mm ² (AWG 20)	150 m (492 ft)
0.75 mm ² (AWG 19)	200 m (656 ft)

Recommended cables

It is recommended to use an ABB signal cable for standard applications. The ABB signal cable fulfills the above-mentioned cable specification and can be utilized unrestrictedly up to an ambient temperature of $T_{amb.} = 80\text{ }^{\circ}\text{C}$ (176 $^{\circ}\text{F}$).

ABB signal cable	Ordering number
5 m (16 ft)	3KQZ407123U0500
10 m (33 ft)	3KQZ407123U1000
20 m (65 ft)	3KQZ407123U2000
50 m (164 ft)	3KQZ407123U5000
100 m (328 ft)	3KQZ407123U1H00
150 m (492 ft)	3KQZ407123U1F00
200 m (656 ft)	3KQZ407123U2H00

For marine applications, an appropriate certified signal cable must be used.

ABB recommends the cable HELKAMA RFE-FRHF 2×2×0,75 QUAD 250V (HELKAMA order number 20522).

... Transmitter

Electrical connections

Electrical connection (HART protocol)

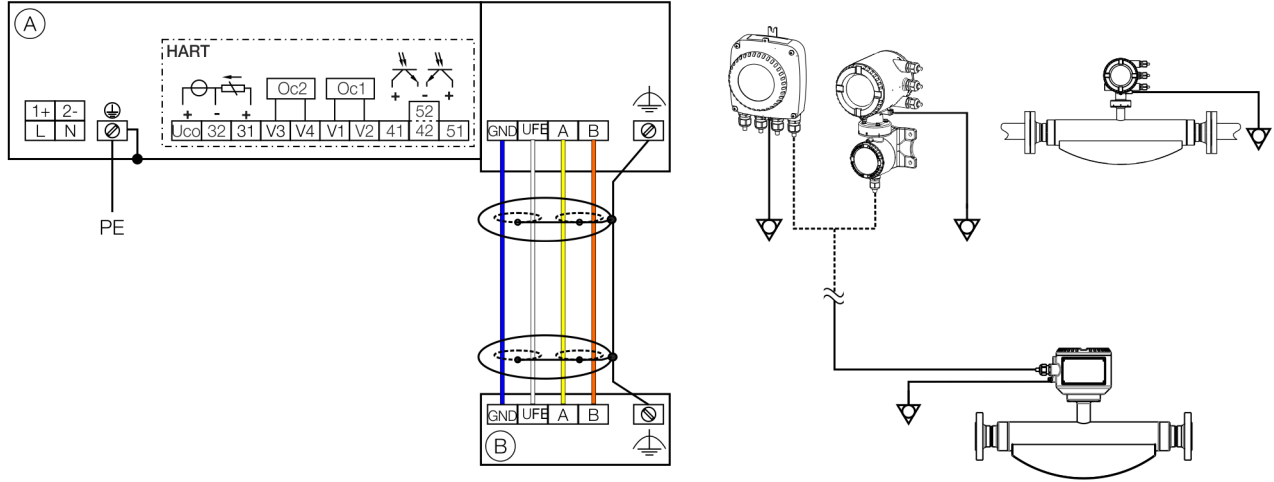

(A) Transmitter

(B) Sensor

Figure 22: Electrical connection

Connections for the power supply

AC voltage	
Terminal	Function / comments
L	Phase
N	Neutral conductor
PE / ⊕	Protective earth (PE)
▽	Potential equalization

DC voltage	
Terminal	Function / comments
1+	+
2-	-
PE / ⊕	Protective earth (PE)
▽	Potential equalization

Connections for inputs and outputs

Terminal	Function / comments
Uco / 32	Current output 4 to 20 mA- / HART® output, active or
31 / 32	Current output 4 to 20 mA- / HART® output, passive
41 / 42	Passive digital output DO1
51 / 52	Passive digital output DO2
V1 / V2	Plug-in card, slot OC1
V3 / V4	Plug-in card, slot OC2

For details, see Possible plug-in card combinations on page 81.

Connecting the signal cable

Only for remote mount design.

The sensor housing and transmitter housing must be connected to potential equalization.

Terminal	Function / comments
U _{FE}	Sensor power supply
GND	Ground
A	Data line
B	Data line
⊕	Functional earth / Shielding

Electrical data for inputs and outputs

Note

When using the device in potentially explosive atmospheres, note the additional connection data in **Use in potentially explosive atmospheres** on page 85!

Power supply L / N, 1+ / 2-

AC voltage	
Terminals	L / N
Operating voltage	100 to 240 V AC, 50 / 60 Hz
Power consumption	< 20 VA

DC voltage	
Terminals	1+ / 2-
Operating voltage	19 to 30 V DC
Power consumption	< 20 W

Current output 32 / Uco, 31 / 32 (basic device)

Can be configured for outputting mass flow, volume flow, density and temperature via on-site software.

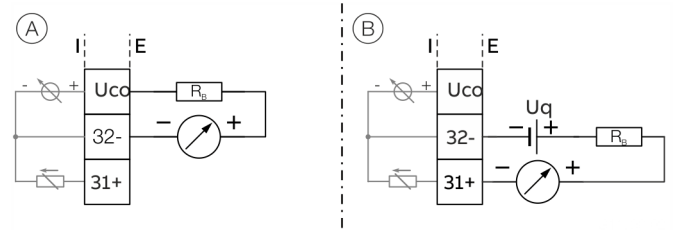

(A) Current output 31 / Uco, active (B) Current output 31 / 32, passive

Figure 23: (I = internal, E = external, RB = load)

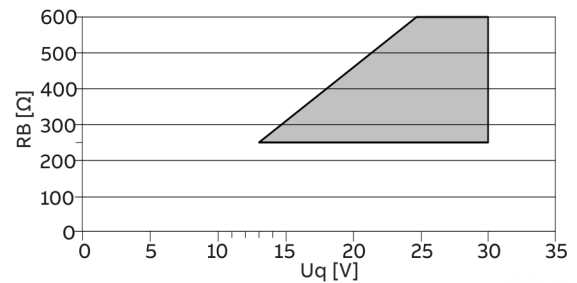

Permissible source voltage U_q for passive outputs in relation to load resistance R_B where $I_{max} = 22 \text{ mA}$. = Permissible range

Figure 24: Source voltage for passive outputs

Current output	Active	Passive
Terminals	Uco / 32	31 / 32
Output signal	4 to 20 mA or 4 to 12 to 20 mA switchable	4 to 20 mA
Load R_B	$250 \Omega \leq R_B \leq 300 \Omega$	$250 \Omega \leq R_B \leq 600 \Omega$
Source voltage U_q *	-	$13 \text{ V} \leq U_q \leq 30 \text{ V}$
Measuring error	< 0.1 % of measured value	
Resolution	0.4 μA per digit	

* The source voltage U_q is dependent of the load R_B and must be placed in an additional area.

For information on communication via the HART protocol, refer to **HART® Communication** on page 75.

... Transmitter

Current output $U_{co} / 32$ as loop power supply for digital output 41 / 42 or 51 / 52

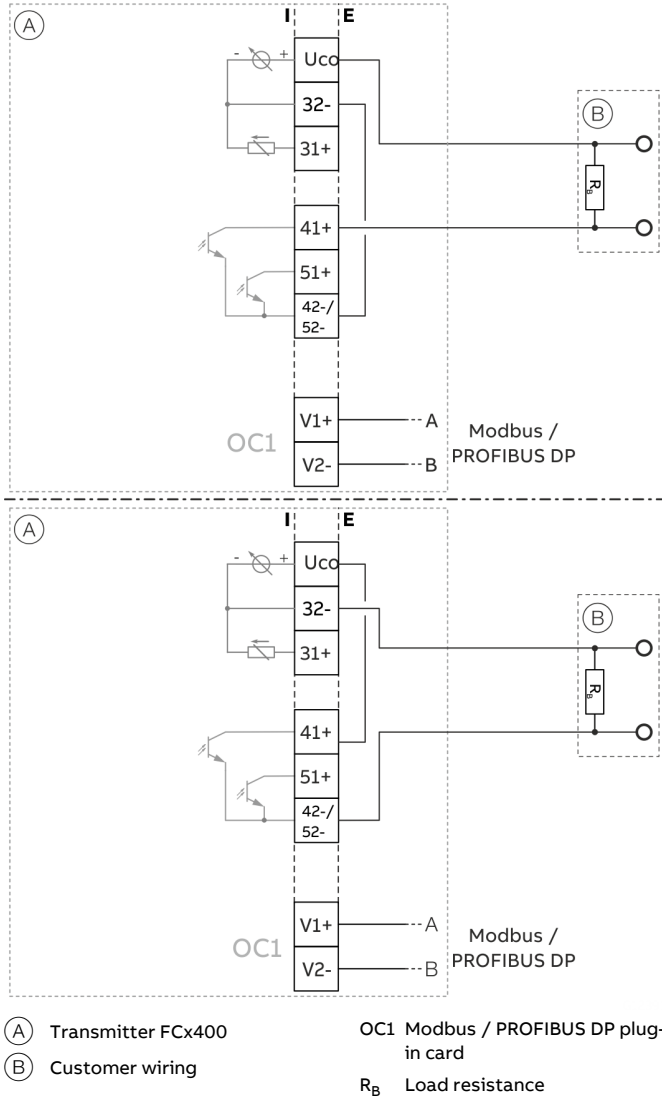

Figure 25: Current output $U_{co} / 32$ in power mode

In the case of digital communication via Modbus / PROFIBUS DP, the current output $U_{co} / 32$ can be switched to the 'Power Mode' operating mode through the software. The current output 31/32/ U_{co} is set permanently to 22.6 mA and no longer follows the selected process variable. HART communication is deactivated. As a result, the passive digital outputs 41 / 42 or 51 / 52 can also be operated as active digital outputs.

The load resistance R_B needs to be integrated by the customer outside of the transmitter housing.

Loop power supply 24 V DC operating mode

Terminals	$U_{co} / 32$
Function	For active connection of passive outputs
Output Voltage	Load dependent, see Figure 26.
Load rating I_{max}	22.6 mA, permanently short circuit-proof

Table 1: Specification current output $U_{co} / 32$ in power mode

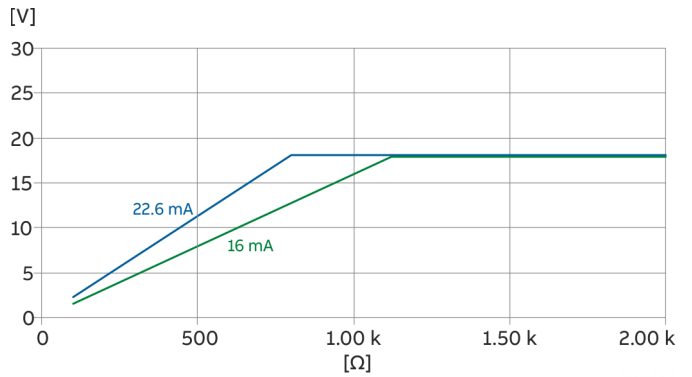
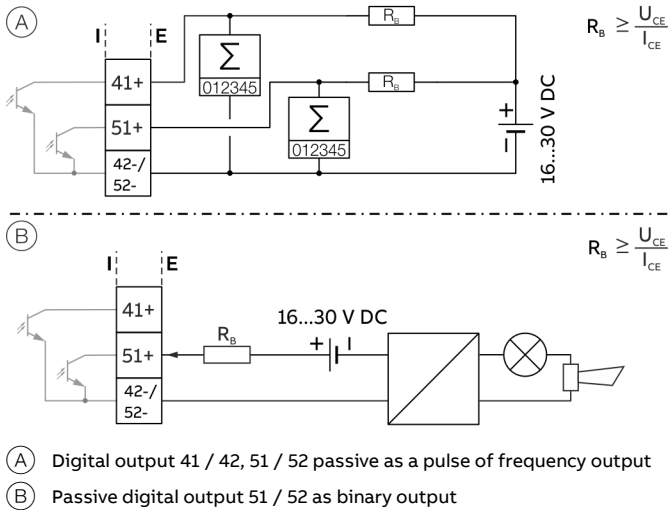

Figure 26: Output voltage dependent on load resistance

Digital output 41 / 42, 51 / 52 (basic device)
 Can be configured as pulse, frequency or binary output via on-site software.



(A) Digital output 41 / 42, 51 / 52 passive as a pulse of frequency output
 (B) Passive digital output 51 / 52 as binary output

Figure 27: (I = internal, E = external, R_B = load)

Pulse / frequency output (passive)	
Terminals	41 / 42, 51 / 52
Output 'closed'	$0 V \leq U_{CEL} \leq 3 V$ For $f < 2.5 \text{ kHz}$: $2 \text{ mA} < I_{CEL} < 30 \text{ mA}$ For $f > 2.5 \text{ kHz}$: $10 \text{ mA} < I_{CEL} < 30 \text{ mA}$
Output 'open'	$16 V \leq U_{CEH} \leq 30 V \text{ DC}$ $0 \text{ mA} \leq I_{CEH} \leq 0.2 \text{ mA}$
f_{max}	10.5 kHz
Pulse width	0.1 to 2000 ms
Binary output (passive)	
Terminals	41 / 42, 51 / 52
Output 'closed'	$0 V \leq U_{CEL} \leq 3 V$ $2 \text{ mA} \leq I_{CEL} \leq 30 \text{ mA}$
Output 'open'	$16 V \leq U_{CEH} \leq 3 V \text{ DC}$ $0 \text{ mA} \leq I_{CEH} \leq 0.2 \text{ mA}$
Switching function	Can be configured using software. See Parameter description in the operating instruction

Note

- Terminals 42 / 52 have the same potential. Digital outputs DO 41 / 42 and DO 51 / 52 are not electrically isolated from each other. If an additional electrically isolated digital output is required, a corresponding plug-in module must be used.
- If you are using a mechanical counter, we recommend setting a pulse width of $\geq 30 \text{ ms}$ and a maximum frequency of $f_{max} \leq 30 \text{ Hz}$.

Modbus® / PROFIBUS DP® interface V1 / V2 (plug-in card)
 A Modbus or PROFIBUS DP interface can be implemented by using the 'Modbus RTU, RS485 (white)' or 'PROFIBUS DP, RS485 (white)' plug-in cards.

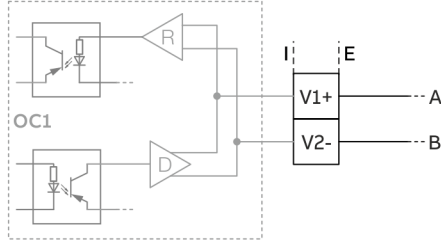

Figure 28: Plug-in card as a Modbus / PROFIBUS DP interface (I = internal, E = external)

The corresponding plug-in card can only be used in slot OC1.

For information on communication through the Modbus or PROFIBUS DP protocols, refer to chapters **Modbus® communication** on page 76 and **PROFIBUS DP® communication** on page 77.

... Transmitter

Current output V1 / V2, V3 / V4 (plug-in module)

Up to two additional plug-in modules can be implemented via the 'Passive current output (red)' option module.

Can be configured for outputting mass flow, volume flow, density and temperature via on-site software.

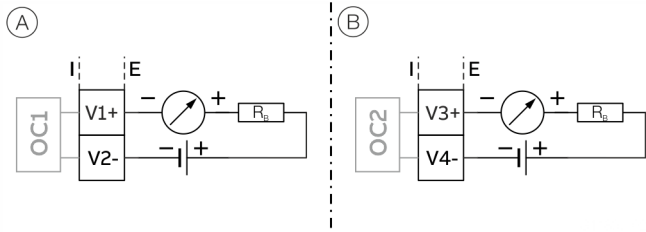

(A) Current output V1 / V2, passive (B) Current output V3 / V4, passive

Figure 29: (I = internal, E = external, R_B = load)

The plug-in module can be used in slot OC1 and OC2.

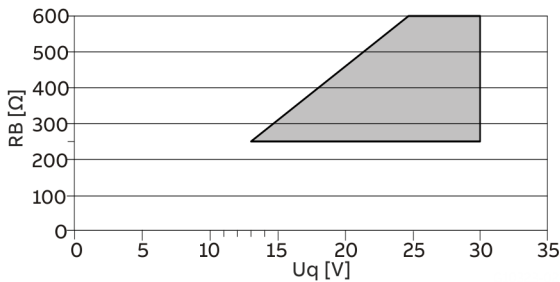

Permissible source voltage U_q for passive outputs in relation to load resistance R_B where $I_{max} = 22 \text{ mA}$. = Permissible range

Figure 30: Source voltage for passive outputs

Passive current output	
Terminals	V1 / V2, V3 / V4
Output signal	4 to 20 mA
Load R_B	$250 \Omega \leq R_B \leq 600 \Omega$
Source voltage U_q^*	$13 \text{ V} \leq U_q \leq 30 \text{ V}$
Measuring error	< 0.1 % of measured value
Resolution	0.4 μA per digit

* The source voltage U_q is dependent of the load R_B and must be placed in an additional area.

Digital output V1 / V2, V3 / V4 (plug-in module)

An additional binary output can be implemented via the 'Passive digital output (green)' plug-in module.

Can be configured as an output for flow direction signaling, alarm output etc. via on-site software.

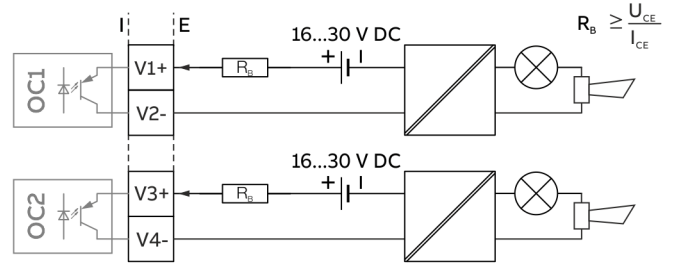

Figure 31: Plug-in card as binary output (I = internal, E = external, R_B = load)

The plug-in module can be used in slot OC1 or OC2.

Binary output (passive)	
Terminals	V1 / V2, V3 / V4
Output 'closed'	$0 \text{ V} \leq U_{CEL} \leq 3 \text{ V}$ $2 \text{ mA} < I_{CEL} < 30 \text{ mA}$
Output 'open'	$16 \text{ V} \leq U_{CEH} \leq 30 \text{ V DC}$ $0 \text{ mA} \leq I_{CEH} \leq 0.2 \text{ mA}$
Switching function	Can be configured using software. See Parameter description in the operating instruction

Digital input V1 / V2, V3 / V4 (plug-in module)

A digital input can be implemented via the 'Passive digital input (yellow)' plug-in module.

Can be configured as an input for external counter reset, external output deactivation etc. via on-site software.

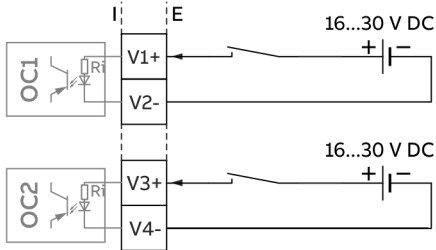

Figure 32: Plug-in card as digital input (I = internal, E = external)

The plug-in module can be used in slot OC1 or OC2.

Digital input

Terminals	V1 / V2, V3 / V4
Input 'On'	$16\text{ V} \leq U_{KL} \leq 30\text{ V}$
Input 'Off'	$0\text{ V} \leq U_{KL} \leq 3\text{ V}$
Internal resistance R_i	6.5 kΩ
Function	Can be configured using software. See Parameter description in the operating instruction

24 V DC loop power supply (plug-in module)

Use of the 'loop power supply (blue)' plug-in card allows a passive output on the transmitter to be used as an active output. See also **Connection examples** on page 73.

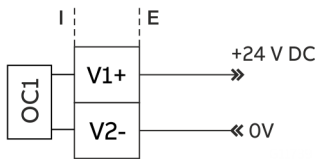

Figure 33: (I = Internal, E = External)

The plug-in module can only be used in slot OC1.

Loop power supply 24 V DC

Terminals	V1 / V2
Function	For active connection of passive outputs
Output Voltage	24 V DC at 0 mA, 17 V DC at 25 mA
Load rating I_{max}	25 mA, permanently short circuit-proof

Connection examples

Input and output functions are configured via the device software in accordance with the desired application.

See Parameter description in the operating instruction

Digital output 41 / 42, 51 / 52, V3 / V4 active

When the 'loop power supply 24 V DC (blue)' plug-in card is used, the digital outputs on the basic device and on the option modules can also be wired as active digital outputs.

Note

Each 'loop power supply (blue)' plug-in card must only power one output.

It must not be connected to two outputs (for example digital output 41 / 42 and 51 / 52)!

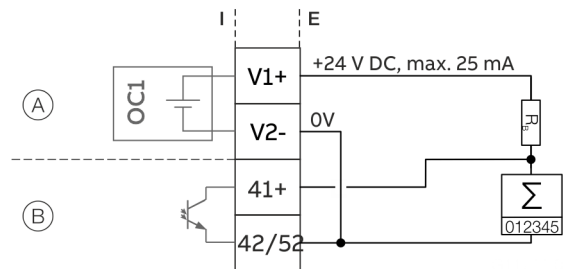

- (A) 'Loop power supply (blue)' plug-in card in slot 1
- (B) Digital output, digital output 41 / 42

Figure 34: Active digital output 41 / 42 (example)

The connection example shows usage for digital output 41 / 42; the same applies to usage for digital output 51 / 52.

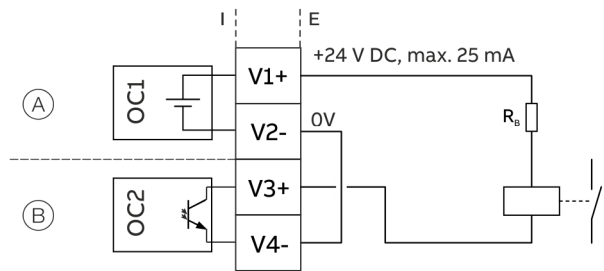

- (A) 'Loop power supply (blue)' plug-in card in slot 1
- (B) 'Digital output (green)' plug-in card in slot 2

Figure 35: Active digital output V3 / V4 (example)

... Transmitter

Digital output 41 / 42, 51 / 52 passive on distributed control system

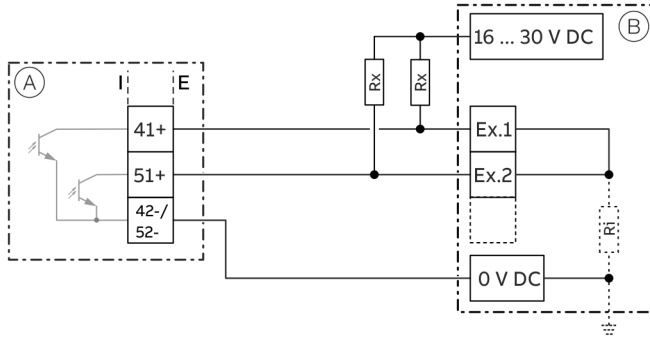

- (A) Transmitter
 - (B) Distributed control system / Memory programmable controller
- Ex. 1 Input 1
- Ex. 2 Input 2
- R_x Resistor for current limitation
- R_i Distributed control system internal resistance

Ex. 1 Input 1

Figure 36: Digital output 41 / 42 on distributed control system (example)

The R_x resistors limit the maximum current through the optoelectronic coupler of the digital outputs in the transmitter.

The maximum permissible current is 25 mA. An R_x value of $1000 \Omega / 1 W$ is recommended at a voltage level of 24 V DC. The input on the distributed control system is reduced from 24 V DC to 0 V DC (falling edge) with '1' at the digital output.

Current output V3 / V4 active

When the 'loop power supply 24 V DC, blue' plug-in card is used, the current output on the plug-in card can also be wired as the active current output.

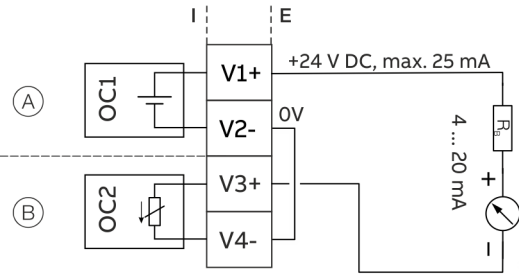

- (A) 'Loop power supply (blue)' plug-in card in slot 1
- (B) 'Passive current output (red)' plug-in card in slot 2

Figure 37: Active current output V3 / V4 (example)

Digital input V3 / V4 active

When the 'loop power supply 24 V DC, blue' plug-in card is used, the current output on the plug-in card can also be wired as the active current output.

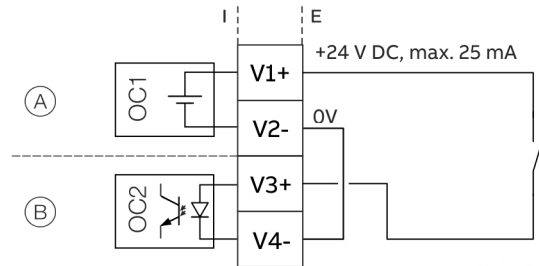

- (A) 'Loop power supply (blue)' plug-in card in slot 1
- (B) 'Passive digital input (yellow)' plug-in card in slot 2

Figure 38: Active digital output V3 / V4 (example)

Connection versions digital output 41 / 42, 51 / 52
 Depending on the wiring of digital outputs DO 41 / 42 and 51 / 52, they can be used parallel or only individually. The electrical isolation between the digital outputs also depends on the wiring.

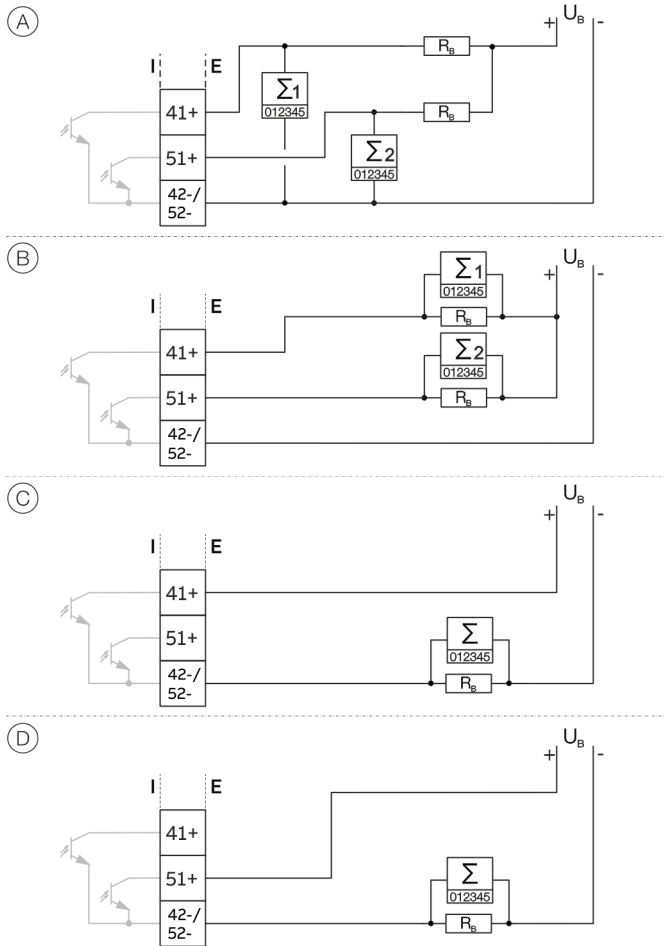

Figure 39: Connection versions digital output 41 / 42 and 51 / 52

	DO 41 / 42 and 51 / 52 can be used parallel	DO 41 / 42 and 51 / 52 electrically isolated
(A)	Yes	No
(B)	Yes	Yes
(C)	No, only DO 41 / 42 can be used	No
(D)	No, only DO 51 / 52 can be used	No

Table 2: Connection versions digital output

Digital communication

HART® Communication

Note

The HART® protocol is an unsecured protocol, as such the intended application should be assessed to ensure that these protocols are suitable before implementation.

In connection with the DTM (Device Type Manager) available to the device, communication (configuration, parameterization) can be carried out FDT 0.98 or 1.2 (DSV401 R2).

Other tool or system integrations (e.g. Emerson AMS / Siemens PCS7) on request.

The necessary DTMs and other files can be downloaded from www.abb.com/flow.

HART output	
Terminals	Active: Uco / 32 Passive: 31 / 32
Protocol	HART 7.1
Transmission	FSK modulation on current output 4 to 20 mA in accordance with the Bell 202 standard
Baud rate	1200 baud
Signal amplitude	Maximum 1.2 mAss

Factory setting of the HART process variables

HART process variable	Process value
Primary Value (PV)	Q_m – Mass flow
Secondary Value (SV)	Q_v – Volume flow rate
Tertiary Value (TV)	p – Density
Quaternary Value (QV)	T_m – Measuring medium temperature

The process values of the HART variables can be set in the device menu.

... Transmitter

Modbus® communication

Note

The Modbus® protocol is an unsecured protocol, as such the intended application should be assessed to ensure that these protocols are suitable before implementation.

Modbus is an open standard owned and administrated by an independent group of device manufacturers styled the Modbus Organization (www.modbus.org).

Using the Modbus protocol allows devices made by different manufacturers to exchange information via the same communication bus, without the need for any special interface devices to be used.

Modbus protocol

Terminals	V1 / V2
Configuration	Via the Modbus interface or via the local operating interface in connection with Asset Vision Basic (DAT200) and a corresponding Device Type Manager (DTM)
Transmission	Modbus RTU - RS485 serial connection
Baud rate	2400, 4800, 9600, 19200, 38400, 56000, 57600, 115200 baud Factory setting: 9600 baud
Parity	None, even, odd Factory setting: odd
Stop bit	One, two Factory setting: One
IEEE format	Little endian, big endian Factory setting: Little endian
Typical response time	< 100 ms
Response delay time	0 to 200 milliseconds Factory setting: 10 milliseconds

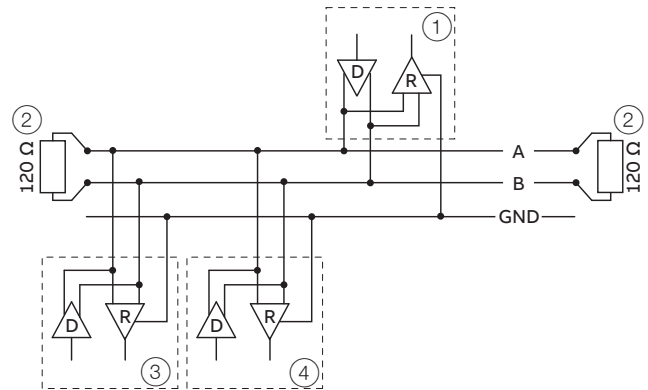

- ① Modbus master
- ② Terminating resistor
- ③ Modbus slave 1
- ④ Modbus slave n to 32

Figure 40: Communication with the Modbus protocol

Cable specification

The maximum permissible length is dependent on the baud rate, the cable (diameter, capacity and surge impedance), the number of loads in the device chain, and the network configuration (2-core or 4-core).

- At a baud rate of 9600 and with a conductor cross-section of at least 0.14 mm² (AWG 26), the maximum length is 1000 m (3280 ft).
- When using a 4-core cable as a 2-wire wiring system, the maximum length must be halved.
- The spur lines must be short, a maximum of 20 m (66 ft).
- When using a distributor with 'n' connections, each branch must have a maximum length of 40 m (131 ft) divided by 'n.'

The maximum cable length depends on the type of cable used. The following standard values apply:

- Up to 6 m (20 ft):
cable with standard shielding or twisted-pair cable.
- Up to 300 m (984 ft):
double twisted-pair cable with overall foil shielding and integrated earth cable.
- Up to 1200 m (3937 ft):
double twisted-pair cable with individual foil shielding and integrated earth cables. Example: Belden 9729 or equivalent cable.

A category 5 cable can be used for Modbus RS485 up to a maximum length of 600 m (1968 ft). For the symmetrical pairs in RS485 systems, a surge impedance of more than 100 Ω is preferred, especially at a baud rate of 19200 and above.

PROFIBUS DP® communication

Note

The PROFIBUS DP® protocol is an unsecured protocol, as such the intended application should be assessed to ensure that these protocols are suitable before implementation.

PROFIBUS DP interface	
Terminals	V1 / V2
Configuration	Via the PROFIBUS DP interface or via the local operating interface in connection with Asset Vision Basic (DAT200) and a corresponding Device Type Manager (DTM)
Transmission	In accordance with IEC 61158-2
Baud rate	9.6 kbps, 19.2 kbps, 45.45 kbps, 93.75 kbps, 187.5 kbps, 500 kbps, 1.5 Mbps The baud rate is automatically detected and does not need to be configured manually
Device profile	PA Profile 3.02
Bus address	Address range 0 to 126 Factory setting: 126

For commissioning purposes, you will need a device driver in EDD (Electronic Device Description) or DTM (Device Type Manager) format plus a GSD file.

You can download EDD, DTM and GSD from www.abb.com/flow.

The files required for operation can also be downloaded from www.profibus.com.

ABB provides three different GSD files which can be integrated in the system.

ID number	GSD file name	
0x9740	PA139740.gsd	1xAI, 1xTOT
0x9700	PA139700.gsd	1AI
0x3432	ABB_3432.gsd	6xAI, 2xTOT, 1xAO, 1xDI, 1xDO

Users decide at system integration whether to install the full range of functions or only part. Switching is made using the 'Ident Nr. Selector' parameter.

See also **Parameter description** in the operating instruction.

Limits and rules when using ABB fieldbus accessories

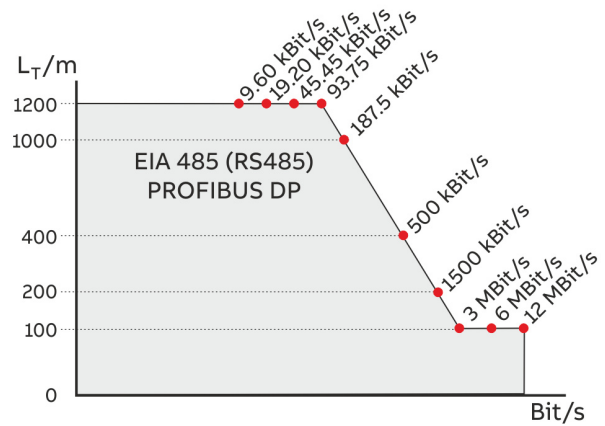

Figure 41: Bus cable length depends on the transmission rate

Pro PROFIBUS Line

(Line = Starts at DP Master and goes to last DP/PA Slave)

- Approximately 4 to 8 DP segments through the repeater (see repeater data sheets)
- Recommended DP transfer rate 500 to 1500 kBit/s
- The slowest DP node determines the transfer rate of the DP line
- Number of PROFIBUS DP and PA nodes ≤ 126 (addresses 0 to 125)

Per PROFIBUS DP segment

- Number of DP nodes ≤ 32 (Node = Devices with / without PROFIBUS address)
- Bus termination required at the beginning and end of each DP segment!
- Trunk cable length (LT) see diagram (length dependent on transfer rate)
- Cable length of at least 1 m between two DP nodes at ≥ 1500 kBit/s!
- Spur cable length (LS), at ≤ 1500 kBit/s: LS ≤ 0.25 m, at > 1500 kBit/s: LS = 0.00 m!
- At 1500 kBit/s and ABB DP cable type A:
 - Sum of all spur cable lengths (LS) ≤ 6.60 m, trunk cable length (LT) > 6.60 m, total length = LT + (Σ LS) ≤ 200 m, maximum 22 DP nodes (= 6.60 m / (0.25 m + 0.05 m spare))

... Transmitter

EtherNet/IP™ communication

Note

You will find detailed information regarding the “Ethernet” in the interface description “COM/FCB400/FCH400/E/MB”.

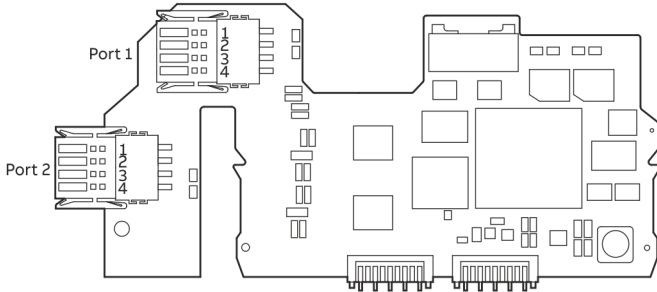

Figure 42: Ethernet communication plug-in card

One port connection without power over Ethernet

Terminal designation:

Port	Pin	Function	Color coding
1	Pin 1	RD+	White / Orange
	Pin 2	RD-	Orange
	Pin 3	TD+	White / Green
	Pin 4	TD-	Green

Standard Ethernet 10/100 BASE-T/TX (IEEE802.3) single port connection.

One port connection with power over Ethernet

Terminal designation:

Port	Pin	Function	Color coding
1	Pin 1	RD+	White / Orange
	Pin 2	RD-	Orange
	Pin 3	TD+	White / Green
	Pin 4	TD-	Green
2	Pin 1	PWR+	White / Blue
	Pin 2	PWR+	Blue
	Pin 3	PWR-	White / Brown
	Pin 4	PWR-	Brown

Standard Ethernet 10/100 BASE-T/TX (IEEE802.3) single port connection.

Two port connection without power over Ethernet

Terminal designation:

Port	Pin	Function	Color coding
1	Pin 1	RD+	White / Orange
	Pin 2	RD-	Orange
	Pin 3	TD+	White / Green
	Pin 4	TD-	Green
2	Pin 1	RD+	White / Orange
	Pin 2	RD-	Orange
	Pin 3	TD+	White / Green
	Pin 4	TD-	Green

Ethernet communication

Equipped with an Ethernet Card, CoriolisMaster provides 2 Ethernet Ports supporting a Ring, Star and Daisy Chain Network configuration.

In addition to the Ethernet Card, a plug-in Card providing ‘Power over Ethernet’ is available. This Card allows to power the 24 V DC Version of the flowmeter through Ethernet without the need for additional power supply.

EtherNet/IP™ protocol

Note

The EtherNet/IP protocol is not secure, as such. The application should be assessed before Implementation to ensure the protocol is suitable.

With implemented CoriolisMaster EtherNet/IP protocol, cyclic Communication is supported. Process Variables, Diagnostic Data and Device Status Information can be accessed cyclically.

For Device Configuration a Webserver is available providing full access to all parameter and diagnostic data.

EtherNet/IP Interface

Configuration	Through the Webserver or the local operating Interface (Display).
EtherNet / IP	5001
ProductCode	
EDS file	FCB4_FCH4_01_01.eds
Device profile	Profile 0x43, Generic Device, (keyable).
Supporte standards and protocols	Common Industrial Protocol (CIP™) Vol1, Ed 3.25 EtherNet/IP™ Adaptation of CIP™, Vol2, Ed 1.23
Cable	Cat 5

Further Ethernet communication protocols**Note**

The device supports following security modes:

Secured Protocols:

Webserver https:

Security modes

Used ports by Webserver: TCP 443

Security is based on .x509 Certificates

Protocol could be deactivated via HMI.

Unsecured protocols:

EtherNet / IP and Modbus TCP

Used ports by EtherNet/IP: TCP 44818, UDP 2222

Used ports by Modbus/TCP: TCP 502

All protocols can be enabled / disabled in the HMI

Menu.Ethernet

... Transmitter

Dimensions

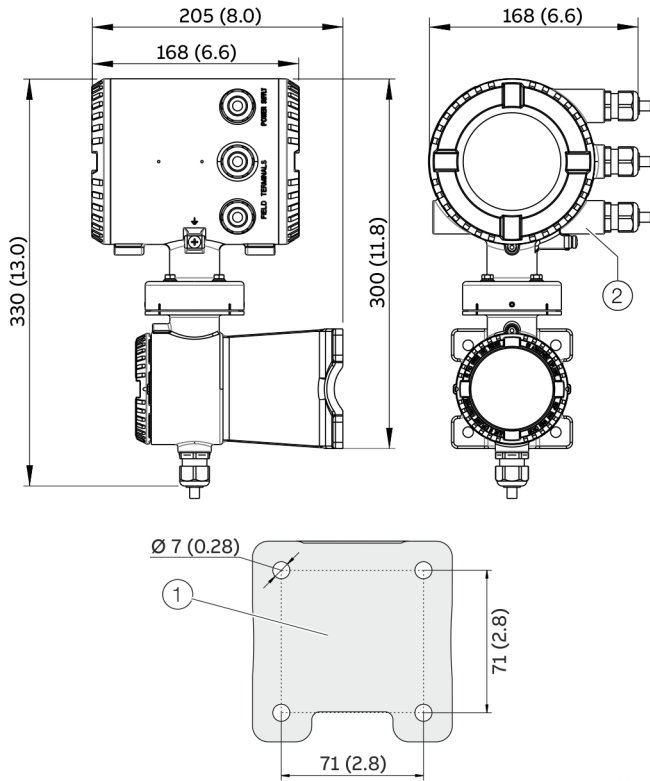

- ① Hole pattern for mounting holes
- ② Female thread (either ½ in NPT or M20 × 1.5), see model coding. In the case of a ½ in NPT, there is a plug instead of a cable gland.

Figure 43: Mounting dimensions dual-compartment housing

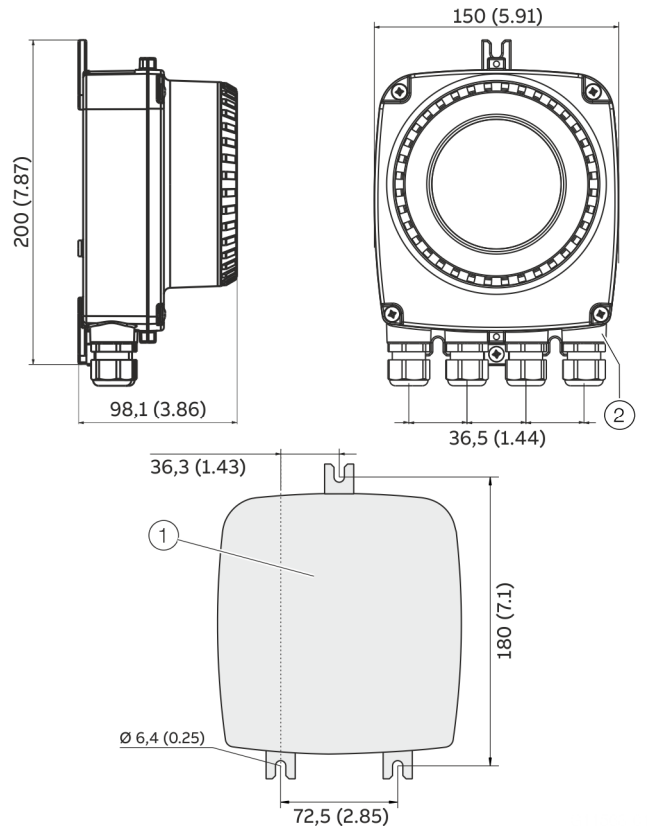

- ① Hole pattern for mounting holes
- ② Female thread (either ½ in NPT or M20 × 1.5), see model coding. In the case of a ½ in NPT, there is a plug instead of a cable gland.

Figure 44: Mounting dimensions single-compartment housing

Ordering information

Possible plug-in card combinations

The following table provides an overview of the possible plug-in card combinations that can be selected when ordering the device.

Main ordering information (outputs)	Additional ordering information		Slot OC1	Slot OC2
	Additional output	Additional output	Terminals V1 / V2	Terminals V3 / V4
	1	2		
G0	–	–	–	–
G1	–	–	Loop power supply 24 V DC (blue)	–
G2	–	–	–	Current output, 4 to 20 mA passive (red)
G3	–	–	Current output, 4 to 20 mA passive (red)	Current output, 4 to 20 mA passive (red)
G4	–	–	Loop power supply 24 V DC (blue)	Passive current output (red)
G0	DRT	–	Loop power supply 24 V DC (blue)	–
G0	DRT	DSN	Loop power supply 24 V DC (blue)	Passive digital input (yellow)
G0	DRT	DSG	Loop power supply 24 V DC (blue)	Passive digital output (green)
G0	DRT	DSA	Loop power supply 24 V DC (blue)	Current output, 4 to 20 mA passive (red)
G0	DRN	–	Passive digital input (yellow)	–
G0	DRN	DSG	Passive digital input (yellow)	Passive digital output (green)
G0	DRN	DSA	Passive digital input (yellow)	Current output, 4 to 20 mA passive (red)
G0	DRG	DSN	Passive digital output (green)	Passive digital input (yellow)
G0	DRG	DSA	Passive digital output (green)	Current output, 4 to 20 mA passive (red)
G0	DRN	DSN	Passive digital input (yellow)	Passive digital input (yellow)
G0	DRA	DSA	Current output, 4 to 20 mA passive (red)	Current output, 4 to 20 mA passive (red)
G0	DRA	DSG	Current output, 4 to 20 mA passive (red)	Passive digital output (green)
G0	DRA	DSN	Current output, 4 to 20 mA passive (red)	Passive digital input (yellow)
G0	DRM	–	Modbus RTU RS485 (white)	–
G0	DRD	–	Profibus DP, RS485 (white)	–
G0	DRM	DSN	Modbus RTU RS485 (white)	Passive digital input (yellow)
G0	DRM	DSG	Modbus RTU RS485 (white)	Passive digital output (green)
G0	DRD	DSN	Profibus DP, RS485 (white)	Passive digital input (yellow)
G0	DRD	DSG	Profibus DP, RS485 (white)	Passive digital output (green)
G0	DR6	–	Ethernet	–
G0	DR6	DS8	Ethernet (green)	Power over Ethernet (green)
G0	DR6	DSN	Ethernet (green)	Passive digital input (yellow)
G0	DR6	DSG	Ethernet (green)	Passive digital output (green)

... Transmitter

Note

For additional information on dependencies and restrictions, and for help on product selection, please refer to the Online Product Selection Assistant (PSA) at www.abb.us/flow-selector.

CoriolisMaster FCT430, FCT450 Coriolis Mass Flowmeter Transmitter

Main ordering information

CoriolisMaster FCT430 Coriolis Mass Flowmeter Transmitter	FCT430	XX	XX	XX	X
CoriolisMaster FCT450 Coriolis Mass Flowmeter Transmitter	FCT450	XX	XX	XX	X

Explosion Protection Certification

General Purpose	Y0
ATEX / IECEx (Zone 2 / 22)	A2
ATEX / IECEx (Zone 1 / 21)	A1
cFMus version Class 1 Div. 2 (Zone 2 / 21)	F2
cFMus version Class 1 Div. 1 (Zone 1 / 21)	F1
NEPSI (Zone 2 / 22)	S2
NEPSI (Zone 1 / 21)	S1

Connection Design / Transmitter Housing Type / Transmitter Housing Material / Cable Glands

Remote / Dual compartment, wall mounted / Aluminum / 4 × M20 × 1.5	R1
Remote / Dual compartment, wall mounted / Aluminum / 4 × NPT ½ in	R2
Remote / Dual compartment, wall mounted / Aluminum / 4 × M20 × 1.5 (Exd, XP)	R5
Remote / Dual compartment, wall mounted / Aluminum / 4 × NPT ½ in (Exd, XP)	R6
Remote / Single-compartment / Aluminum / 4 × M20 × 1.5	W1
Remote / Single-compartment / Aluminum / 4 × NPT ½ in	W2
Others	Z9

Outputs

Current output 1 (active or passive), digital output 1 & 2 (passive), HART, PROFIBUS DP	D1
Current output 1 (active or passive), digital output 1 & 2 (passive), HART, MODBUS	M1*
Current output 1 (active or passive), digital output 1 & 2 (passive), HART	G0
Current output 1 (active or passive), digital output 1 & 2 (passive), HART 1 Port Ethernet	E2**
Current output 1 (active or passive), digital output 1 & 2 (passive), HART 2 Port Ethernet	E3**
Current output 1 (active or passive), digital output 1 & 2 (passive), HART, 1 Port Ethernet + POE	E4**
Current output 1 (active or passive), digital output 1 & 2 (passive), 24 V DC transmitter loop power supply, HART	G1
Current output 1 (active or passive), digital output 1 & 2 (passive), current output 2 (passive), HART	G2
Current output 1 (active or passive), digital output 1 & 2 (passive), current output 2 (passive), current output 3 (passive), HART	G3
Current output 1 (active or passive), digital output 1 & 2 (passive), current output 2 (passive), 24 V DC transmitter loop power supply, HART	G4
Others	Z9

Power Supply

100 to 230 V AC	A
11 to 30 V DC	C

* The M1 version is identical to the M5 version as it may be named elsewhere

** Available with single compartment housing only, Non-Ex or Zone 2, Div. 2 only

Additional ordering information

Additional ordering information								
CoriolisMaster FCT430 Coriolis Mass Flowmeter Transmitter	XX	XX	XXX	XXX	XXX	XX	XX	XXX
CoriolisMaster FCT450 Coriolis Mass Flowmeter Transmitter	XX	XX	XXX	XXX	XXX	XX	XX	XXX
Mounting Bracket Shape / Material								
For 2 in pipe mounting / Carbon steel	B1							
Certificates								
Declaration of compliance with the order 2.1 acc. EN 10204			C4					
Inspection certificate 3.1 acc. EN 10204 for visual, dimensional and functional test			C6					
Ships Register Certifications								
DNVGL			CL1					
Bureau Veritas			CL4					
Additional Output 1								
1 × Digital input				DRN				
1 × Digital output				DRG				
1 × Analog output passive (4 to 20 mA)				DRA				
24 V DC transmitter loop power supply				DRT				
1 × MODBUS				DRM				
1 × PROFIBUS DP				DRD				
2 port Ethernet (various protocols)				DR6*				
Additional Output 2								
1 × Digital input					DSN			
1 × Digital output					DSG			
1 × Analog output passive (4 to 20 mA)					DSA			
Modul Power over Ethernet / Modbus (for Single Comp Hsg)					DS8*			
Integrated Digital Display (LCD)								
No Display, with Blind Cover						L0		
With capacitive sensorbuttons / Display (TTG) / Glass cover						L2		
Functional Safety								
SIL2 certificate								CS
Device Display Language								
German								BM1
English								BM5
French								BM4
Spanish								BM3
Italien								BM2
Portuguese								BMA
Chinese								BM6

* Available with single compartment housing only, Non-Ex or Zone 2, Div. 2 only

... Transmitter

Additional ordering information				
CoriolisMaster FCT430 Coriolis Mass Flowmeter Transmitter	XX	XX	XXX	XX
CoriolisMaster FCT450 Coriolis Mass Flowmeter Transmitter	XX	XX	XXX	XX
Documentation Language				
German	M1			
English	M5			
Language package Western Europe / Scandinavia (Languages: DA, ES, FR, IT, NL, PT, FI, SV)	MW			
Language package Eastern Europe (Languages: EL, CS, ET, LV, LT, HU, HR, PL, SK, SL, RO, BG)	ME			
Others	MZ			
Device Identification Plate				
Stainless steel plate with TAG no.			T1	
Ambient Temperature				
-40 to 70 °C (-40 to 158 °F)				TA9
Connector type				
Without				U0
1 × M 12 Plug for Ethernet 1 Port (4 signal leads)				UE*
2 × M 12 Plug for Ethernet 2 Port (4 signal leads)				UF*
1 × M 12 Plug for Ethernet 1 Port (8 signal leads)				UG*
1 × RJ45 connector with 5 m (15 ft) cable length fitted (4 signal leads)				U5*
2 × RJ45 connector with 5 m (15 ft) cable length fitted (4 signal leads)				UB*
1 × RJ45 connector with 5 m (15 ft) cable length fitted (8 signal leads)				UC*
1 × RJ45 connector with 10 m (30 ft) cable length fitted (4 signal leads)				U6*
2 × RJ45 connector with 10 m (30 ft) cable length fitted (4 signal leads)				DU*
1 × RJ45 connector with 10 m (30 ft) cable length fitted (8 signal leads)				UH*
1 × RJ45 connector with 15 m (49 ft) cable length fitted (4 signal leads)				U7*
2 × RJ45 connector with 15 m (49 ft) cable length fitted (4 signal leads)				UJ*
1 × RJ45 connector with 15 m (49 ft) cable length fitted (8 signal leads)				UK*
1 × RJ45 connector with 20 m (66 ft) cable length fitted (4 signal leads)				U8*
2 × RJ45 connector with 20 m (66 ft) cable length fitted (4 signal leads)				UN*
1 × RJ45 connector with 20 m (66 ft) cable length fitted (8 signal leads)				UP*

* Available with single compartment housing, Ethernet Card, Non-Ex or ATEX Zone 2

Use in potentially explosive atmospheres

Note

Further information on the approval of devices for use in potentially explosive atmospheres can be found in the type examination certificates or the relevant certificates at www.abb.com/flow.

Device overview

ATEX / IECEx

	Standard / No explosion protection		Zone 2, 21, 22		Zone 1, 21 (Zone 0)	
Model number	FCx4xx Y0		FCx4xx A2		FCx4xx A1	
Integral mount design						
<ul style="list-style-type: none"> • Standard • Zone 2, 21, 22 • Zone 1, 21 • Zone 0 						
Model number	FCT4xx Y0	FCx4xx Y0	FCT4xx A2	FCx4xx A2	FCT4xx A1	FCx4xx A1
Remote mount design						
Transmitter and flowmeter sensor <ul style="list-style-type: none"> • Standard • Zone 2, 21, 22 • Zone 1, 21 • Zone 0 						
Model number	FCT4xx Y0		FCT4xx A2		FCx4xx A1	
Remote mount design						
Transmitter <ul style="list-style-type: none"> • Standard • Zone 2, 21, 22 Sensor <ul style="list-style-type: none"> • Zone 1, 21 • Zone 0 						
Model number	—		FCT4xx A2		FCx4xx A1	
Remote mount design						
Transmitter <ul style="list-style-type: none"> • Zone 2, 21, 22 Sensor <ul style="list-style-type: none"> • Zone 1, 21 						

- ① Single-compartment housing
- ② Dual-compartment housing
- ③ Zone 0 within the meter tube

... Use in potentially explosive atmospheres

cFMus

	Standard / No explosion protection	Class I Div. 2 / Zone 2	Class I Div. 1 / Zone 1 (Zone 0)			
Model number	FCx4xx Y0	FCx4xx F2	FCx4xx F1			
Integral mount design						
<ul style="list-style-type: none"> Standard Div. 2 / Zone 2 Div. 1 / Zone 1 (Zone 0) 						
Model number	FCT4xx Y0	FCx4xx Y0	FCT4xx F2	FCx4xx F2	FCT4xx F1	FCx4xx F1
Remote mount design						
<ul style="list-style-type: none"> Div. 2 / Zone 2 Div. 1 / Zone 1 (Zone 0) 						
Model number	FCT4xx Y0	FCT4xx F2	FCx4xx F1			
Remote mount design						
<ul style="list-style-type: none"> Standard Div. 2 / Zone 2 Div. 1 / Zone 1 (Zone 0) 						
Model number	—	FCT4xx F2	FCx4xx F1			
Remote mount design						
<ul style="list-style-type: none"> Div. 2 / Zone 2 Div. 1 / Zone 1 (Zone 0) 						

- ① Single-compartment housing
- ② Dual-compartment housing
- ③ Zone 0 within the meter tube

... Use in potentially explosive atmospheres

ATEX / IECEx

Model number for use in Zone 2, 21	Ex marking	Certificate
FCa4c – A2Y0fghijD	II3G Ex ec IIC T6...T1 Gc	ATEX:
Integral mount design with dual-compartment housing	II2D Ex tb IIIC T80°C...Tmedium Db	FM15ATEX0014X, FM15ATEX0016X
FCa4c – A2efghijY		IECEx:
Sensor in remote mount design with dual-compartment housing		IECEx FME 15.0005X
FCT4c – A2R	II3G Ex ec IIC T6 Gc	
Transmitter in remote mount design with dual-compartment housing	II2D Ex tb IIIC T80°C Db	

Model number for use in Zone 1, 21	Ex marking	Certificate
FCa4c – A1Y0fghijDx (x = 1 to 4)	II 1/2 (1) G Ex db eb ia mb [ia Ga] IIC T6...T1 Gb	ATEX:
Integral mount design with dual-compartment housing	II 2 (1) D Ex ia tb [ia Da] IIIC T80°C Db	FM15ATEX0015X
FCa4c – A1Y0fghijDx (x = 5 to 8)	II 1/2 (1) G Ex db ia mb [ia Ga] IIB+H2 T6...T1 Gb	IECEx:
Integral mount design with dual-compartment housing (flameproof enclosure 'Ex d')	II 2 (1) D Ex ia tb [ia Da] IIIC T80°C Db	IECEx FME 15.0005X
FCa4c – A1efghijY	II 1/2 G Ex eb ia mb IIB+H2 T6...T1 Ga/Gb	
Sensor in remote mount design with dual-compartment housing	II 2 D Ex ia tb IIIC T80°C Db	
FCT4c – A1R (x = 1 to 4)	II 2 (1) G Ex db e ia mb [ia Ga] IIC T6...T1 Gb	
Transmitter in remote mount design with dual-compartment housing	II 2 (1) D Ex ia mb tb [ia Da] IIIC T80°C Db	
FCT4c – A1R (x = 5 to 8)	II 2 (1) G Ex db ia mb [ia Ga] IIB+H2 T6...T1 Gb	
Transmitter in remote mount design with dual-compartment housing (flameproof enclosure 'Ex d')	II 2 (1) D Ex ia tb [ia Da] IIIC T80°C Db	

Note

- Depending on the design, a specific marking in accordance with ATEX or IECEx applies.
- ABB reserves the right to modify the Ex-marking. Refer to the name plate for the exact marking.

cFMus

Model number for use in Division 2	Ex marking	
FCa4c – F2Y0fghijD	Certificate: FM18US0160X	Certificate: FM18CA0073X
Integral mount design with dual-compartment housing	NI: CL I,II,III Div 2, GPS ABCDEFG, T6...T1	DIP: CL II,III, Div 1, GPS EFG, T6
FCa4c – F2efghijY	CL I, ZN 2, AEx ec IIC T6...T1	ZN 21, AEx ia tb IIIC T80°C
Sensor in remote mount design with dual-compartment housing	CL I, ZN 2, Ex ec IIC T6...T1	ZN21,Ex ia tb IIIC T80°C
Design in accordance with ANSI / ISA 12.27.01 as 'Single Seal Device' or as 'Dual Seal Device' (option TE2)	See handbook for temperature class information	
FCT4c – F2R		
Transmitter in remote mount design with dual-compartment housing		
FCT4c – F2W		
Transmitter in remote mount design with single-compartment housing		

Model number for use in Division 1	Ex marking	Certificate
FCa4c – F1Y0fghijDx (x = 1 to 4)	XP-IS: CL I, Div 1, GPS ABCD,T6...T1 (USA)	cFMus: 3050239
Integral mount design with dual-compartment housing	XP-IS: CL I, Div 1, GPS BCD,T6...T1 (CAN)	
FCa4c – F1Y0fghijDx (x = 5 to 8)	DIP: CL II,III, Div 1, GPS EFG,T6	
Integral mount design with dual-compartment housing (Explosionproof 'XP').	CL I, ZN 1, AEx db ia IIB+H2 T6...T1 (USA) ZN21, AEx ia tb IIIC T80°C (USA)	
Design in accordance with ANSI / ISA 12.27.01 as 'Single Seal Device' or as 'Dual Seal Device' (option TE2)	CL I, ZN 1, Ex db ia IIB+H2 T6...T1 (CAN) ZN21, Ex ia tb IIIC T80°C (CAN) See handbook for temperature class information and installation drawing 3KXF000028G0009	
FCa4c – F1efghijY	XP-IS: CL I, Div 1, GPS BCD T6...T1 (USA)	
Sensor in remote mount design with dual-compartment housing	DIP: CL II,III, Div 1, GPS EFG,T6	
Design in accordance with ANSI / ISA 12.27.01 as 'Single Seal Device' or as 'Dual Seal Device' (option TE2)	CL I, ZN 1, AEx db ia IIB+H2 T6...T1 (USA) ZN 21, AEx ia tb IIIC T80°C (USA) CL I, ZN 1, Ex db ia IIB+H2 T6...T1 (CAN) ZN21, Ex ia tb IIIC T80°C (CAN) See handbook for temperature class information and installation drawing 3KXF000028G0009	
FCT4c – F1Rx (x = 1 to 4)	XP-IS: CL I, Div 1, GPS BCD,T6...T1 (USA) XP-IS: CL I, Div 1, GPS BCD,T6...T1 (CAN)	
Transmitter in remote mount design with dual-compartment housing	DIP: CL II,III, Div 1, GPS EFG, T6	
FCT4c – F1Rx (x = 5 to 8)	CL I, ZN 1, AEx db ia IIB+H2 T6...T1 (USA)	
Sensor in remote mount design with dual-compartment housing (Explosionproof 'XP').	ZN 21, AEx ia tb IIIC T80°C (USA) CL I, ZN 1, Ex db ia IIB+H2 T6...T1 (CAN) ZN21,Ex ia tb IIIC T80°C (CAN) See handbook for temperature class information and installation drawing 3KXF000028G0009	

Note

- Depending on the design, a specific marking in accordance with FM applies.
- ABB reserves the right to modify the Ex-marking. Refer to the name plate for the exact marking.

... Use in potentially explosive atmospheres

Temperature data

Temperature resistance for the connecting cable

The temperature at the cable entries of the device depends on the design, the measuring medium temperature T_{medium} and the ambient temperature $T_{\text{amb.}}$.

For the electric connection of the device, use only cables with sufficient temperature resistance in accordance with the following table.

Devices in integral mount design with dual-compartment housing

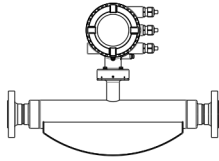

$T_{\text{amb.}}$	Temperature resistance
$\leq 50\text{ °C}$ ($\leq 122\text{ °F}$)	$\geq 70\text{ °C}$ ($\geq 158\text{ °F}$)
$\leq 60\text{ °C}$ ($\leq 140\text{ °F}$)	$\geq 80\text{ °C}$ ($\geq 176\text{ °F}$)
$\leq 70\text{ °C}$ ($\leq 158\text{ °F}$)	$\geq 90\text{ °C}$ ($\geq 194\text{ °F}$)

Devices in integral mount design with single-compartment housing

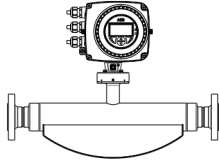

$T_{\text{amb.}}$	Temperature resistance
$\leq 50\text{ °C}$ ($\leq 122\text{ °F}$)	$\geq 75\text{ °C}$ ($\geq 167\text{ °F}$)
$\leq 60\text{ °C}$ ($\leq 140\text{ °F}$)	$\geq 85\text{ °C}$ ($\geq 185\text{ °F}$)
$\leq 70\text{ °C}$ ($\leq 158\text{ °F}$)	$\geq 95\text{ °C}$ ($\geq 203\text{ °F}$)

Sensor in remote mount design

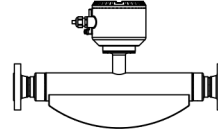

$T_{\text{amb.}}$	Temperature resistance
$\leq 50\text{ °C}$ ($\leq 122\text{ °F}$)	$\geq 105\text{ °C}$ ($\geq 221\text{ °F}$)
$\leq 60\text{ °C}$ ($\leq 140\text{ °F}$)	$\geq 110\text{ °C}$ ($\geq 230\text{ °F}$)
$\leq 70\text{ °C}$ ($\leq 158\text{ °F}$)	$\geq 120\text{ °C}$ ($\geq 248\text{ °F}$)

For sensors in remote mount design, the wires in the connection box must be additionally insulated with the enclosed silicone hoses starting from ambient temperatures of $T_{\text{amb.}} \geq 60\text{ °C}$ ($\geq 140\text{ °F}$).

Measuring medium temperature for sensors in remote mount design

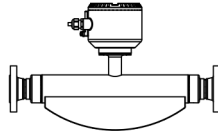

Model FCx4xx-A1..., FCx4xx-F1... in Zone 1

The table shows the maximum permissible measuring medium temperature as a function of ambient temperature and temperature class.

Ambient temperature T_{amb}	Temperature class					
	T1	T2	T3	T4	T5	T6
$\leq 30\text{ °C}$ ($\leq 86\text{ °F}$)	205 °C (400 °F)	205 °C (400 °F)	195 °C (383 °F)	130 °C (266 °F)	95 °C (203 °F)	80 °C (176 °F)
$\leq 40\text{ °C}$ ($\leq 104\text{ °F}$)	205 °C (400 °F)	205 °C (400 °F)	195 °C (383 °F)	130 °C (266 °F)	95 °C (203 °F)	80 °C (176 °F)
$\leq 50\text{ °C}$ ($\leq 122\text{ °F}$)	205 °C (400 °F)	205 °C (400 °F)	195 °C (383 °F)	130 °C (266 °F)	95 °C (203 °F)	80 °C (176 °F)
$\leq 60\text{ °C}$ ($\leq 140\text{ °F}$)	205 °C (400 °F)	205 °C (400 °F)	195 °C (383 °F)	130 °C (266 °F)	95 °C (203 °F)	80 °C (176 °F)
$\leq 70\text{ °C}$ ($\leq 158\text{ °F}$)	205 °C (400 °F)	205 °C (400 °F)	195 °C (383 °F)	130 °C (266 °F)	95 °C (203 °F)	80 °C (176 °F)

Model FCx4xx-A2... and FCx4xx-F2... in Zone 2, Division 2

The table shows the maximum permissible measuring medium temperature as a function of ambient temperature and temperature class.

Ambient temperature T_{amb}	Temperature class					
	T1	T2	T3	T4	T5	T6
$\leq 30\text{ °C}$ ($\leq 86\text{ °F}$)	205 °C (400 °F)*	205 °C (400 °F)*	195 °C (383 °F)*	130 °C (266 °F)*	95 °C (203 °F)*	80 °C (176 °F)
	195 °C (383 °F)	195 °C (383 °F)	130 °C (266 °F)	95 °C (203 °F)	80 °C (176 °F)	
$\leq 40\text{ °C}$ ($\leq 104\text{ °F}$)	205 °C (400 °F)*	205 °C (400 °F)*	195 °C (383 °F)*	130 °C (266 °F)*	95 °C (203 °F)*	—
	180 °C (356 °F)	180 °C (356 °F)	130 °C (266 °F)	95 °C (203 °F)	80 °C (176 °F)	
$\leq 50\text{ °C}$ ($\leq 122\text{ °F}$)	205 °C (400 °F)*	205 °C (400 °F)*	130 °C (266 °F)*	130 °C (266 °F)*	80 °C (176 °F)*	—
	140 °C (284 °F)	140 °C (284 °F)	130 °C (266 °F)	95 °C (203 °F)	60 °C (140 °F)	
$\leq 60\text{ °C}$ ($\leq 140\text{ °F}$)	205 °C (400 °F)*	205 °C (400 °F)*	130 °C (266 °F)*	130 °C (266 °F)*	—	—
	120 °C (248 °F)	120 °C (248 °F)	120 °C (248 °F)	95 °C (203 °F)		
$\leq 70\text{ °C}$ ($\leq 158\text{ °F}$)	180 °C (356 °F)*	180 °C (356 °F)*	130 °C (266 °F)*	130 °C (266 °F)*	—	—
	80 °C (176 °F)	80 °C (176 °F)	80 °C (176 °F)	80 °C (176 °F)		

* Only with the 'Extended tower length – TE1, TE2 or TE3' order option

... Use in potentially explosive atmospheres

Measuring medium temperature for sensors in integral mount design with dual-compartment housing

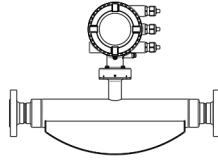

Model FCx4xx-A1... and FCx4xx-F1... in Zone 1, Division 1

The table shows the maximum permissible measuring medium temperature as a function of ambient temperature and temperature class.

Ambient temperature T_{amb}	Temperature class					
	T1	T2	T3	T4	T5	T6
$\leq 30\text{ °C}$ ($\leq 86\text{ °F}$)	205 °C (400 °F)*	205 °C (400 °F)*	195 °C (383 °F)*	130 °C (266 °F)	95 °C (203 °F)	80 °C (176 °F)
	130 °C (266 °F)	130 °C (266 °F)	130 °C (266 °F)			
$\leq 40\text{ °C}$ ($\leq 104\text{ °F}$)	205 °C (400 °F)*	205 °C (400 °F)*	195 °C (383 °F)*	130 °C (266 °F)	95 °C (203 °F)	80 °C (176 °F)
	130 °C (266 °F)	130 °C (266 °F)	130 °C (266 °F)			
$\leq 50\text{ °C}$ ($\leq 122\text{ °F}$)	205 °C (400 °F)*	205 °C (400 °F)*	195 °C (383 °F)*	130 °C (266 °F)	95 °C (203 °F)	80 °C (176 °F)
	130 °C (266 °F)	130 °C (266 °F)	130 °C (266 °F)			
$\leq 60\text{ °C}$ ($\leq 140\text{ °F}$)	205 °C (400 °F)*	205 °C (400 °F)*	195 °C (383 °F)*	130 °C (266 °F)	95 °C (203 °F)	80 °C (176 °F)
	130 °C (266 °F)	130 °C (266 °F)	130 °C (266 °F)			
$\leq 70\text{ °C}$ ($\leq 158\text{ °F}$)	205 °C (400 °F)*	205 °C (400 °F)*	195 °C (383 °F)*	130 °C (266 °F)	95 °C (203 °F)	80 °C (176 °F)
	130 °C (266 °F)	130 °C (266 °F)	130 °C (266 °F)			

* Only with the 'Extended tower length – TE1, TE2 or TE3' order option

Model FCx4xx-A2... and FCx4xx-F2... in Zone 2, Division 2

The table shows the maximum permissible measuring medium temperature as a function of ambient temperature and temperature class.

Ambient temperature T_{amb}	Temperature class					
	T1	T2	T3	T4	T5	T6
$\leq 30\text{ °C}$ ($\leq 86\text{ °F}$)	205 °C (400 °F)	205 °C (400 °F)	195 °C (383 °F)*	130 °C (266 °F)	95 °C (203 °F)	80 °C (176 °F)*
			130 °C (266 °F)			60 °C (140 °F)
$\leq 40\text{ °C}$ ($\leq 104\text{ °F}$)	205 °C (400 °F)	205 °C (400 °F)	195 °C (383 °F)*	130 °C (266 °F)	95 °C (203 °F)	—
			130 °C (266 °F)			
$\leq 50\text{ °C}$ ($\leq 122\text{ °F}$)	205 °C (400 °F)	205 °C (400 °F)	195 °C (383 °F)*	130 °C (266 °F)	—	—
			130 °C (266 °F)			
$\leq 60\text{ °C}$ ($\leq 140\text{ °F}$)	205 °C (400 °F)	205 °C (400 °F)	195 °C (383 °F)*	130 °C (266 °F)	—	—
			130 °C (266 °F)			
$\leq 70\text{ °C}$ ($\leq 158\text{ °F}$)	205 °C (400 °F)*	205 °C (400 °F)*	195 °C (383 °F)*	130 °C (266 °F)	—	—
	130 °C (266 °F)	130 °C (266 °F)	130 °C (266 °F)			

* Only with the 'Extended tower length – TE1, TE2 or TE3' order option

Measuring medium temperature for sensors in integral mount design with single-compartment housing

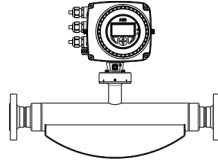

Model FCx4xx-A2... and FCx4xx-F2... in Zone 2, Division 2

The table shows the maximum permissible measuring medium temperature as a function of ambient temperature and temperature class.

Ambient temperature T_{amb}	Temperature class					
	T1	T2	T3	T4	T5	T6
$\leq 30\text{ °C}$ ($\leq 86\text{ °F}$)	205 °C (400 °F)	205 °C (400 °F)	195 °C (383 °F)	130 °C (266 °F)	95 °C (203 °F)	80 °C (176 °F)
$\leq 40\text{ °C}$ ($\leq 104\text{ °F}$)	205 °C (400 °F)	205 °C (400 °F)	195 °C (383 °F)	130 °C (266 °F)	95 °C (203 °F)	—
$\leq 50\text{ °C}$ ($\leq 122\text{ °F}$)	205 °C (400 °F)	205 °C (400 °F)	195 °C (383 °F)	130 °C (266 °F)	95 °C (203 °F)	—
$\leq 60\text{ °C}$ ($\leq 140\text{ °F}$)	205 °C (400 °F)	205 °C (400 °F)	195 °C (383 °F)	130 °C (266 °F)	—	—
$\leq 70\text{ °C}$ ($\leq 158\text{ °F}$)	205 °C (400 °F)	205 °C (400 °F)	195 °C (383 °F)	130 °C (266 °F)	—	—

* Only with the 'Extended tower length – TE1, TE2 or TE3' order option

... Use in potentially explosive atmospheres

Electrical data

Standard / No explosion protection	Zone 2, 21	Zone 1, 21 (Zone 0)
	Division 2 and Zone 2, 21	Division 2 and Zone 1, 21
ATEX:	ATEX:	ATEX:
-	II 3 G & II 2 D	II 1/2 (1) G & II 2 (1) D
IECEX:	IECEX:	II 1/2 G & II 2 D
-	Gc & Db	II 2 (1) G & II 2 (1) D
		IECEX:
		(Ga) Gb & (Da) Db
		Ga/Gb & Db
		(Ga) Gb & (Da) Db
USA:	USA:	USA:
-	NI & DIP	XP-IS & DIP
Canada:	AEx ec & AEx tb	AEx db ia & AEx ia tb
-	Canada:	Canada:
	Non-Incendive & Dust Ignition Proof	XP-IS & DIP
	Ex ec & Ex tb	Ex db ia & Ex ia tb

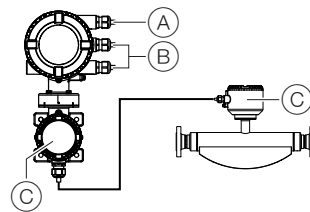
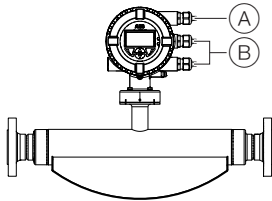

(A) Power supply

- Type of protection ATEX / IECEX: Increased safety 'Ex e'
- Type of protection USA / Canada: 'non IS'
- Maximum 250 Vrms
- Terminals: 1+, 2-, L, N, 

(B) Inputs / outputs, communication

- Type of protection ATEX / IECEX: Either increased safety 'Ex e' or intrinsically safe 'Ex ia'
- Type of protection USA / Canada: Either 'non IS' or 'intrinsically safe IS'.
- When installing in 'Ex ia' or 'IS', suitable intrinsically safe isolation amplifiers must be used for the connection.
- Terminals: 31, 32, Uco, V1, V2, V3, V4, 41, 42, 51, 52

(C) Signal cable (remote mount design only)

- Terminals: A, B, UFE, GRN
- Type of protection ATEX / IECEX: Increased safety 'Ex e'
- Type of protection USA / Canada: 'non IS'

Note

When installing in 'Ex ia' or 'IS' type of protection, the type of protection is determined by the type of electrical connection. The information in **Changing the type of protection** in the operating instruction on page 99 must be observed when changing the type of protection!

Zone 2, 21 and Division 2 – Model: FCx4xx-A2, FCx4xx-F2

Outputs on basic device	Operating values (general)		Type of protection – 'nA' / 'NI'	
	U _N	I _N	U _N	I _N
Current / HART output 31 / U_{CO}, active Terminals 31 / U _{CO}	30 V	30 mA	30 V	30 mA
Current / HART output 31 / 32, passive Terminals 31 / 32	30 V	30 mA	30 V	30 mA
Digital output 41 / 42, active* Terminals 41 / 42 and V1 / V2*	30 V	30 mA	30 V	30 mA
Digital output 41 / 42, active** Terminals 41 / 42 and U _{CO} / 32**	30 V	30 mA	30 V	30 mA
Digital output 41 / 42, passive Terminals 41 / 42	30 V	25 mA	30 V	25 mA
Digital output 51 / 52, active* Terminals 51 / 52 and V1 / V2*	30 V	30 mA	30 V	30 mA
Digital output 51 / 52, passive Terminals 51 / 52	30 V	30 mA	30 V	30 mA

All outputs are electrically isolated from each other and from the power supply.

Digital outputs 41 / 42 and 51 / 52 are not electrically isolated from each other. Terminals 42 / 52 have the same potential.

* Only in conjunction with additional '24 V DC loop power supply (blue)' plug-in card in slot OC1.

** Only in conjunction with current output U_{CO} / 32 in 'Powermode', see **Current output U_{CO} / 32 as loop power supply for digital output 41 / 42 or 51 / 52** on page 70.

Inputs and outputs with optional plug-in cards	Operating values (general)		Type of protection – 'nA' / 'NI'	
	U _N	I _N	U _N	I _N
Current output V3 / V4, active* Terminals V3 / V4 and V1 / V2*	30 V	30 mA	30 V	30 mA
Current output V1 / V2, passive**	30 V	30 mA	30 V	30 mA
Current output V3 / V4, passive** Terminals V1 / V2** or V3 / V4**				
Digital output V3 / V4, active* Terminals V3 / V4 and V1 / V2*	30 V	25 mA	30 V	25 mA
Digital output V1 / V2, passive**	30 V	30 mA	30 V	30 mA
Digital output V3 / V4, passive** Terminals V1 / V2** or V3 / V4**				
Digital input V3 / V4, active* Terminals V3 / V4 and V1 / V2	30 V	3.45 mA	30 V	3.45 mA
Digital input V1 / V2, passive*	30 V	3.45 mA	30 V	3.45 mA
Digital input V3 / V4, passive* Terminals V1 / V2** or V3 / V4**				
Modbus® / PROFIBUS DP® Terminals V1 / V2	30 V	30 mA	30 V	30 mA
Ethernet card Ethernet (various protocols) Port 1 / Port 2	57 V	417 mA	57 V	417 mA
Ethernet card in conjunction with Power over Ethernet (POE Card) Ethernet (various protocols) Port 1 / Port 2	57 V	417 mA	57 V	417 mA

* Only in conjunction with additional '24 V DC loop power supply (blue)' plug-in card in slot OC1.

** The terminal assignment depends on the model number or the slot assignments. For connection examples, see **Connection examples** on page 73.

... Use in potentially explosive atmospheres

Zone 1 ,21 und Division 1 – Model: FCx4xx-A1, FCx4xx-F1

Type of protection	'e' / 'XP'												'ia' / 'IS'	
	U _M [V]	I _M [A]	U _O [V]	U _I [V]	I _O [mA]	I _I [mA]	P _O [mW]	P _I [mW]	C _O [nF]	C _I [nF]	C _{OPA} [nF]	C _{IPA} [nF]	L _O [mH]	L _I [mH]
Outputs on basic device														
Current / HART output 31 / U_{CO}, active Terminals 31 / U _{CO}	30	0.2	30	30	115	115	815	815	10	10	5	5	0.08	0.08
Current / HART output 31 / 32, passive Terminals 31 / 32	30	0.2	—	30	—	115	—	815	—	27	—	5	0.08	0.08
Digital output 41 / 42, active* Terminals 41 / 42 and V1 / V2*	30	0.1	27.8	30	119	30	826	225	20	20	29	29	0.22	0.22
Digital output 41 / 42, active** Terminals 41 / 42 and U _{CO} / 32**	30	0.1	30	30	115	115	826	225	16	16	10	10	0.08	0.08
Digital output 41 / 42, passive Terminals 41 / 42	30	0.1	—	30	—	30	—	225	—	27	—	5	—	0.08
Digital output 51 / 52, active* Terminals 51 / 52 and V1 / V2*	30	0.1	27.8	30	119	30	826	225	20	20	29	29	0.22	0.22
Digital output 51 / 52, passive Terminals 51 / 52	30	0.1	—	30	—	30	—	225	—	27	—	5	—	0.08

All outputs are electrically isolated from each other and from the power supply.

Digital outputs 41 / 42 and 51 / 52 are not electrically isolated from each other. Terminals 42 / 52 have the same potential.

* Only in conjunction with additional '24 V DC loop power supply (blue)' plug-in card in slot OC1.

** Only in conjunction with current output U_{CO} / 32 in 'power mode', see **Current output U_{CO} / 32 as loop power supply for digital output 41 / 42 or 51 / 52** on page 70.

Type of protection	'e' / 'XP'												'ia' / 'IS'	
	U _M [V]	I _M [A]	U _O [V]	U _I [V]	I _O [mA]	I _I [mA]	P _O [mW]	P _I [mW]	C _O [nF]	C _I [nF]	C _{OPA} [nF]	C _{IPA} [nF]	L _O [mH]	L _I [mH]
Inputs and outputs with optional plug-in cards														
Current output V3 / V4, active* Terminals V3 / V4 and V1 / V2*	30	0.1	27.8	30	119	30	826	225	29	29	117	117	0.4	0.4
Current output V1 / V2, passive** Current output V3 / V4, passive** Terminals V1 / V2** or V3 / V4**	30	0.1	—	30	—	68	—	510	—	45	—	59	—	0.27
Digital output V3 / V4, active* Terminals V3 / V4 and V1 / V2*	30	0.1	27.8	30	119	68	826	225	17	17	31	31	0.4	0.4
Digital output V1 / V2, passive** Digital output V3 / V4, passive** Terminals V1 / V2** or V3 / V4**	30	0.1	—	30	—	30	—	225	—	13	—	16	—	0.27
Digital input V3 / V4, active* Terminals V3 / V4 and V1 / V2	30	0.1	27.8	30	119	3.45	826	25.8	17	17	31	31	0.4	0.4
Digital input V1 / V2, passive* Digital input V3 / V4, passive* Terminals V1 / V2** or V3 / V4**	30	0.1	—	30	—	3.45	—	25.8	—	13	—	16	—	0.27
Modbus® / PROFIBUS DP® Terminals V1 / V2	30	0.1	4.2	4.2	150	150	150	150	1.5	1.5	6	6	0.14	0.14

* Only in conjunction with additional '24 V DC loop power supply (blue)' plug-in card in slot OC1.

** The terminal assignment depends on the model number or the slot assignments. For connection examples, see **Connection examples** on page 73.

Special connection conditions

Note

The AS plug-in card (24 V DC power supply) must only be used to power the internal inputs and outputs on the device. It must not be used to power external circuits!

Note

If the protective earth (PE) is connected in the flowmeter's terminal box, you must ensure that no dangerous potential difference can arise between the protective earth (PE) and the potential equalization (PA) in areas with explosion risk.

Note

For devices with a power supply of 11 to 30 V DC, on-site external overvoltage protection must be provided. It must be ensured that the overvoltage is limited to 140 % (= 42 V DC) of the maximum operating voltage.

The output circuits are designed so that they can be connected to both intrinsically-safe and non-intrinsically-safe circuits.

- Combining intrinsically safe and non-intrinsically safe circuits is not permitted.
- On intrinsically safe circuits, potential equalization should be established along the entire length of the cable used for the signal outputs.
- The rated voltage of the non-intrinsically safe circuits is $U_M = 30 \text{ V}$.
- Intrinsic safety is preserved If the rated voltage $U_M = 30 \text{ V}$ is not up-scaled when connections are established to non-intrinsically safe external circuits.
- The information in **Changing the type of protection** in the operating instruction must be observed when changing the type of protection.

The concept of intrinsic safety allows several approved intrinsically safe devices to be interconnected without additional intrinsic safety installation checks, if the relevant installation standards are observed.

Devices connected to the relevant equipment must not be operated at over 250 V_{rms} AC or 250 V DC to ground.

Installation in accordance with ATEX or IECEx must comply with the applicable national and international standards and directives.

Installation in the USA or Canada must comply with ANSI / ISA RP 12.6, 'Installation of intrinsically safe systems for hazardous (classified) locations', the 'National Electrical Code (ANSI / NFPA 70), sections 504, 505' and the 'Canadian electrical code (C22.1-02)'.

Apparatus connected to the flowmeter must have appropriate explosion protection approval in accordance with the Entity concept.

The apparatus must have intrinsically safe circuits. The apparatus must be installed and connected in accordance with the relevant manufacturer documentation. The electrical specifications in **Electrical data** on page 94 must be observed.

Ethernet communication

DANGER

Explosion hazard due to improper installation!

Ethernet Option Cards are designed only for use in hazardous applications Zone 2 / Division 2.

The output circuits are designed so that different topologies such as daisy chain or point to point can be connected. See Installation diagram for detailed information.

- It is not permitted to combine both topologies.
- Ethernet communication is only available for installations in Zone 2/Division 2.
- The rated voltage of these non-intrinsically safe circuits are $U_M = 57 \text{ V}$.

Questionnaire

Customer:	Date:
Ms. / Mr.:	Department:
Telephone:	Fax:

Measuring medium:	Liquid content:	Gas content:
Flow rate: (min., max., operating point)	kg/h	
Density: (min., max., operating point)	kg/m ³	
Dynamic viscosity: (min., max., operating point)	mPas/cP	
Measuring medium temperature: (min., max., operating point)	°C	
Ambient temperature	°C	
Pressure: (min., max., operating point)	bar	
Rate of flow:	<input type="checkbox"/> Steady	<input type="checkbox"/> Pulsating
Batch operation:	<input type="checkbox"/> Yes	<input type="checkbox"/> No
Concentration calculation:	<input type="checkbox"/> Yes	<input type="checkbox"/> No
Transmitter design:	<input type="checkbox"/> Integral mount design	<input type="checkbox"/> Remote mount design
Explosion protection:	<input type="checkbox"/> Yes	<input type="checkbox"/> No
Power supply:	<input type="checkbox"/> 100 to 230 V AC, 50/60 Hz	<input type="checkbox"/> 11 to 30 V DC
Electrical outputs:	Communication:	
	<input type="checkbox"/> Current output I: 0/4 to 20 mA	<input type="checkbox"/> HART protocol
	<input type="checkbox"/> Current output II: 0/4 to 20 mA	
	<input type="checkbox"/> Current output III: 0/4 to 20 mA	
	<input type="checkbox"/> Pulse output, active	
	<input type="checkbox"/> Pulse output, passive	
Additional specifications:		
Pipeline diameter:mm	
Process connection:	

Trademarks

HART is a registered trademark of FieldComm Group, Austin, Texas, USA

Modbus is a registered trademark of Schneider Automation Inc.

EtherNet/IP is a trademark of ODVA Inc.

CIP (Common Industrial Protocol) is a trademark of ODVA Inc.

Hastelloy C-4 is a trademark of Haynes International

Hastelloy C-22 is a trademark of Haynes International

Sales



Service





ABB Measurement & Analytics

For your local ABB contact, visit:

www.abb.com/contacts

For more product information, visit:

www.abb.com/flow

We reserve the right to make technical changes or modify the contents of this document without prior notice. With regard to purchase orders, the agreed particulars shall prevail. ABB does not accept any responsibility whatsoever for potential errors or possible lack of information in this document.

We reserve all rights in this document and in the subject matter and illustrations contained therein. Any reproduction, disclosure to third parties or utilization of its contents – in whole or in parts – is forbidden without prior written consent of ABB.